

University of Alberta

The Construction of Diverse Nitrogen-Containing Heterocycles *via* the
Reaction of Amines or Azides with Metallocarbenes

by

Tina Marie Bott

A thesis submitted to the Faculty of Graduate Studies and Research
in partial fulfillment of the requirements for the degree of

Doctor of Philosophy

Department of Chemistry

©Tina Marie Bott
Fall 2011
Edmonton, Alberta

Permission is hereby granted to the University of Alberta Libraries to reproduce single copies of this thesis and to lend or sell such copies for private, scholarly or scientific research purposes only. Where the thesis is converted to, or otherwise made available in digital form, the University of Alberta will advise potential users of the thesis of these terms.

The author reserves all other publication and other rights in association with the copyright in the thesis and, except as herein before provided, neither the thesis nor any substantial portion thereof may be printed or otherwise reproduced in any material form whatsoever without the author's prior written permission.

*To my parents and my husband
for their many years of
encouragement and support*

Abstract

A fundamental goal in organic chemistry is the development of new and innovative ways of transforming simple building blocks into complex structures. The formation of ylides from the reaction of metallocarbenes with heteroatoms, such as the nitrogen of an amine or azide, is an example of a versatile methodology that is capable of undergoing divergent transformations into a wide variety of nitrogen-containing heterocycles.

Azetidines are a class of small, strained amines, which display properties of their smaller and larger ring counterparts, aziridines or pyrrolidines, depending on the nature of their substitution pattern and their chemical environment. Chapter 1 will highlight the recent advances in the synthesis and application of these molecules in the recent literature.

In chapter 2, we demonstrate the ability of azetidines to undergo ring expansion to pyrrolidines *via* the Stevens rearrangement of ammonium ylides. In this methodology, azetidines behave in a manner distinct from equivalent systems lacking ring strain. This investigation allowed for the construction of a range of differently functionalized pyrrolidines in a one step procedure from readily available azetidines and diazocarbonyl compounds.

An extension of this successful azetidine ring expansion chemistry, to provide access to more complex heterocyclic ring systems, is described in chapter 3. The goal of this project was to determine the functionality required on the azetidine ring to direct the Stevens rearrangement in an intramolecular fashion.

The use of carbonyl and silyl groups as a means of directing the transformation was investigated. These groups were chosen for their ability to be easily removed or transformed after the ring expansion process in order to access a broader range of compounds during later applications.

In chapter 4, we describe a new methodology for the formation of *C*-acylimines through the reaction of organic azides with *in situ* generated metallocarbenes. Using aryl-tethered diazo-azide substrates allowed for the production of highly reactive *C*-acylimines, which in the presence of carbon nucleophiles could be subsequently trapped to form highly conjugated indolone derivatives. In contrast, when an alkyl tether was used, we observed the formation of an isolable *C*-acylimine, which displayed intriguing umpolung chemistry when treated with organozinc reagents.

Acknowledgements

There are many people who I need to thank for providing encouragement and support over the last five years. First and foremost would be my boss, Dr. Frederick West. Thank you for your guidance and reassurance throughout this entire process. I have really enjoyed working with you and I am quite certain that my experience in the West group will be fondly remembered for the rest of my life.

To all past and present the members of the West group.....without you, life in the lab would just be plain old work. Over the years we have been on many adventures, both inside and outside of the lab, and the memories I have are going to last a lifetime.

To Tina, Craig, Jef, Sara and Hayley: I don't know if you know this, but you're kind of a big deal! I don't think I could have imagined landing myself in with a better group of people. I have found a great friend in each and every one of you, which has made my time here worth every minute. I'll see you all in Disneyland – 2020!

To Ryan and Owen: Not your average hipsters or beer snobs! It has been great working with the both of you the last few years and I hope that when you make the trek out to Vancouver to visit family you'll stop by. Owen, I really appreciate you letting me overstay my welcome. I assume it was because you felt guilty for beating Brock at basketball so many times.

Christine – I'm leaving you my pink cowboy hat – USE IT!

To my parents, David and Debbie Bott: Thank you for always believing in me. There is nothing I want more in this world than to make you proud so I hope this fits the bill!

To my husband Brock: How do I even begin? You are the most amazing person I know. You have been there for me every step of the way and have put up with a lot! You've been a sounding board, an editor, a bearer of tissues and

possibly, just a few times, my designated driver. I can't even begin to express how much your love and support has gotten me through the last five years. I will try my best to reciprocate over the next two years. I love you babe!

Table of Contents

Chapter 1

1.1. Introduction.....	1
1.2. Azetidine-Containing Natural Products	3
1.3. Synthesis of Azetidines.....	5
1.3.1. Ring Closure by C-N Bond Formation	5
1.3.2. Ring Closure by C-C Bond Formation	12
1.3.3. Reduction of β -Lactams and Cycloaddition Reactions.....	16
1.4. Synthetic Application of Azetidines	21
1.4.1. Ring-Opening to Acyclic Amines.....	22
1.4.2. Ring Expansion to Pyrrolidines and Other 5-Membered Heterocycles.....	31
1.4.3. Ring Expansion to Six-Membered Heterocycles	41
1.4.4. Ring Expansion to Medium-Sized Heterocycles	42
1.4.5. Application of Azetidines in Catalysis	47
1.5. References.....	51

Chapter 2

2.1. Introduction.....	59
2.2. Synthetic Efforts to the Pyrrolidine Core.....	61
2.2.1. Intramolecular Aminopalladation	62
2.2.2. [3+2]-Cycloadditions	63
2.2.3. Ring Expansion of Azetidines	64
2.3. Background.....	66
2.3.1. Methods for Ylide Formation	67
2.3.2. The Desilylation Method for Ylide Formation	68
2.3.3. The Use of Carbenes in Ylide Generation	68
2.4. Trends in Migratory Selectivity in the Stevens [1,2]-Shift.....	70

2.5.	The Intermolecular Ring Expansion of Azetidines to Pyrrolidines	73
2.5.1.	Synthesis of Substrates	73
2.5.2.	Optimization of the Reaction	75
2.5.3.	Discussion	78
2.5.4.	Conclusions	83
2.5.5.	Future Directions	85
2.6.	Experimental	86
2.6.1.	General Information	86
2.6.2.	Characterization	87
2.7.	References	97

Chapter 3

3.1.	Introduction	102
3.2.	Studies Toward the Ring Expansion of Spirocyclic Azetidinium Ylides	104
3.2.1.	Studies toward the use of β -Lactams in the Stevens [1,2]-shift	107
3.2.2.	Studies Toward Asymmetric α -Lithiation of Azetidines.....	111
3.3.	Conclusion	119
3.4.	Future Directions	120
3.5.	Experimental	121
3.5.1.	General Information	121
3.5.2.	Characterization	122
3.6.	References	128

Chapter 4

4.1.	Introduction	130
4.1.1.	Reaction of Metallocarbenes with Amines	132
4.1.2.	Reaction of Metallocarbenes with Imines.....	134
4.1.3.	Reaction of Metallocarbenes with Amides	135

4.1.4. Reaction of Metallocarbenes with Nitriles	138
4.2. Reaction of Metallocarbenes with Azides	138
4.3. Results and Discussion	140
4.4. Conclusions	152
4.5. Future Directions	152
4.6. Experimental	154
4.6.1. General Information	154
4.6.2. Characterization	155
4.7. References	166

Appendices

Appendix I: Selected NMR Spectra from Chapter 2	170
Appendix II: Selected NMR Spectra from Chapter 3	211
Appendix III: Selected NMR Spectra from Chapter 4.....	229

List of Tables

Chapter 1

Table 1.1: Geometric parameters of azetidine.	2
Table 1.2: Substituent effects on the formation of either azetidines or pyrrolidines.	11

Chapter 2

Table 2.1: Substituent migration in [1,2]-shift of acyclic ylides.	71
Table 2.2: Effect of aryl-substituents on [1,2]-shift.	72
Table 2.3: Survey of catalysts for the formation of 43.	76
Table 2.4: Examination of substrate scope using standard reaction conditions. ..	77
Table 2.5: Improvement in yields with microwave heating.	78

Chapter 3

Table 3.1: Survey of condition employed for the attempted α -lithiation/silylation of N-Boc azetidine.	112
Table 3.2: Conditions used in an attempt to remove the thiopivaloyl protecting group.	115
Table 3.3: Conditions for the attempted hydrolysis on thioimidate salt 60.	118

Chapter 4

Table 4.1: Nucleophilic trapping of reactive C-acylimines with various C- nucleophiles.	144
Table 4.2: Optimization of the microwave conditions for azide displacement. ..	150

List of Figures

Chapter 1

Figure 1.1: Small nitrogen heterocycles.	1
Figure 1.2: ¹ H NMR chemical shifts of aziridine, azetidine and pyrrolidine.	3
Figure 1.3: Effect of substituents on the observed geminal coupling of azetidines.....	3
Figure 1.4: Azetidine-containing natural products.	4
Figure 1.5: Comparison of steric interactions in <i>cis</i> and <i>trans</i> -2,4-disubstituted azetidines.....	46

Chapter 2

Figure 2.1: Selection of pyrrolidine natural products.	59
Figure 2.2: Proline-derived organocatalysts.	60
Figure 2.3: Possible mechanistic pathways of aminopallidation.	62
Figure 2.4: Catalytic cycle for the formation of ammonium ylides from metallocarbenes.....	70

Chapter 3

Figure 3.1: Natural products containing our target 5,7- or 5,8-ring system.	104
--	-----

Chapter 4

Figure 4.1: Commonly employed catalysts in ammonium ylide formation.	132
Figure 4.2: Natural products containing an indolone framework.	154

List of Schemes

Chapter 1

Scheme 1.1: Retrosynthetic pathways to azetidines.	6
Scheme 1.2: Synthesis of azetidines via double S _N 2 displacement of halides.....	7
Scheme 1.3: Expedient synthesis of azetidines using microwave heating.	7
Scheme 1.4: Cyclization of chiral 1,3-aminoalcohols for azetidine-2-carboxylic acid synthesis.	8
Scheme 1.5: Synthesis of 2,4- <i>trans</i> -disubstituted azetidines from aldimines and acetophenone.....	8
Scheme 1.6: Azetidines from Baylis-Hillman adducts.	9
Scheme 1.7: SmI ₂ -mediated cyclization of α -aminoaldehydes.	9
Scheme 1.8: Activation of allylamines for the synthesis of azetidines.....	10
Scheme 1.9: Azetidine and pyrrolidine formation via selenium activation of homoallylic amines.	10
Scheme 1.10: N-Boc protected azetidines from hydrozirconation of allylamines.	12
Scheme 1.11: Base-promoted synthesis of <i>N</i> -Boc-2-azetidine carboxylic acid. ..	12
Scheme 1.12: Synthesis of 2,3-disubstituted azetidines through carbon-carbon bond formation.....	13
Scheme 1.13: Synthesis of azetidines from (<i>S</i>)-phenylalanol.	13
Scheme 1.14: Synthesis of azetidines (1 <i>R</i> ,2 <i>S</i>)-ephedrine and (1 <i>S</i> ,2 <i>S</i>)-pseudoephedrine.	14
Scheme 1.15: Derivatives accessible from 2-cyano-azetidines.	15
Scheme 1.16: The application of Michael addition towards azetidine synthesis.	15
Scheme 1.17: Azetidines from radical cyclization α -methylamino ketones.	16
Scheme 1.18: The Staudinger reaction for β -lactam synthesis.....	16
Scheme 1.19: Mechanism of the Staudinger reaction.....	17
Scheme 1.20: β -lactams from the [2+2]-cycloaddition of chlorosulfonylisocyanate and olefins.....	18

Scheme 1.21: Synthesis of azetidines by cyclization of aldimines with allyl silanes.....	18
Scheme 1.22: Azetidine formation under Baylis-Hillman conditions.....	19
Scheme 1.23: Asymmetric synthesis of azetidines using a cincona alkaloid catalyst.....	19
Scheme 1.24: Mechanism of the "abnormal" Baylis-Hillman reaction.....	20
Scheme 1.25: Azetidine formation using an iodine-mediated oxidative cyclization.....	20
Scheme 1.26: Possible mechanisms for oxidative cyclization.....	21
Scheme 1.27: Lewis-acid catalyzed opening of azetidines with allylsilanes.....	22
Scheme 1.28: Ring opening of azetidines with aryl borates.....	23
Scheme 1.29: Formation of acylsilanes via acid-mediated ring opening of azetidines.....	23
Scheme 1.30: Ring opening of azetidines with methylchloroformate.....	24
Scheme 1.31: Effect of relative stereochemistry on product formation.....	24
Scheme 1.32: Ring opening of azetidinium species with various nucleophiles..	25
Scheme 1.33: Ring opening of azetidines to obtain amides with α -quaternary centers.....	25
Scheme 1.34: Rationale for observed regioselectivity of ring opening.....	26
Scheme 1.35: Effect of relative stereochemistry on reaction yields.....	26
Scheme 1.36: Conformational preferences for nucleophilic attack by azide.....	27
Scheme 1.37: Ring opening of azetidines with carbon nucleophiles.....	28
Scheme 1.38: Unexpected epoxide formation.....	28
Scheme 1.39: Mechanism of epoxide formation.....	29
Scheme 1.40: Test reaction with pyrrolidine substrate.....	29
Scheme 1.41: Cyclopropanation of enones with azetidinium salts.....	30
Scheme 1.42: Proposed mechanism of cyclopropanation.....	30
Scheme 1.43: Cyclopropanation with pyrrolidinium salts.....	30
Scheme 1.44: Ring expansion of <i>N</i> - <i>tert</i> -butyl-2-methanesulfonyloxymethylazetidine with Ph_3PBr_2	31
Scheme 1.45: Ring expansion of azetidines with chloroalanes.....	32

Scheme 1.46: Ring expansion of selenylated azetidines.	32
Scheme 1.47: Ring expansion of α -chloromethyl azetidines with retention of configuration.	33
Scheme 1.48: Ring expansion of α -hydroxymethyl azetidines through activation with mesyl chloride.	33
Scheme 1.49: Mechanism of ring expansion.	34
Scheme 1.50: Observation of diastereomeric products with secondary α -hydroxymethyl azetidines.	35
Scheme 1.51: Ring opening of α -chloromethyl azetidines with external nucleophiles.	35
Scheme 1.52: Nucleophilic ring opening with DAST.	35
Scheme 1.53: Lewis acid activated ring expansion of α -aminomethyl azetidines.	36
Scheme 1.54: Synthesis of (-)-absoulone <i>via</i> an azetidine ring-opening strategy.	37
Scheme 1.55: Ring expansion of azetidines <i>via</i> Stevens [1,2]-shift.	38
Scheme 1.56: Synthesis of the natural products (\pm)-turneforcidine and (\pm)-platynecine.	39
Scheme 1.57: One-step ring expansion of azetidines to pyrrolidines by the Stevens [1,2]-shift.	39
Scheme 1.58: Ring expansion of azetidines to 1,3-oxazolidines.	40
Scheme 1.59: Ring expansion of azetidines to oxazolidinones.	40
Scheme 1.60: Failed ring opening of 4-substitued azetidines.	41
Scheme 1.61: Ring expansion of azetidines to piperidines.	41
Scheme 1.62: [4+2]-cycloadducts by opening of azetidines with nitriles or aldehydes.	42
Scheme 1.63: Formation of 2,3,6,7-tetrahydroazepines or pyrrolidines from azetidinium ylides.	43
Scheme 1.64: Explanation for observed reactivity of <i>cis</i> and <i>trans</i> 2-alkenylazetidines.	43
Scheme 1.65: Mechanism of eight-membered ring formation.	44
Scheme 1.66: Competitive formation of acyclic products in highly	

functionalized azetidines.....	44
Scheme 1.67: Rhodium-catalyzed ring expansion of azetidines to azocinone derivatives.....	45
Scheme 1.68: Ring expansion of azetidines to 1,4-oxazepanes and 1,5-oxazocines.....	45
Scheme 1.69: Formation of hydrooxazocenes from azetidines and propargyl alcohols.....	46
Scheme 1.70: Asymmetric reduction of aldehydes and ketones with oxaborolidines.....	47
Scheme 1.71: Asymmetric alkylation of aldehydes with diethyl zinc and azetidine-based catalysts.....	48
Scheme 1.72: Use of azetidines as ligands on rhodium for enantioselective cyclopropanations.....	48
Scheme 1.73: Use of L-azetidine-2-carboxylic acid for the asymmetric α -amidation of ketones.....	49
Scheme 1.74: Asymmetric Michael additions with azetidine-based catalysts.....	50
Scheme 1.75: Proposed transition state for Michael addition with diethylmalonate.....	50
Scheme 1.76: Proposed transition state for Michael addition with acetoacetone.....	51

Chapter 2

Scheme 2.1: Generation of pyrrolidines via [3+2]-cycloaddition with olefins.....	63
Scheme 2.2: Generation of pyrrolidines via [3+2]-cycloaddition with imines.....	64
Scheme 2.3: Intramolecular ring-expansion of azetidines to pyrrolidines.....	64
Scheme 2.4: Intermolecular ring-expansion of azetidines to pyrrolidines.....	65
Scheme 2.5: Synthesis of turneforcidine and platynecine via intramolecular Stevens [1,2]-shift.....	65
Scheme 2.6: First reported example of the Stevens rearrangement.....	66
Scheme 2.7: Radical pair mechanism.....	66

Scheme 2.8: First example of ammonium ylide formation using carbenes.....	69
Scheme 2.9: Migration of non-conjugatively stabilized substituents.	72
Scheme 2.10: Synthesis of N-alkyl-2-carbomethoxyazetidines.	74
Scheme 2.11: Synthesis of 2,2-dimethyl-N-benzyl azetidine.....	74
Scheme 2.12: Synthesis of N-benzylazetidine.....	75
Scheme 2.13: Synthesis of diazocarbonyl compounds.	75
Scheme 2.14: Mechanistic rational for the formation of diastereomers.	80
Scheme 2.15: Possible [2,3]-rearrangement pathway of N-allyl azetidine 78b....	80
Scheme 2.16: Possible α' , β -fragmentation pathway of N-pentyl azetidine 78a ...	81
Scheme 2.17: Formation of dehydrogenated pyrrolidine products.....	81
Scheme 2.18: Interesting results with azetidines 78c and 78d.....	82
Scheme 2.19: Debenzoylative oxidation of pyrrolidine 88k.	82
Scheme 2.20: Example of benzyl [1,2]-shift by Burger and coworkers.....	83
Scheme 2.21: Unexpected Hofmann elimination of 78c under quaternization conditions.....	84
Scheme 2.22: Possible $\alpha'\beta$ -fragmentation pathway of ylide derived from 78c....	84
Scheme 2.23: Application of azetidine ring expansion to the formation of bicyclic systems.	85
Scheme 2.24: Investigating the effect of diazo stability on ring expansion vs. benzyl migration.	86

Chapter 3

Scheme 3.1: Ring expansion of azetidines to pyrrolidines <i>via</i> the Stevens [1,2]-shift.	101
Scheme 3.2: Synthesis of aza-heterocycles <i>via</i> an intramolecular Stevens [1,2]-shift.	102
Scheme 3.3: Synthesis of the pyrrolizidine alkaloids turneforcidine and platynecine.	102
Scheme 3.4: Ring expansion of a diazo-tethered azetidine <i>via</i> a spirocyclic azetidinium ylide.....	104

Scheme 3.5: Reactivity of <i>N</i> -benzylazetidine with differently stabilized diazocarbonyl compounds.	104
Scheme 3.6: Synthesis of azocane 19.	104
Scheme 3.7: Mechanism for the generation of azocane 19.	105
Scheme 3.8: Proposed [1,2]-acyl shift of β -lactams.	106
Scheme 3.9: Synthesis of β -lactam substrates.	106
Scheme 3.10: Attempted Stevens [1,2]-shift of β -lactams with <i>in situ</i> derived metallocarbenes.....	107
Scheme 3.11: Equilibrium between carbonyl and ammonium ylides.....	107
Scheme 3.12: Precedent for preferential ammonium ylide formation.....	108
Scheme 3.13: Possible reaction pathways after generation of an ammonium ylide.....	109
Scheme 3.14: Synthesis of dihydroxyquinolizidines <i>via</i> a silyl-directed [1,2]-shift.	109
Scheme 3.15: Asymmetric α -lithiation/electrophilic substitution of <i>N</i> -Boc pyrrolidine.....	110
Scheme 3.16: Synthesis of <i>N</i> -Boc azetidine.	110
Scheme 3.17: Successful α -lithiation/electrophilic substitution of <i>N</i> -thiopivaloylazetidine.....	112
Scheme 3.18: Synthesis of α -silylated azetidine derivative 51.	113
Scheme 3.19: Removal of thiopivaloyl protecting group from 53.	113
Scheme 3.20: Successful replacement of the thiopivaloyl group on 51 with a Boc group.....	114
Scheme 3.21: Synthesis of the α -DMPS-azetidine derivative 57.....	115
Scheme 3.22: Replacement of the thiopivaloyl group on 57 with a Boc group.	115
Scheme 3.23: Synthesis of a stable thioimidate salt from azetidine 57.	116
Scheme 3.24: Oxidation of thiopivaloyl azetidine 57 to pivaloyl azetidine 62..	117
Scheme 3.25: Naphthalene-catalyzed lithiation protocol for the deprotection of amides.	118
Scheme 3.26: Proposed strategy to access pyrrolidines 67.....	118

Scheme 3.27: Inter- and intramolecular silyl-directed ring expansion of azetidinium ylides.	119
Scheme 3.28: Optimization of enantioselective α -lithiation/silylation protocol.	120

Chapter 4

Scheme 4.1: Pathways of metallocarbene reactivity with nitrogen nucleophiles.	129
Scheme 4.2: Mechanism of ylide generation <i>via</i> metallocarbenes.	130
Scheme 4.3: Mechanism of the Stevens Rearrangement.	131
Scheme 4.4: Reactions of metallocarbene derived azomethine ylides.	134
Scheme 4.5: Intramolecular ylide formation with amides.	135
Scheme 4.6: Change in ylide reactivity upon the addition of DMAP.	135
Scheme 4.7: Equilibrium between ammonium and carbonyl ylides.	136
Scheme 4.8: Insight into ylide equilibrium in the presence of DMAP.	136
Scheme 4.9: Reactions of nitrile ylides.	137
Scheme 4.10: Early example of azides reacting with metallocarbenes.	138
Scheme 4.11: First example of Rh-catalyzed reaction of an azide with a metallocarbenes.	138
Scheme 4.12: Use of azide/metallocarbene chemistry for derivatization of diaminocyclopentanol.	139
Scheme 4.13: Proposed route to cyclic C-acylimines.	139
Scheme 4.14: Attempted synthesis of a simple azide-tethered diazocarbonyl compound.	140
Scheme 4.15: Synthesis of a stable diazo-azide test substrate.	140
Scheme 4.16: Initial test reaction with diazo-azide 70.	141
Scheme 4.17: Indolone derivatives by <i>in situ</i> trapping of the C-acylimine with a silyl ketene acetal.	142
Scheme 4.18: Mechanism for the formation of the tricyclic indolone derivative 77.	144

Scheme 4.19: Stepwise oxidation of indolone derivative 75.....	144
Scheme 4.20: Synthesis of distabilized aryl-tethered diazo-azide substrate.....	145
Scheme 4.21: Synthesis of indolones possessing quaternary centers.....	146
Scheme 4.22: Retrosynthetic approach to an alkyl-tethered diazo-azide substrate.....	146
Scheme 4.23: Synthesis of an unexpected α -amino diazocarbonyl compound..	147
Scheme 4.24: Retrosynthetic analysis of an acyclic, distabilized diazo-azide substrate.....	147
Scheme 4.25: Synthesis of an acyclic diazo-azide substrate.....	148
Scheme 4.26: Formation of a stable C-acylimine product.....	149
Scheme 4.27: Addition of organometallic reagents to C-acylimine 106.....	150
Scheme 4.28: Reactivity of α -aminoesters with organometallic reagents.....	150
Scheme 4.29: Potential for homologation of the alky-tethered diazo-azide substrates.....	151
Scheme 4.30: Exploration into the umpolung reactivity of alky-tethered diazo- azides.....	152
Scheme 4.31: Intermolecular reaction of azides with diazocarbonyl compounds.....	152

Chapter 1

Synthesis and Applications of Azetidines: An Increasingly Important Class of Small Nitrogen Heterocycles

1.1. Introduction

Azetidine (**2**) is the parent molecule of a class of small-ring, nitrogen-containing heterocycles, which have been gaining attention for their versatility in many areas of chemistry.¹ The increased exploration into the chemistry of these molecules stems from the interesting behaviour they exhibit in synthetic and biochemical settings as well as the development of new methods to synthesize them. It has been found that these compounds can display properties of their smaller or larger-ring counterparts, aziridines (**1**) or pyrrolidines (**3**), depending on the nature of their substitution pattern and their chemical environment.

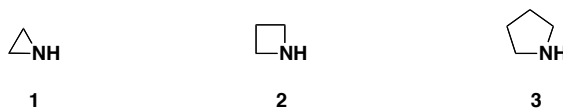
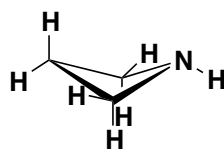

Figure 1.1: Small nitrogen heterocycles.

The physical properties of many different azetidines have been reported in the literature. In general, azetidines adopt a relatively rigid, puckered conformation bent 10-20 degrees out of planarity depending on their substitution pattern.² The electron diffraction data of azetidine has been used to calculate the bond lengths and bond angles present in the molecule, which are shown in Table 1.1. The lone pair on nitrogen is favoured to be in the pseudo-axial position; however, with an inversion barrier of ca. 10 kcal/mol, inversion at room temperature does occur.³

The ring strain energy associated with the azetidine ring has been experimentally determined to be 25.2 kcal/mol.⁴ This number is very close to that observed for aziridine at 26.7 kcal/mol. In contrast, the ring strain energies for pyrrolidine and piperidine are 5.8 and 0 kcal/mol respectively. Interestingly, although strained, azetidines are more similar to pyrrolidines than aziridines when it comes to several of their physical properties. For example, the pK_a of the conjugate acid of azetidine (11.29)² is much closer to that of pyrrolidine (11.31)² than to aziridine (7.98).⁵ In terms of basicity, this means that azetidine can behave like a typical secondary amine in most reactions.



	Bond Length (Å)
N-C	1.48
C-C	1.55
C-H	1.11
N-H	1.02
	Bond Angle (degrees)
CNC	92
CCC	87
CCN	86
HCH	110

Table 1.1: Geometric parameters of azetidine.²

A comparison of the ^1H NMR chemical shift data of these three heterocycles also shows a much closer resemblance of azetidine (**2**) to pyrrolidine (**3**) rather than aziridine (**1**), as the bond angles are not deformed enough to induce an upfield chemical shift as seen in aziridine (Figure 1.2).⁶ On examination of the coupling constants (J), however, the addition of substituents on either carbon or

nitrogen can significantly affect the observed J -values between geminal protons, as commonly observed with aziridines, whereas this effect is not as prominent in pyrrolidines.

Some examples of the effect changing the substituent on nitrogen (**4**, **5** and **6**) as well as the addition of a substituent on C-4 (**7** and **8**) can have on the observed $J_{2,2}$ -values are shown in Figure 1.3.^{7, 1a} This is most likely due to changes in the puckering angle of the ring, which affects the hybridization on the carbon atoms, and can be explained by application of the geminal Karplus curve.⁶ These data are especially notable because they give insight into the conformational changes that can occur in these molecules when different substituents are present. This will be an important factor later on in this review when there are significant changes in the reactivity of one azetidines vs. another based on differences in their substitution pattern around the ring.

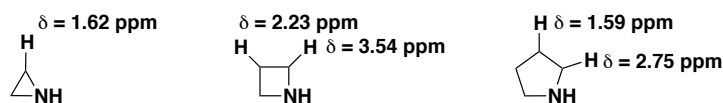

Figure 1.2: ^1H NMR chemical shifts of aziridine, azetidine and pyrrolidine.

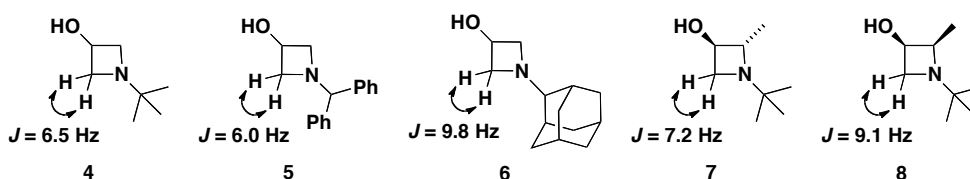

Figure 1.3: Effect of substituents on the observed geminal coupling of azetidines.

1.2. Azetidines-Containing Natural Products

Although azetidines itself has not been found in nature there are several analogues that have been isolated. L-Azetidine-2-carboxylic acid (**9**), the first azetidines natural product to be discovered, was isolated from *Convallaria majalis* (lily of the valley) in 1955.⁸ Research into the role of this molecule suggests it is a

proline receptor antagonist affecting the structure of proteins in the natural predators of the plant.⁹ It has subsequently been found in several other plants and is the parent molecule for a number of other natural products found in both plants and animals (Figure 1.4).^{1b}

Mugineic acid (**10**), 2'-deoxymugineic acid (**11**) and nicotianamine (**12**) are structurally related phytosidophores which are produced in plants to aid in the uptake of iron for chlorophyll biosynthesis. Due to this interesting biological activity, there have been a number of synthetic efforts towards their production.¹⁰ Penaresidin A and B (**13** and **14**) have also been the targets of several syntheses as they have been found to exhibit biological activity in the activation of ATPase in actomyosin.¹¹ Several members of the polyoxin family of compounds (**15**) have proven valuable as fungicides in an agricultural setting.¹² The most recently reported natural product containing the azetidine moiety, calydaphninone (**16**), was isolated from the leaves and twigs of *Daphniphyllum calycillum* in 2007.¹³ This molecule, containing a 4-azatricyclo[5.2.2.0]undecane core, represents one of the most complex azetidine-containing natural products seen to date.

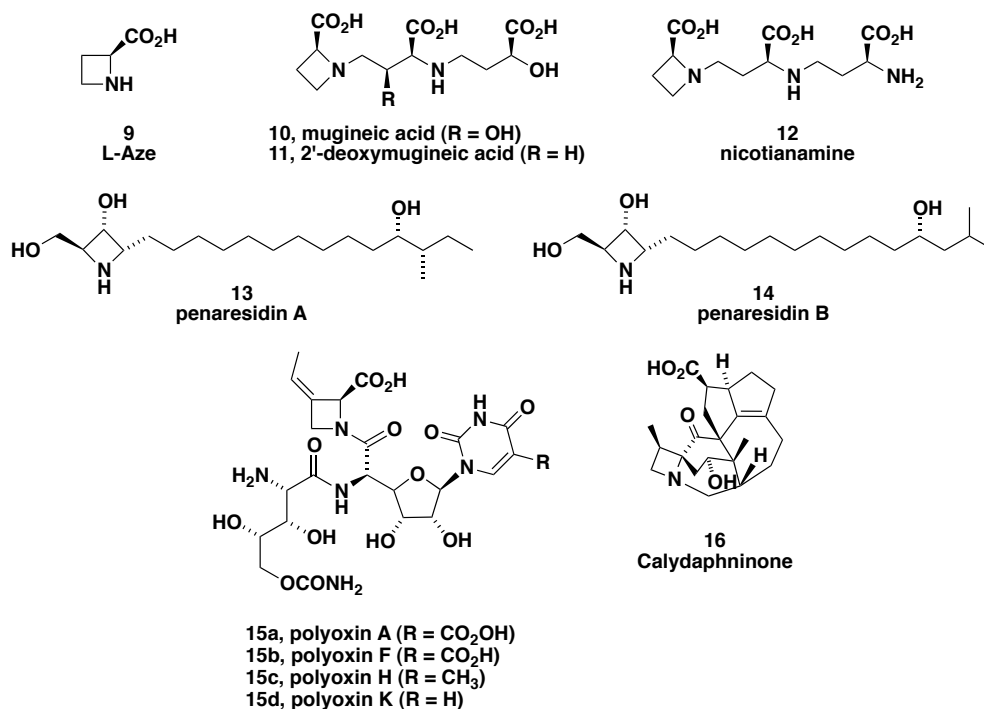

Figure 1.4: Azetidine-containing natural products.

The natural products in Figure 1.4 all possess at least one stereogenic center on the azetidine ring. The presence of up to three contiguous stereogenic centers, seen in **13** and **14**, as well as an α -quaternary center, seen in **16**, indicates the challenges that can arise when attempting to prepare complex azetidine-containing targets as single compounds. The need to synthesize the azetidine core with complete control over the stereochemistry is important, as it is well known that the biological activity of a molecule is often directly related to the relative and absolute configuration of its substituents.

1.3. Synthesis of Azetidines

Increased activity in the area of azetidine synthesis over the last few decades has been driven by growth in their application in both synthetic and medicinal chemistry. The azetidine ring system, however, is one of the most challenging ring systems to form of the common azaheterocycles.^{1c} The difficulty in its formation lies in the increased ring strain of the target molecule once it is formed. This increase in strain energy makes the ring closure process energetically unfavourable. Although there are multiple reported methods for the synthesis of azetidines in the literature, only a few are generally applicable to form a large array of products and have the ability to place substituents at different positions around the ring.^{1a-c} This section will focus on summarizing the most versatile methods for azetidine synthesis with a highlight of some promising new methodology.

1.3.1. Ring Closure by C-N Bond Formation

The displacement of a leaving group by nitrogen is the oldest and most commonly used route for the formation of the azetidine ring system. This method, which allows for the incorporation of multiple substituents on various positions around the ring, has taken on several variations over the past few

decades. Scheme 1.1 shows some general methods for azetidine formation that are present in the literature. These methods include, but are not limited to: addition of amines (**18**) to 1,3-dielectrophiles (**19**), ring closure of γ -haloamines or activated γ -aminoalcohols (**20**), reductive cyclization of γ -haloimines (**21**) or α -amino aldehydes/ketones (**22**), activation of allylamines (**23**) and ring-opening of epoxides or aziridines (**24**).

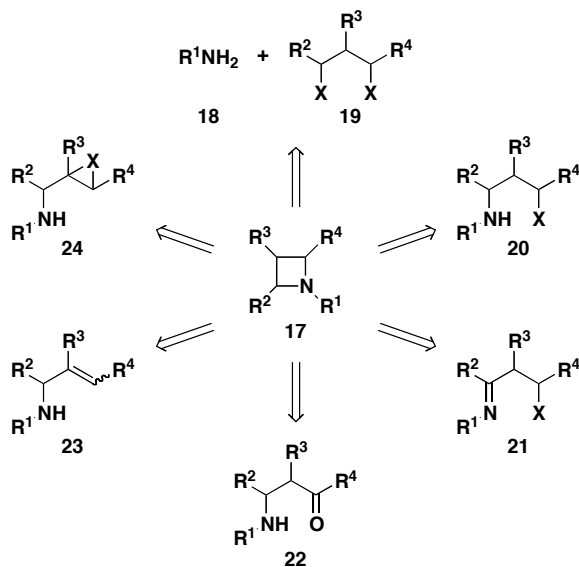

Scheme 1.1: Retrosynthetic pathways to azetidines.

The double S_N2 cyclization of 1,3-electrophiles with primary amines is well established in the literature. A classic example is the synthesis of azetidine-2-carboxylic esters **26** from the reaction of primary amines with 2,4-dibromobutyrate **25** (Scheme 1.2).¹⁴ This approach generally allows for a number of different alkyl or aryl substituents on both R^1 and R^2 to accommodate for subsequent functionalization. A wide variety of other leaving groups have also been utilized, including chlorides, iodides, triflates, mesylates, tosylates and sulfonic esters depending on the nature of the reaction media. Unfortunately, a drawback of this methodology is the tendency for polymerization and/or elimination side reactions to occur during prolonged heating, which contributes to low yields.

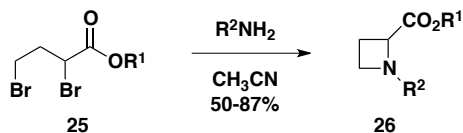

Scheme 1.2: Synthesis of azetidines via double S_N2 displacement of halides.

The advancement of microwave technology has been fortuitous for the preparation of azetidines by this type of displacement. Burkett and coworkers have reported the synthesis of a variety of different *N*-substituted azetidines in good yields by reaction of primary amines with the cyclic sulfate of propanediol (**27**) (Scheme 1.3).¹⁵ Initial formation of 3-(ammonio)propyl sulfates (**28**) followed by 15 minutes of microwave irradiation in basic aqueous media gave rise to analytically pure azetidines (**29**) in good yields.

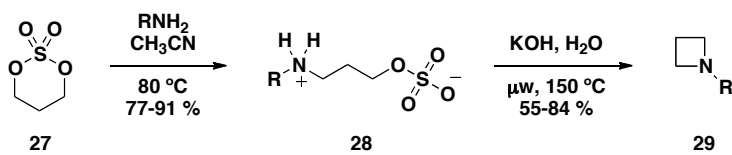

Scheme 1.3: Expedient synthesis of azetidines using microwave heating.

The ability to access enantiopure 1,3-aminoalcohols has been key to the successful construction of enantiopure azetidines. In 2005, the Enders group reported the synthesis of *N*-tosyl-2,3-disubstituted azetidines (**34**) with excellent diastereo- and enantioselectivities from the cyclization of 1,3-aminoalcohols derived from SAMP/RAMP-hydrazone methodology (Scheme 1.4).¹⁶ Most notably, the authors were subsequently able to transform the 2-phenyl substituent on **34** to the acid (**35**) by oxidation with ruthenium tetroxide followed by deprotection of the amine. The small amounts of acyclic products (**36**) obtained were most likely the result of ring opening followed by oxidation at the benzylic position.

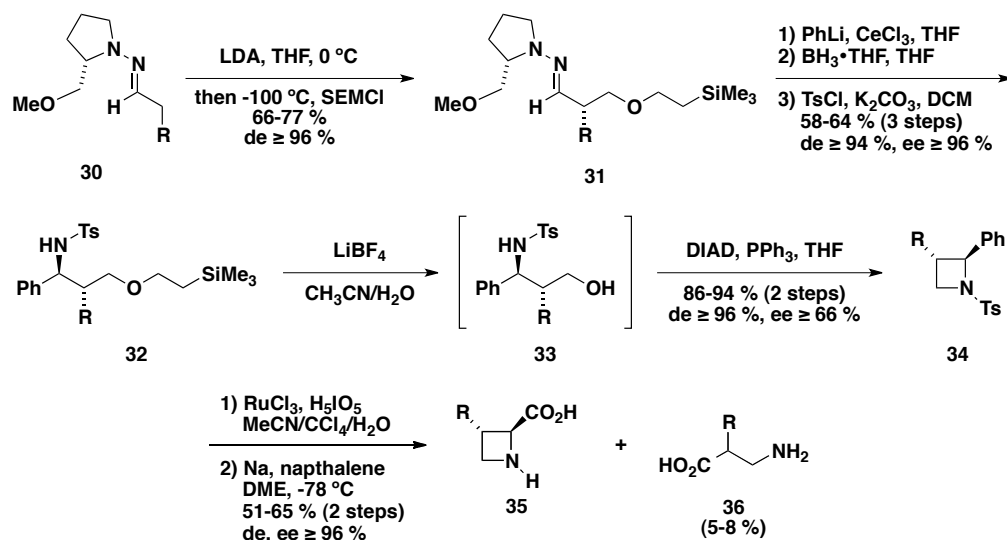

Scheme 1.4: Cyclization of chiral 1,3-aminoalcohols for azetidine-2-carboxylic acid synthesis.

On a similar note, Das and coworkers have recently reported the synthesis of *N*-tosyl-2,4-disubstituted azetidines (**41**) from *N*-tosylaldimines (**37**) and acetophenone (**38**, Scheme 1.5).¹⁷ The authors treated a mixture of **37** and **38** with BF₃·OEt₂ in dichloromethane to generate β-amino ketone **39**, which was subsequently reduced to a mixture of *syn* and *anti* 1,3-aminoalcohols (**40**) in the presence of sodium borohydride. After separation, the *anti*-isomer of **40** was refluxed with potassium hydroxide and tosyl chloride to give the *cis*-azetidine product **41** in 57-64 % yield over three steps with only one purification step.

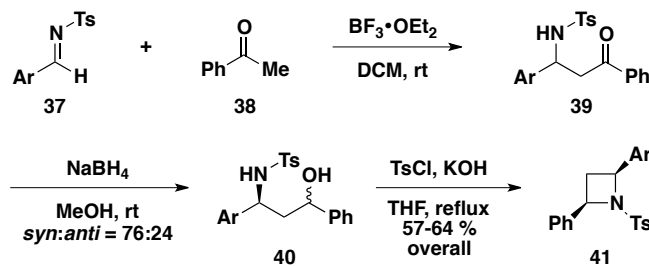

Scheme 1.5: Synthesis of 2,4-*trans*-disubstituted azetidines from aldimines and acetophenone.

The Yadav group has reported a clever way to access Ts activated 1,3-aminoalcohols derivatives *in situ* for the synthesis of azetidine-3-carbonitriles **44** and azetidine-3-carboxylates **45** by the addition of phosphoramidates (**42**) to

Baylis-Hillman adducts (**43**, Scheme 1.6).¹⁸ This one pot protocol involves treatment of diethyl *N*-arylphosphoramidates (**42**) with sodium hydride followed by addition of Baylis-Hillman adduct **43** to form aza-Michael intermediate **I**. Intramolecular attack of the alkoxide ion on phosphorus generates intermediate **II**, which opens to **III** before displacement of the phosphate ester with the amide nitrogen. The resulting azetidine (**44/45**) is isolated in 94-96 % yield exclusively as the *trans* stereoisomer.

The conversion of α -amino aldehydes **46** to aminoiodohydrins **47** with Sm/CH₂I₂ followed by treatment with silver tetrafluoroborate has resulted in the formation of stable enantiopure 3-hydroxy-azetidinium salts **48** in good yields which could be almost quantitatively monodebenzylated to the azetidine (**49**) by hydrogenolysis (Scheme 1.7).¹⁹

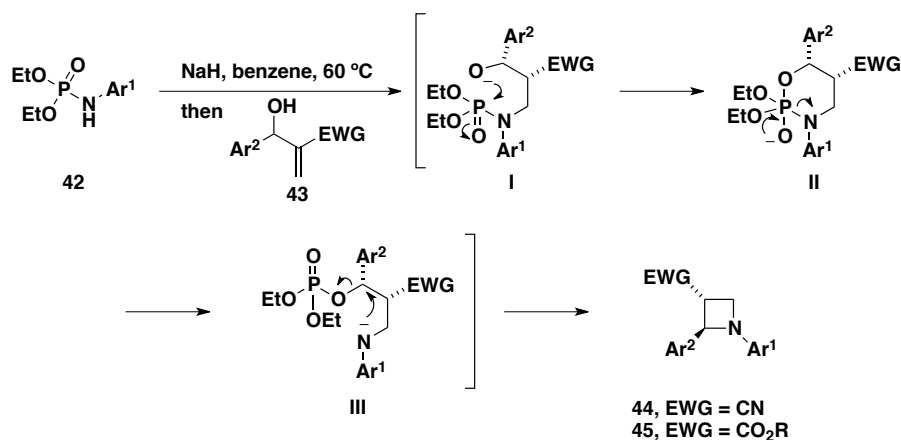

Scheme 1.6: Azetidines from Baylis-Hillman adducts.

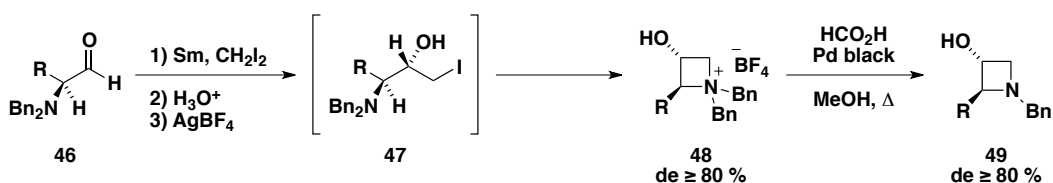

Scheme 1.7: SmI₂-mediated cyclization of α -aminoaldehydes.

The activation of allylic and homoallylic amines for the regioselective synthesis of azetidines has been accomplished with several alkene-activating agents. The most commonly employed reagents are electrophilic halogen sources, which give rise to halonium ion intermediates that are displaced by the pendent amine to form the desired azetidine. In an example of this approach by the Rousseau group (Scheme 1.8), activation of allylic amines (**50**) with an electrophilic bromine source, results in the construction of azetidines (**51**) in moderate to good yields by a 4-*endo* cyclization.²⁰

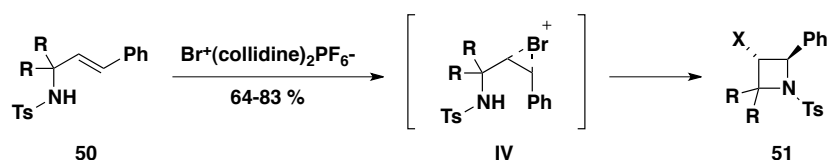

Scheme 1.8: Activation of allylamines for the synthesis of azetidines.

The Outurquin group has described the activation of homoallylic amines (**52**) with phenylselenenyl halides resulting in the generation of both azetidines (**53**) and pyrrolidines (**54**).²¹ The ratio of the observed products was initially found to be dependent on the number of equivalents of the activating agent used as well as the substitution alpha to the nitrogen (Scheme 1.9).

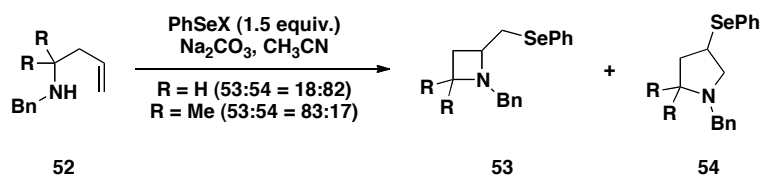

Scheme 1.9: Azetidine and pyrrolidine formation via selenium activation of homoallylic amines.

More recently, however, the group has been able to fine-tune this methodology to allow for preferential azetidine formation without being constrained by substitution at the α -position. The authors can instead change the substitution on the alkene portion of allylamine **55** to preferentially form either

the azetidine (**56**) or the pyrrolidine (**57**) without having to rely exclusively on the Thorpe-Ingold effect to induce cyclization to the desired product (Table 1.2).

In 2011, Szymonias and coworkers published an interesting synthesis of *N*-Boc-protected azetidines through a diastereoselective hydrozirconation of chiral allylic amines.²² Treatment of enantiomerically pure allyl amines **58** with Schwartz' reagent allowed for *syn*-hydrozirconation of the double bond (**V**), which was then converted to iodide **59**. The addition of NaHMDS promoted cyclization to the *cis*-2,3-disubstituted azetidine **60** in moderate to good yields (Scheme 1.10). This reaction, which is tolerant of a wide variety of substituent types (alkyl, aryl, CH₂OR) and possesses an easily removable nitrogen protecting group, allows for simple access to synthetically useful, diastereomerically enriched azetidines in a short reaction sequence.

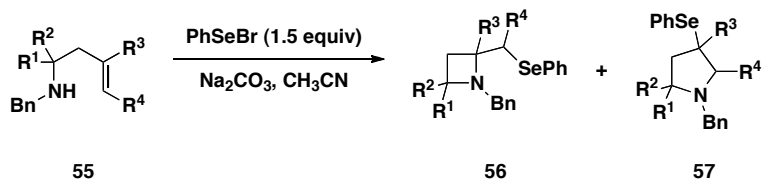

Entry	R ¹	R ²	R ³	R ⁴	Yield 56 (%)	Yield 57 (%)
1	H	H	H	Ph	-	55
2	Et	H	H	Ph	-	73
3	<i>i</i> Pr	H	H	Ph	-	80
4	Ph	H	H	Ph	-	72
5	Me	Me	H	Ph	-	88
6	H	H	Me	H	35	-
7	Me	H	Me	H	45	-
8	Et	H	Me	H	58	-
9	tBu	H	Me	H	68	-
10	Ph	H	Me	H	67	-
11	Me	Me	Me	H	72	-

Table 1.2: Substituent effects on the formation of either azetidines or pyrrolidines.

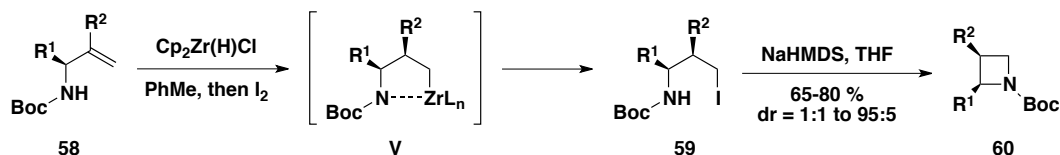

Scheme 1.10: N-Boc protected azetidines from hydrozirconation of allylamines.

1.3.2. Ring Closure by C-C Bond Formation

There are significantly fewer examples of azetidine synthesis by a carbon-carbon bond formation in the literature compared to the carbon-nitrogen bond forming approaches discussed above. One advantage of this disconnection is the ability to place groups on nitrogen that are not typically amenable to nucleophilic displacement reactions. An example of this was reported by Luche and coworkers in 1994 (Scheme 1.11).²³ Starting from glyoxylic acid (**61**), a one-pot reductive amination/protection sequence gave *N*-(ω -chloroethyl)-Boc-glycine (**62**). Cyclization of **62** in the presence of LDA led to *N*-Boc-protected azetidine-2-carboxylic acid **63**.

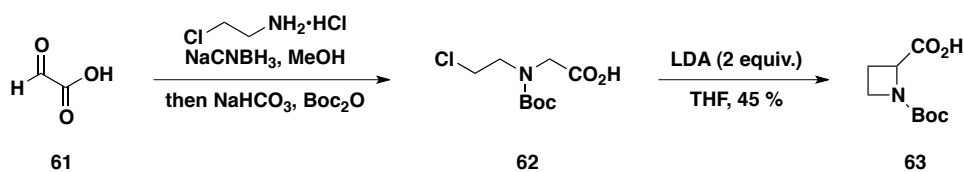

Scheme 1.11: Base-promoted synthesis of *N*-Boc-2-azetidine carboxylic acid.

In the same year the Shue group reported the synthesis of *cis*- and *trans*-3-phenylazetidine-2-carboxylic acids using a similar ring closing strategy.²⁴ Conversion of *tert*-butyl bromoacetate (**64**) to the amine (**65**), followed by reduction and treatment with thionyl chloride generated chloropropylamine **66** in excellent yield. Cyclization of **66** upon treatment with NaHMDS resulted in formation of azetidine **67** (Scheme 1.12). Removal of the *N*-benzyl groups and

the *t*-butyl esters provided a mixture of the *cis* and *trans* isomers **68a** and **68b** in overall yields of 35 % and 6 % respectively.

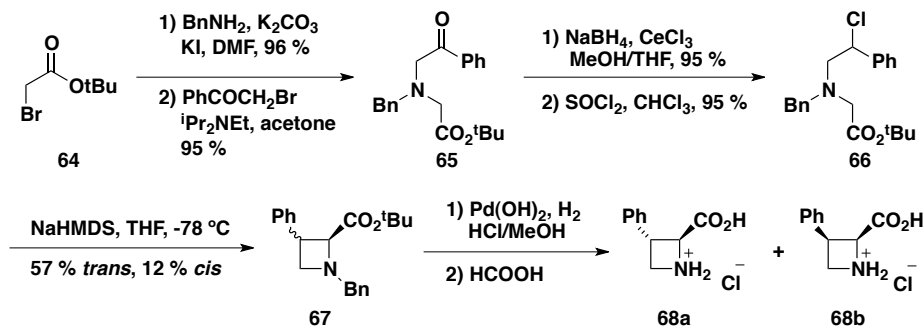

Scheme 1.12: Synthesis of 2,3-disubstituted azetidines through carbon-carbon bond formation.

More recently, a non-racemic approach to azetidines with varied substitution was reported starting from commercially available enantiopure 1,3-amino alcohols.²⁵ The synthesis of 2,4-disubstituted azetidine **73** was achieved starting from (*S*)-phenylalanol (**69**, Scheme 1.13). This procedure involved reductive amination of **69** to give *N*-benzyl (*S*)-phenylalaninol **70** followed by generation of oxazolidine **71** in the presence of formaldehyde. Subsequent ring opening with potassium cyanide in the presence of citric acid followed by chlorination gave **72**, which cyclized to a mixture of diastereomeric azetidines **73a** and **73b** when treated with LiHMDS.

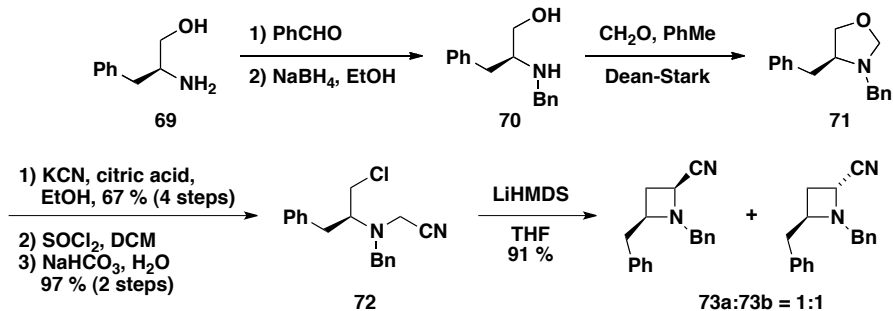

Scheme 1.13: Synthesis of azetidines from (*S*)-phenylalaninol.

Disubstituted amino alcohols (1*R*,2*S*)-ephedrine (**74**) and (1*S*,2*S*)-pseudoephedrine (**75**) can also be utilized in this methodology to generate 2,3,4-trisubstituted azetidines (Scheme 1.14). Both compounds **74** and **75** were alkylated with bromoacetonitrile in the presence of base to give amines **76** and **77**. The hydroxyl groups were then converted to the chlorides before treatment with LiHMDS, which led to diastereomeric mixtures of tri-substituted azetidines **80** and **81**. The diastereomeric ratios obtained for the tri-substituted products are superior to that of disubstituted azetidine **73** (Scheme 1.13). The authors were also pleased to report that there is no loss of enantiopurity during this process.

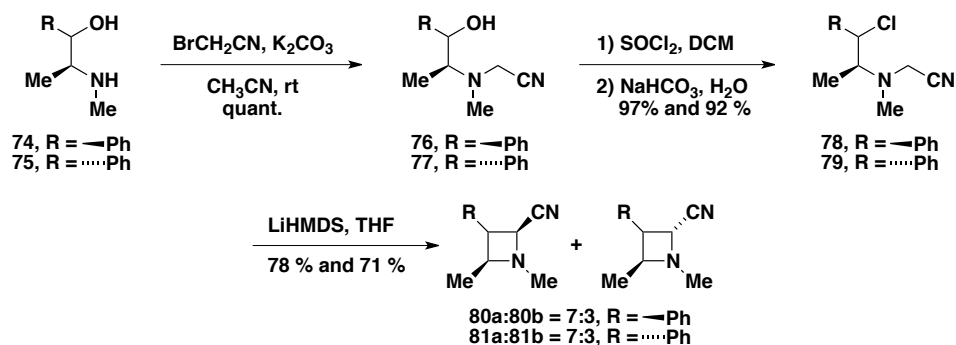

Scheme 1.14: Synthesis of azetidines (1*R*,2*S*)-ephedrine and (1*S*,2*S*)-pseudoephedrine.

Subsequent reports by the Couty group have shown that these 2-cyanoazetidines (**82**) are very versatile to further transformations (Scheme 1.15). The cyano group can be hydrolyzed to give azetidinic amino acids or esters (**83**), reacted with nucleophiles to form α -amino aldehydes and ketones (**84**) and β -amino alcohols (**85**), reduced to provide β -amino amines (**87**) and olefinated to produce 2-vinyl azetidines (**88**).^{26, 1d}

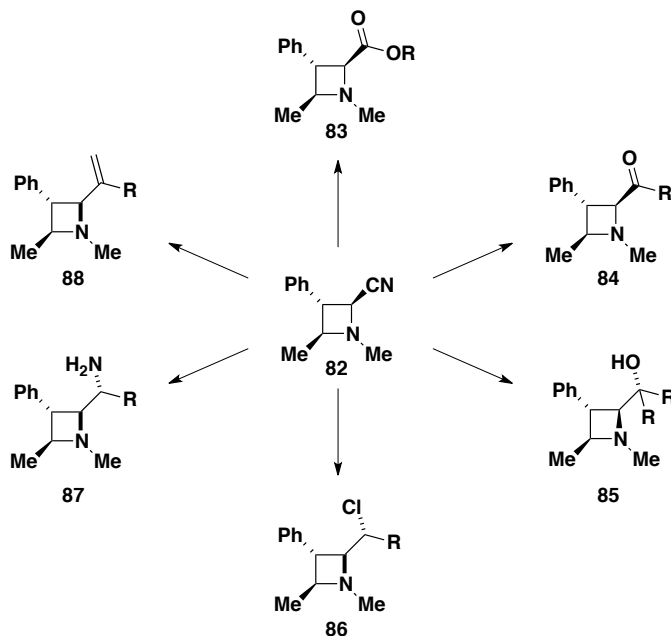

Scheme 1.15: Derivatives accessible from 2-cyano-azetidines.

A practical extension reported by this group has been the synthesis of azetidines by intramolecular Michael addition (Scheme 1.16). Conversion of the hydroxyl group of **89** to α,β -unsaturated ester **90** by a one-pot oxidation/Wittig protocol, followed by treatment with LiHMDS yielded a 1:1 mixture of azetidines **91a** and **91b**, epimeric at C-2. This method expands the potential of this reaction to include products with different handles on the 3-position.

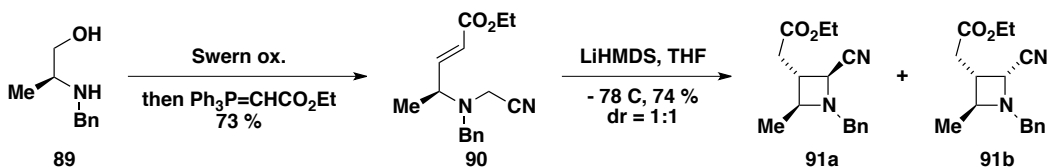

Scheme 1.16: The application of Michael addition towards azetidine synthesis.

All of the above ring closures have been the result of selective deprotonation of an acyclic substrate with strong base followed by ring formation. An attractive contrast to this method is the use of a photochemical Norrish-Yang type cyclization process reported by the Wessig group (Scheme 1.17).²⁷ Starting from enantiopure aminodiols **92** they were able to synthesize ketone **93**, which

upon irradiation formed biradical intermediate **VI**. Recombination of the biradical furnished azetidine **94**.

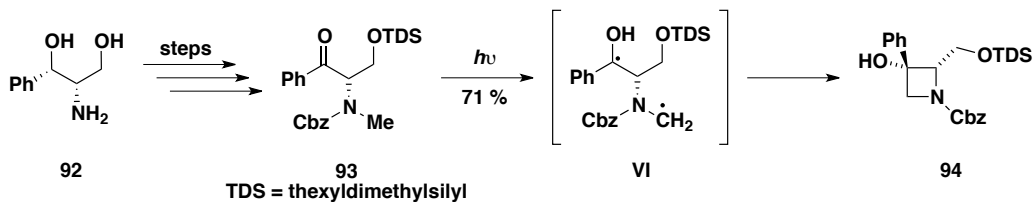

Scheme 1.17: Azetidines from radical cyclization α -methylamino ketones.

1.3.3. Reduction of β -Lactams and Cycloaddition Reactions

The construction of azetidines by cycloaddition reactions has mainly focused on the formation of β -lactams followed by subsequent reduction of the carbonyl. There are a variety of stereoselective methods available to generate the β -lactam framework. The reaction of a ketene (**95**) with an imine (**96**), known as the Staudinger reaction, is one of the most commonly used methods for the formation of β -lactams (**97**) (Scheme 1.18).^{28, 1b}

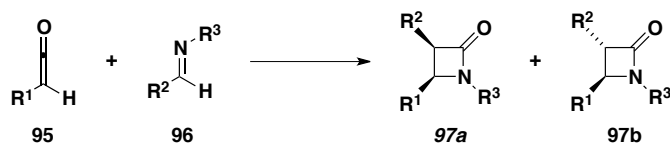

Scheme 1.18: The Staudinger reaction for β -lactam synthesis.

This reaction proceeds through a stepwise mechanism where the imine nitrogen reacts with the ketene carbonyl forming a zwitterionic intermediate which then cyclizes to give the desired product (Scheme 1.19). The nitrogen attacks from the less hindered side of the ketene in a perpendicular fashion resulting in intermediate **VII** with R_L(large) and R¹ in the same side. Concurrent rotation of the iminium into the plane of the C-C double bond and conrotatory ring closure furnishes the *cis*-substituted product **97a**. Conversely, when R¹ can

stabilize a positive charge, isomerization of intermediate **VII** to **IX** followed by ring closure results in R_L and R^1 being *trans* to one another in the final product (**97b**). This method can tolerate a wide range of functional groups and provides good diastereoselectivity when the substrates are appropriately substituted.

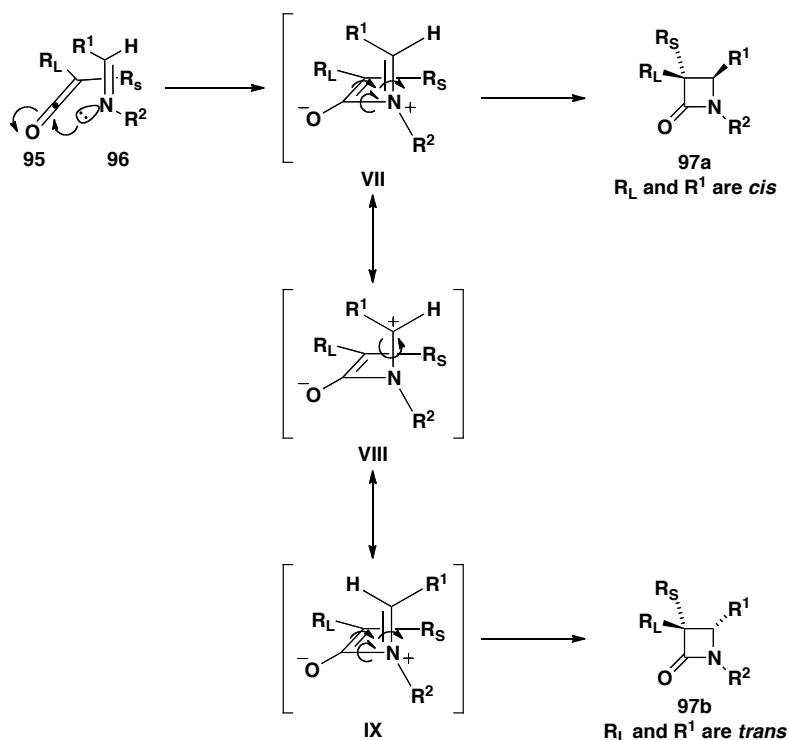

Scheme 1.19: Mechanism of the Staudinger reaction.

A related process for the generation of β -lactams is the [2+2]-cycloaddition of isocyanates with olefins (Scheme 1.20). Chlorosulfonylisocyanate (**98**) is a readily available reagent often used because of its high reactivity and the easy removal of the chlorosulfonyl group on nitrogen.²⁹ Although related to the Staudinger reaction, the mechanism of this cycloaddition process is concerted. The geometry of the olefin (**99**) controls the relative stereochemistry of the products (**100**), with *cis* olefins leading to *syn* products and *trans* to *anti*. Diastereomeric mixtures, however, are produced if epimerization occurs during the removal of the chlorosulfonyl protecting group to give the free β -lactams (**101**).

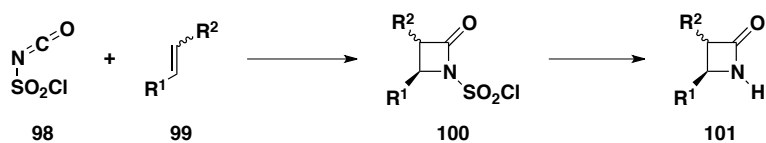

Scheme 1.20: β -lactams from the [2+2]-cycloaddition of chlorosulfonylisocyanate and olefins.

Reduction of β -lactams, such as those formed using the above-mentioned routes, can be effected with a number of different reagents. That said, the use of DIBAL-H and chloroalanes has emerged as the most efficient method as it does not lead to reductive ring opening, a problem often observed with the use of diborane, LiAlH₄ and Raney nickel.^{1b}

Although the reduction of β -lactams can be a fine approach to azetidines there can be problems associated with the reduction of other functional groups present in the molecule. For that reason several groups have looked into using a cycloaddition methodology to access azetidines directly. In 1995, Uyehara and coworkers reported a Lewis-acid promoted reaction of *N*-substituted aldimines (102) with allyltrisopropylsilane (103, Scheme 1.21).³⁰ The reaction is postulated to go through an intermediate β -silyl cation (X), which is stable at -78 °C but upon warming to room temperature cyclizes to a mixture of *cis* and *trans* azetidines (104a and 104b).

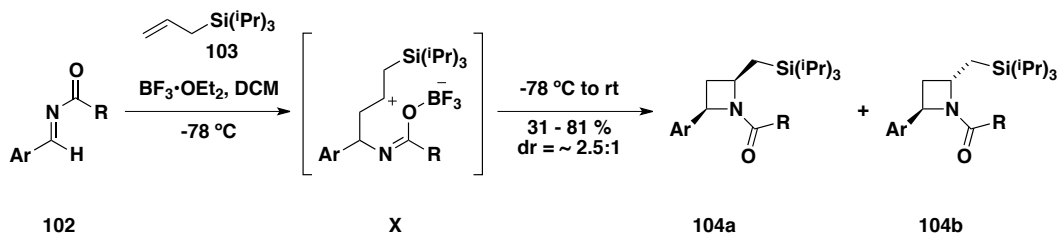

Scheme 1.21: Synthesis of azetidines by cyclization of aldimines with allyl silanes.

In 2003, while investigating the aza-Baylis-Hillman reaction of *N*-tosylimines (105) with ethyl 2,3-butadienoate (106), Shi and coworkers came across an interesting tactic for the synthesis of azetidines (107) when DABCO

was used as the catalyst (Scheme 1.22).³¹ A very recent expansion of this novel transformation allows for the formation of enantiomerically enriched products (85-98 % ee) when DABCO is replaced with cinchona alkaloid-derived base **108** (Scheme 1.23).³²

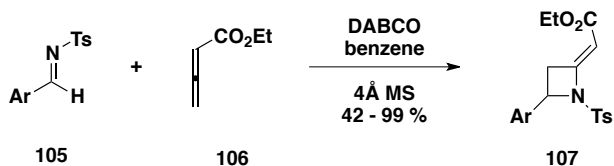

Scheme 1.22: Azetidine formation under Baylis-Hillman conditions.

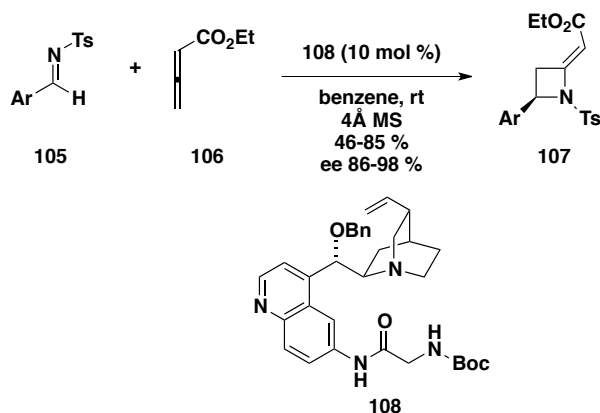

Scheme 1.23: Asymmetric synthesis of azetidines using a cinchona alkaloid catalyst.

A plausible mechanism for this “abnormal” aza-Baylis-Hillman reaction is shown in Scheme 1.24. The authors suggest that the use of DABCO allows for preferential attack on the imine by the γ -position of the Baylis-Hillman adduct **XI**, leading to amide **XII**, which closes to the four-membered heterocycle.

A recent report from the Fan group allows for the stereoselective construction of azetidines using a conceptually distinct iodine-mediated oxidative cyclization (Scheme 1.25).³³ Addition of 2-aminomalonnate **108** into chalcones **109** provided Michael adduct **110**, which upon treatment with iodosobenzene in the presence of tetrabutylammonium iodide gave azetidine **111** as a single diastereomer.

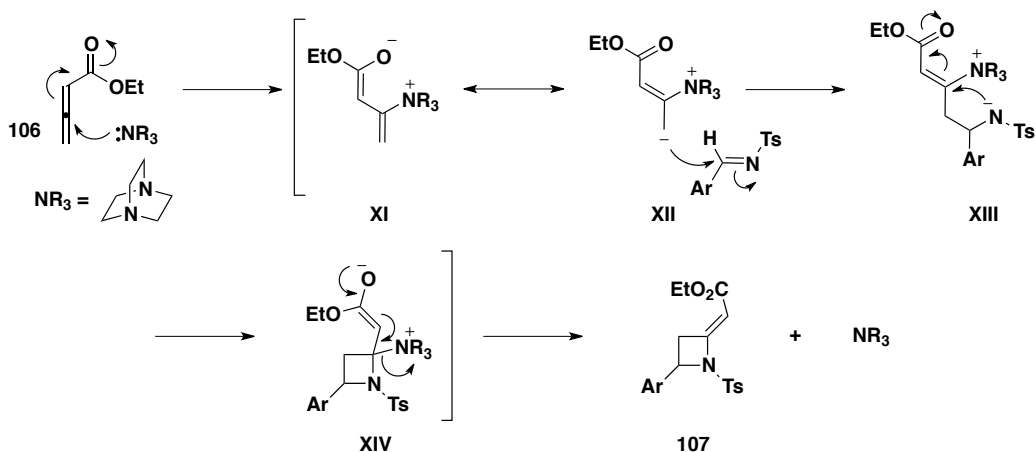

Scheme 1.24: Mechanism of the "abnormal" Baylis-Hillman reaction.

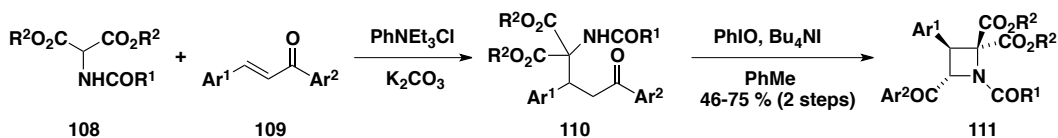

Scheme 1.25: Azetidine formation using an iodine-mediated oxidative cyclization.

The mechanistic hypothesis proposed by the group was based on the results of several important control experiments. The authors believe that there are two viable pathways to generate the final products from Michael adduct **110** (Scheme 1.26). Pathway **a** starts with reaction of the amide nitrogen of **108** with iodine(III) species **112** generated from reaction of iodosobenzene with tetrabutylammonium iodide. Intermediate **XV** next undergoes an intramolecular reductive elimination to give azetidine **111**. The alternate mechanism, pathway **b**, involves tautomerization of the ketone followed by hyperiodination of the enol leading to intermediate **XVI**. Intramolecular attack by nitrogen with concomitant reductive elimination of PhI would also generate azetidine **111**.

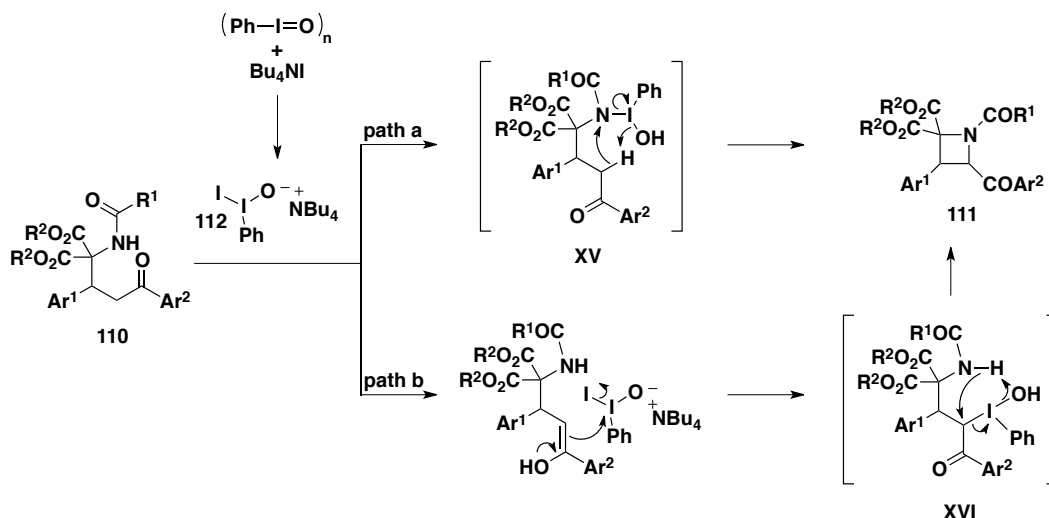

Scheme 1.26: Possible mechanisms for oxidative cyclization.

The ability to synthesize the azetidine framework in good yield from the readily available, versatile building blocks has opened the door for the use of these compounds in other synthetic applications. One possible limitation in many of these approaches is the use of phenyl or aryl groups to direct the stereochemical outcome and increase the stability of the reactants/products. Fortunately, reports in the literature for the conversion of phenyl groups to carboxylic acids on these types of strained ring systems (see Scheme 1.4) makes this approach more amenable for other applications.

1.4. Synthetic Application of Azetidines

As mentioned in the introduction to this chapter, the ring strain energy associated with the azetidine system is quite high (~25 kcal/mol), which makes it a good building block for a wide variety of secondary transformations that result in lower energy products. This section will illustrate the versatility of this small ring system, which provides access to many different types of structures by different modes of nitrogen activation.

1.4.1. Ring-Opening to Acyclic Amines

Azetidines can behave similarly to either aziridines or pyrrolidines under different reaction conditions. One way that azetidines behave similarly to aziridines is in their capacity to undergo nucleophilic ring opening to give acyclic products. Activating the nitrogen of an azetidine with Lewis or Brønsted acid followed by addition of an external nucleophile has been found to effect ring opening of azetidines. Mann and coworkers have utilized $\text{BF}_3 \cdot \text{OEt}_2$ to activate the nitrogen of *N*-nosyl or *N*-tosyl-2-phenylazetidines (**113**, Scheme 1.27).³⁴ After activation, the addition of allylsilanes (**114**) provided access to amino-olefins **115**. This ring opening was regioselective, occurring at the benzylic position, and is most likely due to polarization of the benzylic C-N bond upon complexation of the Lewis acid with nitrogen.

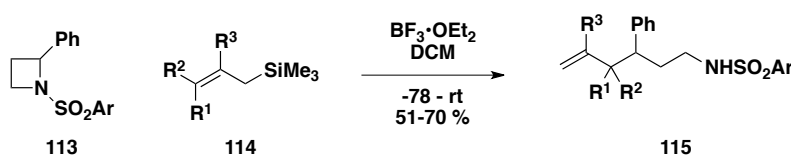

Scheme 1.27: Lewis-acid catalyzed opening of azetidines with allylsilanes.

Aryl-borates have also successfully been employed for the ring opening of *N*-tosyl-2-phenylazetidine (**116**, Scheme 1.28).³⁵ In this case, the Lewis acid is playing a dual role as both the activating agent and the nucleophile in the construction of amino aryl ethers (**117**). Several observations noted by the authors during this work give insight into some of the pros and cons of this methodology for the facilitation of ring opening. First, switching the protecting group on nitrogen from tosyl to methyl resulted in none of the ring-opened product being observed. This suggests that the protecting group on nitrogen must be electron withdrawing and could be a limitation for Lewis acid-promoted ring openings if its removal is difficult. The second observation was that the reaction of enantiopure *N*-tosyl-2-phenylazetidine with aryl borates gave a racemic product. This racemization, most likely due to ring opening to a carbocation intermediate,

suggests that the strength of Lewis acid complexation with nitrogen and the carbocation stabilizing ability of the group on the 2-position are crucial components that need to be fine-tuned for a successful stereospecific ring opening.

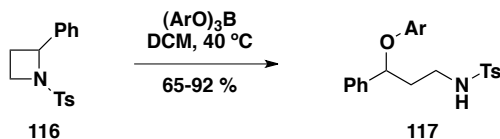

Scheme 1.28: Ring opening of azetidines with aryl borates.

A unique synthesis of enantiomerically pure α,β -unsaturated acyl silanes was accomplished through the Brønsted acid catalyzed ring opening of properly functionalized azetidines (Scheme 1.29).³⁶ Starting from 1-methoxyallenylsilane **118** and α -imino ester **119** the authors were able to synthesize azetidine-2-carboxylate **120** in 90 % yield and 97 % ee in the presence of catalytic $[\text{Cu}(\text{MeCN})_4]\text{BF}_4$ and (*R*)-Tol-BINAP. Treatment with acid then afforded the desired acyl silane **121** with no erosion of enantiopurity.

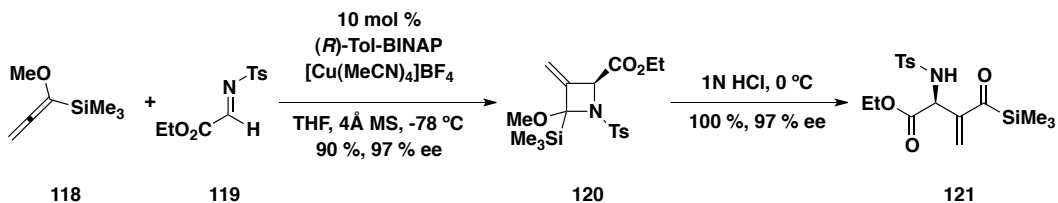

Scheme 1.29: Formation of acylsilanes via acid-mediated ring opening of azetidines.

In 2006, the Couty group reported an investigation into the reaction of *N*-methyl and *N*-benzyl azetidines with chloroformates.³⁷ The reaction of tertiary amines with chloroformates is well established in the literature as a method for the selective removal of *N*-methyl or *N*-benzyl groups.³⁸ The authors, who wanted to determine whether this process was also applicable to azetidines, found instead that treating azetidines **122** with methylchloroformate **123** resulted in the formation of *N*-protected γ -chloramines (**124**) in good to excellent yields (Scheme 1.30).

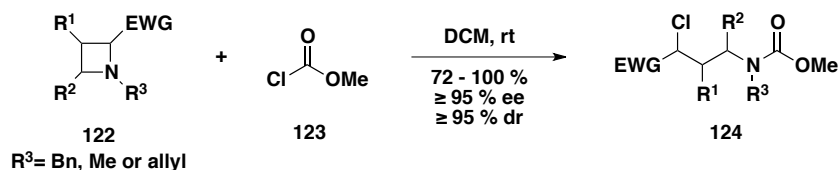

Scheme 1.30: Ring opening of azetidines with methylchloroformate.

In general, the ring opening was found to be highly regioselective, with the chloride anion attacking the more electrophilic position, and stereospecific, occurring via a S_N2 displacement. No erosion of enantiopurity or change in diastereomeric ratio was detected. This ring opening, unlike those associated with Lewis acid activation as mentioned above, allowed for exocyclic alkyl groups to be present on nitrogen and resulted in an easily removable protecting group thereafter.

An interesting observation was made when the authors examined the influence of relative stereochemistry of the starting materials on the products (Scheme 1.31). A comparison of **122a-d** showed that the all *syn* azetidine **122c** and the *anti-syn* azetidine **122d** produced **124c** and **124d** as well as products **125a** and **125b** from chloride attack at the less electrophilic center.

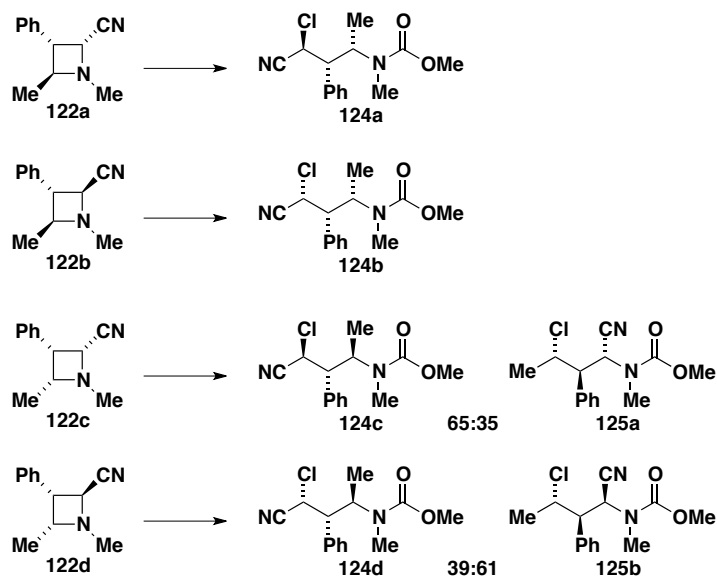

Scheme 1.31: Effect of relative stereochemistry on product formation.

Another aspect of azetidine ring activation that has recently been explored by the Couty group deals with ring-opening reactions of azetidinium salts.^{39, 1d} Starting with enantiopure azetidines (**126**), alkylation with methyl triflate gave the azetidinium salts (**127**), which could then be opened with a wide range of nucleophiles to give acyclic products **128-131** (Scheme 1.32). Successful nucleophiles include hydride, azide, amines, acetates, alkoxides, cyanates and malonate salts. In most cases the yields were good to excellent with no observable competition by eliminative pathways. When enantiopure azetidines were used as substrates the reaction occurred in a stereospecific manner.

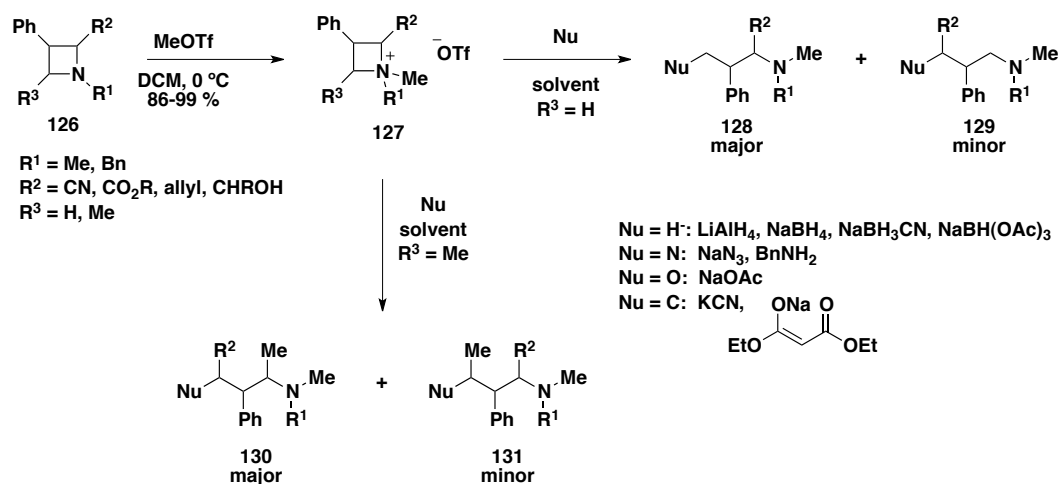

Scheme 1.32: Ring opening of azetidinium species with various nucleophiles.

It should be noted that a complementary example recently reported by Wang and coworkers using α -amido azetidine **132** allows access to γ -amino amides (**133**) with quaternary centers alpha to the carbonyl (Scheme 1.33).⁴⁰

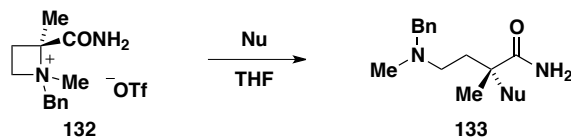

Scheme 1.33: Ring opening of azetidines to obtain amides with α -quaternary centers.

The high regioselectivity observed in these reactions strongly depends on the substitution pattern of the starting azetidine. In general, S_N2 attack at an unsubstituted α -carbon will occur preferentially over that of a substituted one. If both α -carbons possess substituents, however, nucleophilic attack occurs preferentially at the most electrophilic carbon center, which in the case of compound **127b** is C-2 (Scheme 1.34).

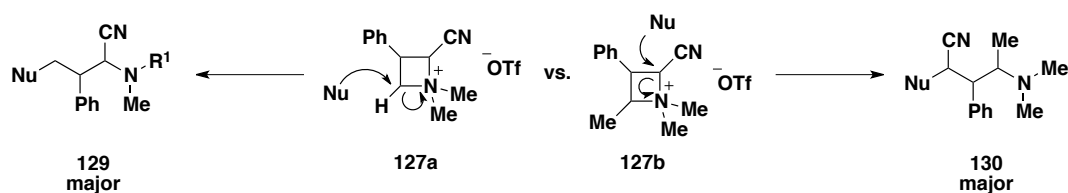

Scheme 1.34: Rationale for observed regioselectivity of ring opening.

As with the observations this group made regarding the ring opening of azetidines with chloroformates (*vide supra*), the authors again found that the starting geometry of the azetidine plays a major role in the outcome of the reaction. This is exemplified by the result of nucleophilic addition of sodium azide to 2,3-*trans* azetidine salt **127c** and 2,3-*cis* azetidine salt **127d** (Scheme 1.35).

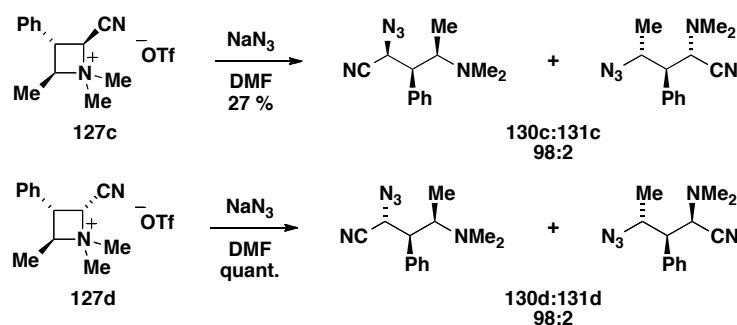

Scheme 1.35: Effect of relative stereochemistry on reaction yields.

The authors attribute this drastic difference in yield to the ability of each conformer to undergo nucleophilic opening (Scheme 1.36). For 2,3-*trans* azetidine **127c** the equilibrium should favour conformer **A** over conformer **B**; this

arranges all of the substituents in a *pseudo*-equatorial orientation. Unfortunately, due to blocking by the phenyl group, this preferred conformation (**A**) does not allow access to the electrophilic center for ring opening. Ring opening can only occur with conformer **B**, which suffers from several severe 1,3-diaxial interactions, thus rationalizing the poor yield of this transformation. With 2,3-*cis* azetidine salt **127d**, however, the conformer that allows for unhindered attack by the azide (conformer **D**) suffers less repulsive 1,3-diaxial interactions as the cyano group is in the equatorial position. Although this conformer is still less stable than **C**, the equilibrium will not be subject to the same level of bias as in the case of conformer **A** for compound **127c**.

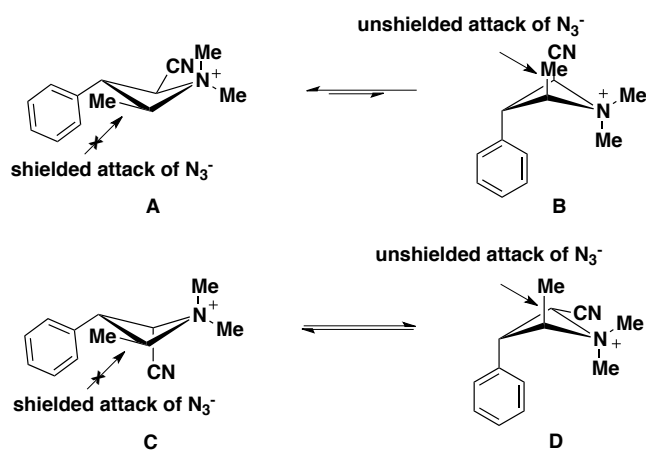

Scheme 1.36: Conformational preferences for nucleophilic attack by azide.

Several different hydride sources were tested as nucleophiles to compare the rate of ring opening and to determine whether the ester or cyano moieties could be preserved during the reaction.^{39d} The use of LiAlH_4 to open the ring was moderately successful but, as expected, reduced both ester and cyano groups to the alcohol or amine respectively. Making the switch to boron-derived reagents NaBH_4 and NaCNBH_3 enabled the authors to observe reductive ring opening in much higher yields while preserving the ester or cyano groups. The use of $\text{NaBH}(\text{OAc})_3$, on the other hand, surprisingly induced ring opening by attack with an acetate ion. The regioselectivity of the ring opening using the boron reducing

agents was the same as that observed with C, N and O-nucleophiles (see Scheme 1.32).

Exploration into the ring opening of azetidinium salt **127e** with carbon nucleophiles was successful with both potassium cyanide and the sodium salt of diethyl malonate (**134**), generating amines **128e** and **128f** respectively (Scheme 1.37).^{39c} Unfortunately, attempts at ring opening with several other carbon nucleophiles such as the enolates derived from ethyl acetoacetate (**135**), acetophenone (**136**) or *tert*-butyl acetate (**137**) resulted in the formation of azetidinium ylide **138** by deprotonation at the C-2 position.

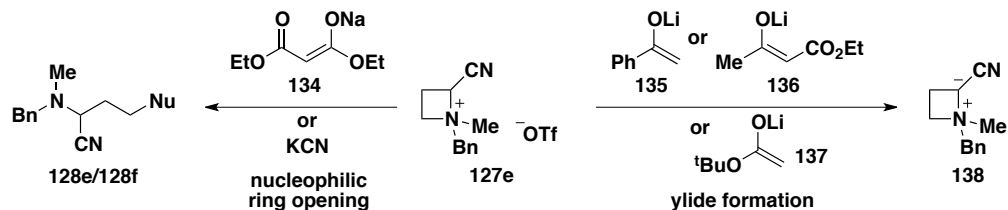

Scheme 1.37: Ring opening of azetidines with carbon nucleophiles.

Although the authors were initially disappointed by these results they did note that the formation of epoxide **139** from the reaction of azetidine **127e** with the enolate of acetophenone (**135**, Scheme 1.38). In open-chained or larger heterocycles the formation of an epoxide by displacement of an ammonium leaving group is not very successful due to the high energetic barrier for ring closure. With the use of a strained azetidinium ylide, however, the energy gain associated with breaking the four-membered ring compensates for that energy barrier and increases the feasibility of such an approach.

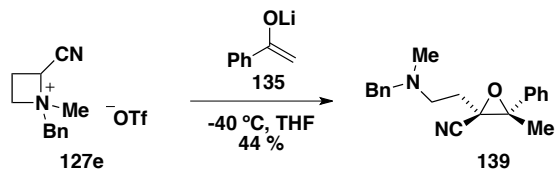

Scheme 1.38: Unexpected epoxide formation.

This observation led to the exploration of epoxide formation/ring opening with aldehydes and ketones.⁴¹ The proposed mechanism of the reaction is shown in Scheme 1.39. The reaction proceeds with the production of a single diastereomer and, when tested with enantiomerically pure starting materials produced enantiomerically pure products.

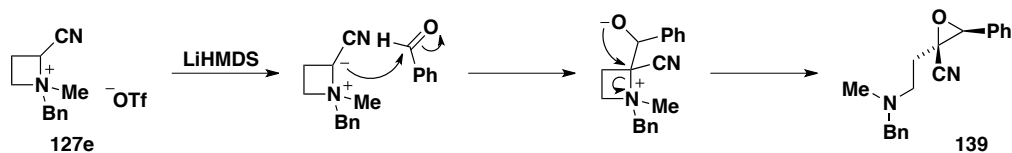

Scheme 1.39: Mechanism of epoxide formation.

In order to confirm the importance ring strain to the success of this reaction the authors synthesized the pyrrolidine analogue **140** and subjected it to the same reaction conditions (Scheme 1.40). The only reactivity observed with **140** was epimerization at the α -position to a mixture of **140/epi-140**. The authors state that this is due to the absence of any ring strain to help drive the reaction toward epoxide ring closure and thus results in the reversion back to the starting materials.

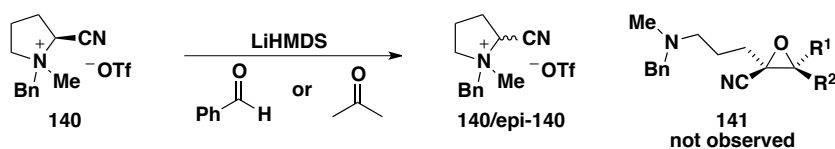

Scheme 1.40: Test reaction with pyrrolidine substrate.

This process was further extended to the formation of cyclopropanes (**143**) by the addition of azetidinium salt **127b** into Michael acceptors (**142**, Scheme 1.41).⁴² The cyclopropanation was shown by the authors to proceed via the mechanism shown in Scheme 1.42. Reversible 1,4-addition and potential ylide epimerization were found to occur during reactions performed by the authors in their search to understand the convergence of epimeric starting materials into one product.

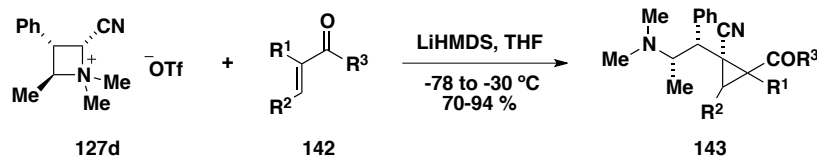

Scheme 1.41: Cyclopropanation of enones with azetidinium salts.

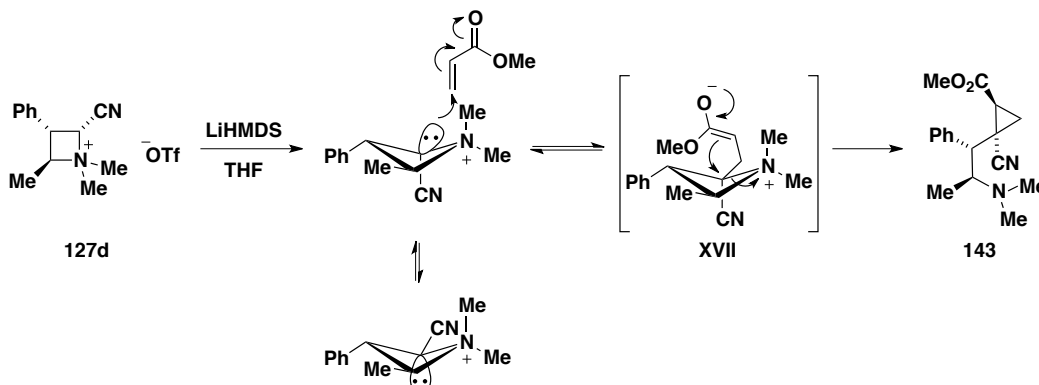

Scheme 1.42: Proposed mechanism of cyclopropanation.

Interestingly, when the authors again tested for the importance of ring strain in the success of the reaction by subjecting pyrrolidine analogue **140** to the same reaction conditions, they were able to isolate small amounts of the homologous cyclopropanated product **145** (Scheme 1.43). This was in contrast to the result shown in Scheme 1.40, when the same pyrrolidine ylide was exposed to an aldehyde electrophile, where the only reactivity observed was epimerization at the α -position of the pyrrolidinium salt. This suggests that there are other factors, such as the lesser ability of the cyclopropane product **145** to revert back to starting materials, involved in the outcome of the reaction.

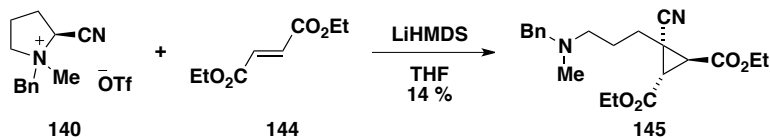

Scheme 1.43: Cyclopropanation with pyrrolidinium salts.

1.4.2. Ring Expansion to Pyrrolidines and Other 5-Membered Heterocycles

Although the ring expansion of azetidines to pyrrolidines was first observed several decades ago, the application of this process for synthetic purposes was not significantly developed until recently. Several research groups, including the West group, have explored the potential of the one-carbon ring expansion of azetidines to pyrrolidines in the last decade.

In 1970, Masuda and coworkers reported the ring expansion of *N*-*tert*-butyl-2-methanesulfonyloxymethylazetidine **146** to pyrrolidine **148** when it was left at room temperature for a few hours.⁴³ A similar result was obtained when they treated **146** with triphenylphosphine dibromide. The authors proposed that the reaction could proceed *via* either the quaternary ammonium salt **XIX** or the phosphonium salt **XVIII** (Scheme 1.44).

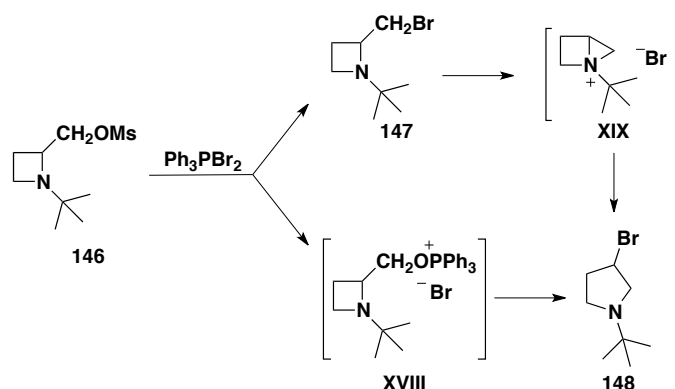

Scheme 1.44: Ring expansion of *N*-*tert*-butyl-2-methanesulfonyloxymethylazetidine with Ph_3PBr_2 .

Since the early observations by Masuda and coworkers several other groups have observed this ring expansion process in azetidines possessing reasonable leaving groups on the 2-methyl substituent. In 1999, Alcaide and coworkers observed the ring expansion of azetidine **149**, with either an acetal or thioacetal-protected aldehyde on the 2-position, when treated with

diethylaluminum chloride (Scheme 1.45).⁴⁴ In these examples the nature of the aldehyde protecting group had a large effect on the outcome of the reaction.

A few years later, a report concerning the formation of 1,2-dialkyl-4-halopyrrolidines (**156**) was published.⁴⁵ The authors generated 2-halomethylazetidines **154/155** from selenylated azetidine precursors (**153**) and upon subsequent heating these substrates underwent ring expansion to give **156** (Scheme 1.46).

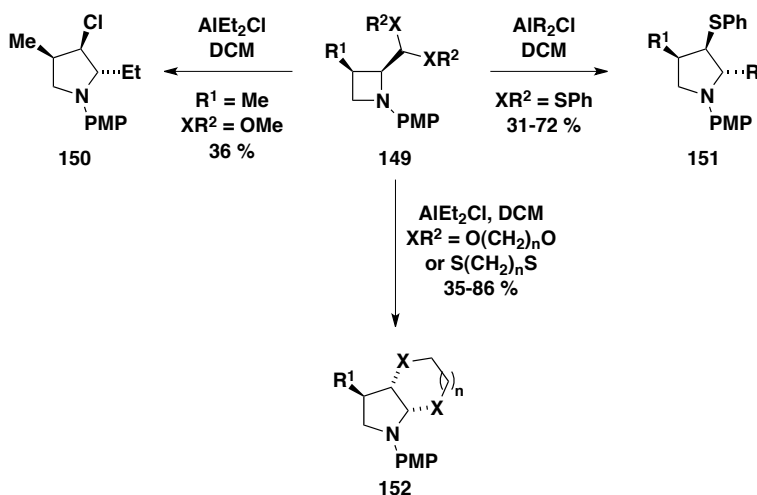

Scheme 1.45: Ring expansion of azetidines with chloroalanes.

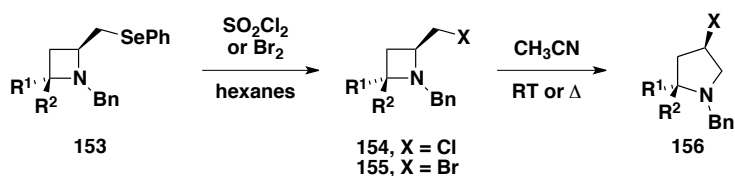

Scheme 1.46: Ring expansion of selenylated azetidines.

Around the same time, the Couty group had also begun an investigation into this process, looking in depth at how the nature of the leaving group, relative substitution and stereochemistry of the starting material affect the outcome of the reaction.^{26b, 46} To get a good idea of the effect each factor had on the reaction the

authors synthesized a variety of differently substituted, enantiopure azetidines with primary, secondary or tertiary α -hydroxyalcohols present on the 2-position.

Conversion of primary α -hydroxymethyl azetidines **157** and **160** to α -chloromethyl azetidines **158** and **161** using thionyl chloride proceeded in excellent yields. Subsequent ring expansion to 3-chloropyrrolidines **159** and **162** could be initiated upon heating to 120 °C in DMF, albeit in low to moderate yields (Scheme 1.47).

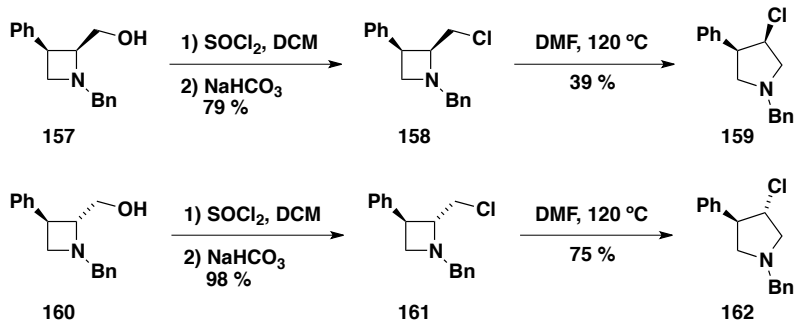

Scheme 1.47: Ring expansion of α -chloromethyl azetidines with retention of configuration.

Treatment of **157** and **160** with mesyl chloride at only room temperature, however, resulted in formation of both mesylates **163** and **165** as well as some of the pyrrolidine products. Full conversion to pyrrolidines **164** and **166**, in an overall higher yield than that observed with the chloride case, was accomplished by refluxing the crude mesylates in chloroform (Scheme 1.48).

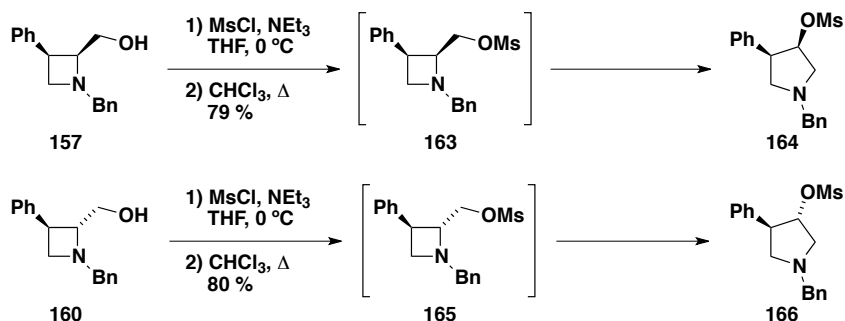

Scheme 1.48: Ring expansion of α -hydroxymethyl azetidines through activation with mesyl chloride.

Both of the above transformations resulted in formation of a single pyrrolidine product with the same relative stereochemistry as the starting azetidines. This suggested to the authors that the ring expansion is occurring *via* the intermediate aziridinium ion **XX** (Scheme 1.49). Recent computational experiments performed by the same group support this mechanism.⁴⁷ Additional reactions involving other primary α -hydroxymethyl azetidines suggest that multiple substituents on the ring are well tolerated and do not change the stereochemical outcome of the reaction.

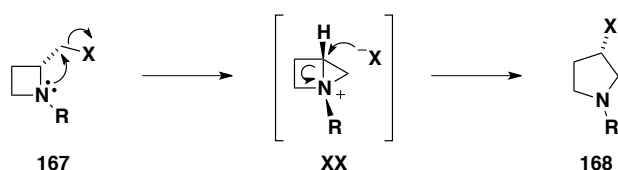

Scheme 1.49: Mechanism of ring expansion.

Activation of the secondary α -hydroxymethyl azetidines **169** and **171** with either the chlorination or mesylation conditions led to a diastereomeric mixture of activated products **170** and **172** (Scheme 1.50). This is may be due to the possibility of chlorination occurring via a S_N1 mechanism rather than the S_N2 mechanism seen with the primary α -hydroxymethyl azetidines **157** and **160** (Scheme 1.47 and Scheme 1.48). Subsequent ring expansion of either of the separable diastereomers occurred without incident. It should be also noted that a recent publication by De Kimpe and coworkers indicated that this problem can be solved by setting the stereochemistry of the chloride earlier in the azetidine synthesis.⁴⁸ Unfortunately, all attempts to ring expand tertiary α -hydroxymethyl azetidines only resulted in elimination products.

Addition of external nucleophiles such as hydroxide, cyanide, azide, acetate or fluoride allowed for generation of pyrrolidines (**174**) with a variety of substitutions at C-3 (Scheme 1.51). Most of these transformations were performed on the easily isolable chloro-substrates (**173**). The temperature of the reactions was found to be crucial for the formation of the desired products. Too

low a temperature resulted in ring expansion with only chloride acting as the nucleophile while too high a temperature led to eliminative byproducts.

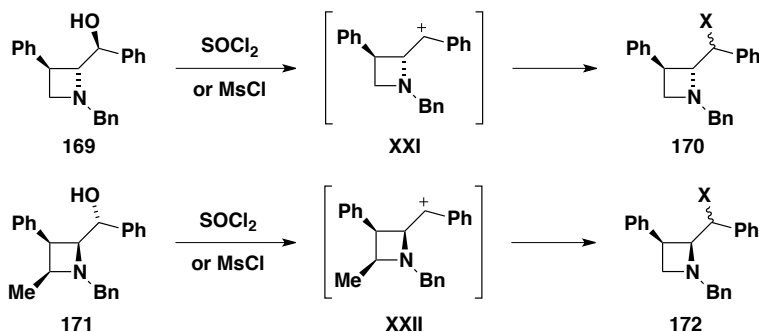

Scheme 1.50: Observation of diastereomeric products with secondary α -hydroxymethyl azetidines.

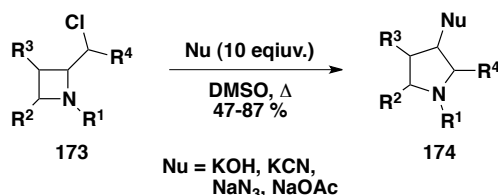

Scheme 1.51: Ring opening of α -chloromethyl azetidines with external nucleophiles.

Nucleophilic ring openings with fluoride were performed using diethylaminosulfur trifluoride (DAST), which works as both the hydroxyl activator and the source of fluoride (Scheme 1.52).⁴⁹

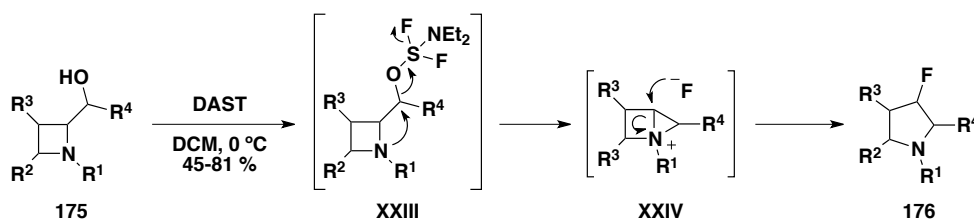

Scheme 1.52: Nucleophilic ring opening with DAST.

Ring-expansion of azetidines is also possible using Lewis acid activation. The $\text{BF}_3 \cdot \text{OEt}_2$ -mediated rearrangement of 2-aminomethylazetidines (**177**) provides access to 3-aminopyrrolidines **178** in moderate to good yields.⁵⁰ The

mechanism for this ring expansion is shown in Scheme 1.53 and involves coordination of the azetidine nitrogen to the Lewis acid (**XXV**), followed by concomitant aziridination and azetidine ring opening to give intermediate **XXVI**. Migration of the Lewis acid to the aziridine nitrogen then allows for a second intramolecular nucleophilic displacement to occur, opening aziridinium intermediate **XXVII** and to provide 3-aminopyrrolidine **178**.

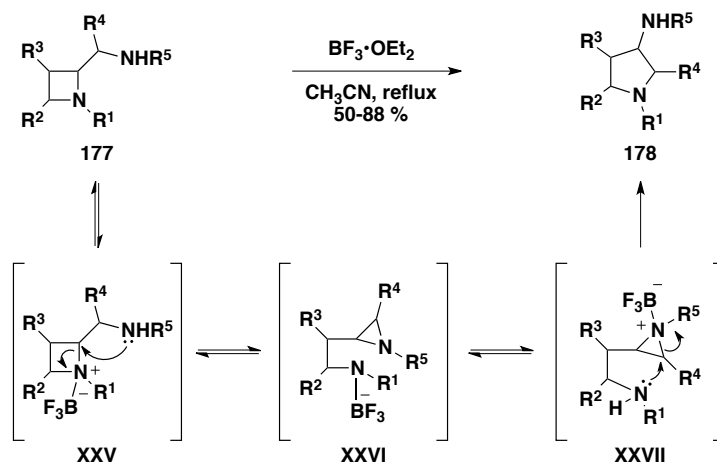

Scheme 1.53: Lewis acid activated ring expansion of α -aminomethyl azetidines.

This process, which provides access to highly substituted 3-aminopyrrolidines, was also applied to the synthesis of the pyrrolizidine alkaloid (-)-absouline (**185**, Scheme 1.54). The synthesis began with the addition of 3-benzyloxypropyl lithium to enantiomerically pure azetidine **179** followed by reduction of the resulting imine to give the desired 2-aminomethylazetidine (**180**) in 64 % yield and a dr of 25:1. Activation of the azetidine nitrogen with $\text{BF}_3 \cdot \text{OEt}_2$ initiated the ring expansion to pyrrolidine **181**, which was obtained in 80 % yield with no change in the diastereomeric ratio. Protection of the primary amine as the carbamate followed by removal of the benzyl protecting groups on both oxygen and the ring nitrogen by hydrogenolysis gave amino-alcohol **182**. Activation of the alcohol of **182** with triphenylphosphine resulted in a smooth cyclization to pyrrolizidine **183**. The synthesis was completed by standard removal of the *N*-

Boc protecting group and DCC-mediated coupling of the newly revealed primary amine with (*E*)-paramethoxycinnamic acid (**184**).

In the same year, the West group published a different approach to the pyrrolizidine alkaloid framework using the ring expansion of an azetidinium ylide and demonstrated its applicability in the synthesis of the natural products turneforicidine (**194**) and platynecine (**195**).⁵¹ This synthesis relied on a different mode of activation for the azetidine than any of those discussed above, utilizing the *in situ* generation of an ammonium ylide through reaction of a tertiary amine with a metallocarbene, followed by ring expansion *via* a Stevens [1,2]-shift.

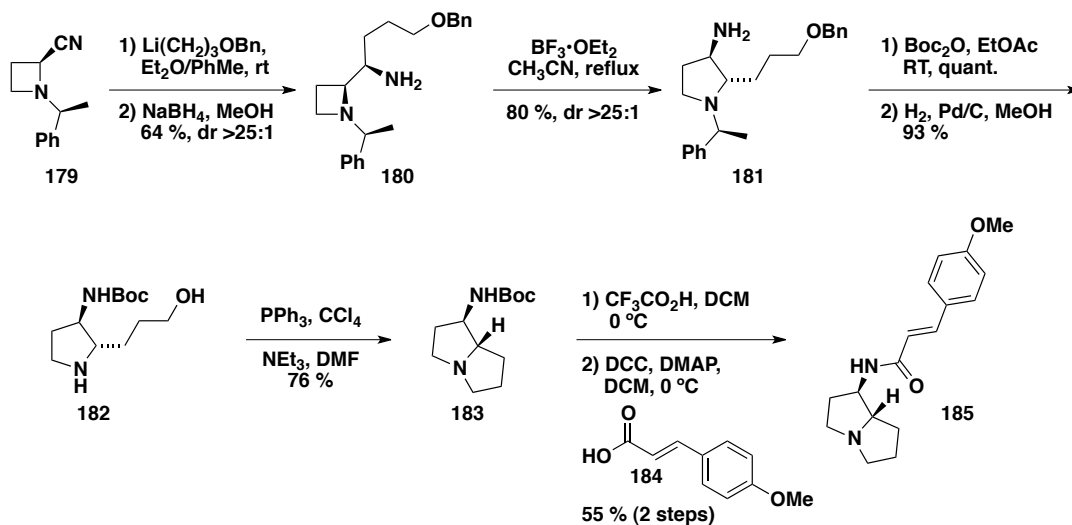

Scheme 1.54: Synthesis of (-)-absouline *via* an azetidine ring-opening strategy.

To examine the potential of this project the authors first decided to test the ring expansion of the azetidine in an intermolecular fashion (Scheme 1.55). Readily available methyl 1-benzylazetidine-2-carboxylate **186** was allowed to react with ethyl diazoacetate (EDA) in the presence of a copper catalyst. In general, the Stevens rearrangement involves a migration of the group that is best able to stabilize a radical intermediate. In unstrained systems this would result in preferential benzyl migration over ring expansion (migration of a RCHCO_2Me group).⁵² The authors hoped that the ring strain associated with the azetidine in this case would be a driving force for its expansion. The resulting product,

pyrrolidine **187**, was the result of the Stevens [1,2]-shift of the internal C-N bond bearing the CH₂CO₂Me group. The exciting result convinced the authors that the intramolecular version of this process could also be viable.

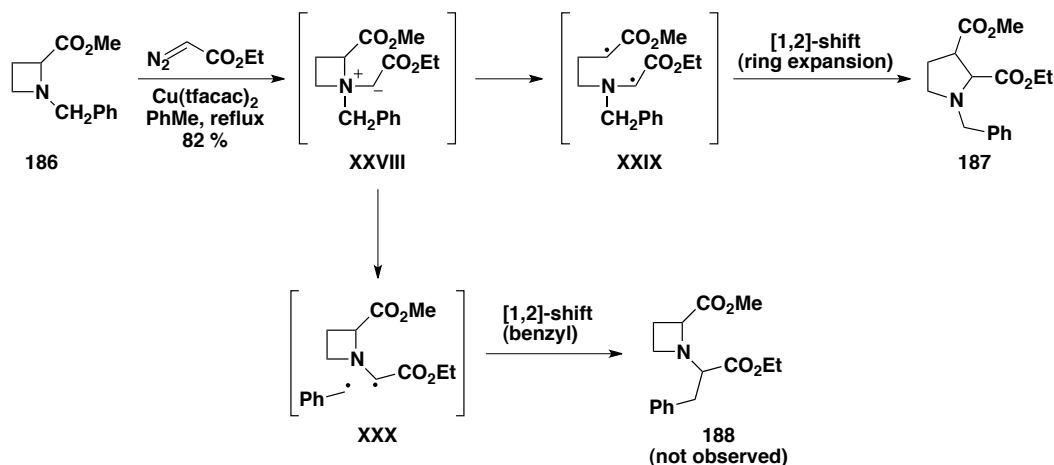

Scheme 1.55: Ring expansion of azetidines *via* Stevens [1,2]-shift.

The synthesis of the natural products also began with 1-benzylazetidine-2-carboxylate **186** (Scheme 1.56). Removal of the *N*-benzyl protecting group under transfer hydrogenation conditions followed by alkylation to incorporate the tethered diazo moiety provided the desired substrate **189** in excellent yield. Next, **189** was treated with 10 mol % Cu(acac)₂ and heated to reflux in benzene to initiate the formation of an ammonium ylide intermediate and promote the ring expansion to diastereomeric pyrrolizidines **190** and **191** in a ratio of 3.6:1. Subsequent reduction of the ketones in the presence of Adams catalyst gave hydroxyester **192** and lactone **193** respectively. Separation and subsequent reduction of **192** and **193** with LiAlH₄ led to the natural products turneforcidine (**195**) and platynecine (**195**).

Recently, West and coworkers have reported a more thorough examination into the ring expansion of azetidines (**196**) to pyrrolidines (**198**) *via* the Stevens 1,2-shift (Scheme 1.57).⁵³ This methodology, which is shown to tolerate a wide range of functional groups on both nitrogen and on the α -position of the ring, has led to a general procedure for the preparation of highly-substituted pyrrolidines in

one step from simple building blocks. The results of this investigation will be discussed in detail in Chapter 2.

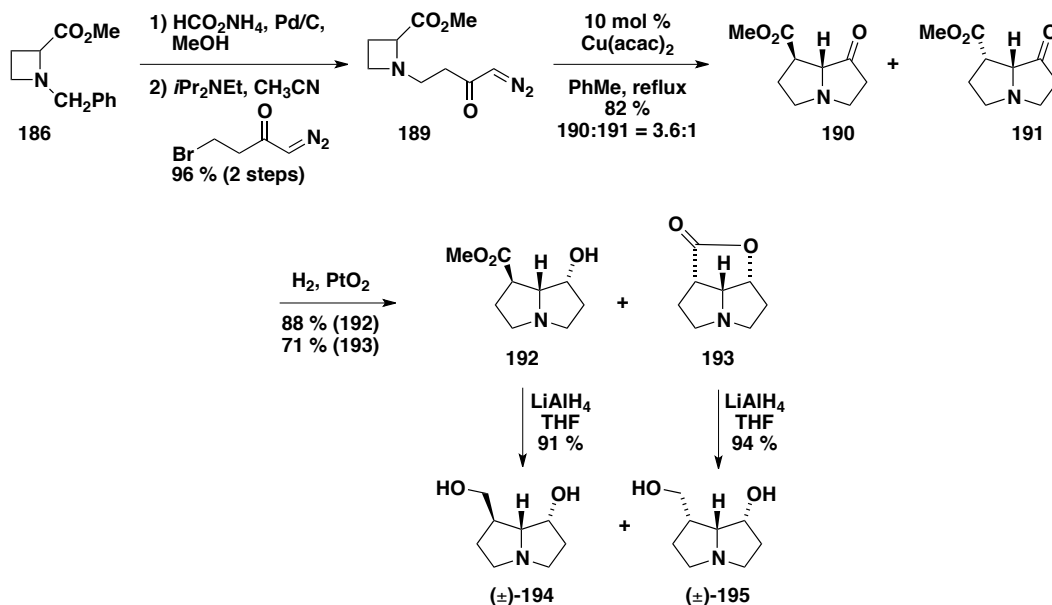

Scheme 1.56: Synthesis of the natural products (±)-turneforcidine and (±)-platynecine.

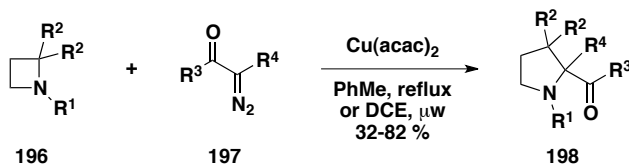

Scheme 1.57: One-step ring expansion of azetidines to pyrrolidines by the Stevens [1,2]-shift.

Alongside the obvious success in the ring expansion of azetidines to pyrrolidines there have also been reports of the successful conversion of azetidines to other 5-membered heterocycles. In 2000, the Concellón group reported the formation of 1,3-oxazolidines **200** when primary amines were added to a solution of enantiopure 3-hydroxyazetidinium salts **199** in dichloromethane (Scheme 1.58).¹⁹ The intermediate ring-opened diaminoalcohol **XXXI** reacts *in situ* with dichloromethane to generate the 1,3-oxazolidine.

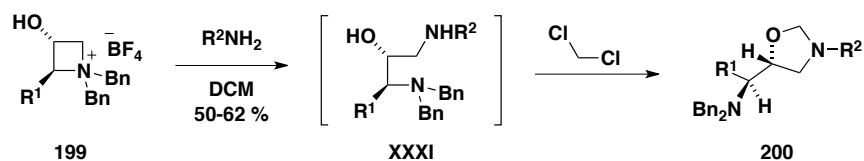

Scheme 1.58: Ring expansion of azetidines to 1,3-oxazolidines.

Another class of 5-membered ring heterocycles that is commonly used in organic synthesis and can be accessed from azetidines is the oxazolidinones. Oxazolidinones are very important molecules for asymmetric synthesis and are commonly employed as chiral auxiliaries.⁵⁴ In 2011, the Couty group reported a synthesis of chiral oxazolidinones by activation of α -hydroxymethyl azetidines **201** with bis(trichloromethyl) carbonate (BTC), which is a safer substitute for phosgene.⁵⁵ This reaction, which proceeds through bicyclic azetidinium intermediate **XXXII**, followed by nucleophilic ring opening with chloride ion, allows for the formation of a wide variety of enantiomerically pure oxazolidinones (**202**) in good to moderate yields (Scheme 1.59).

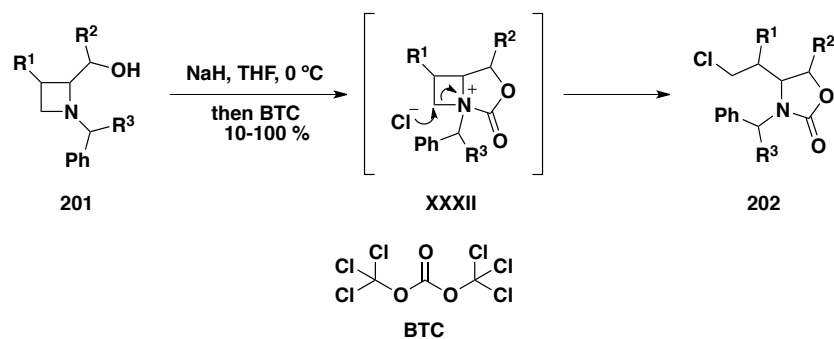

Scheme 1.59: Ring expansion of azetidines to oxazolidinones.

One drawback the authors noted was that the placement of a substituent on the azetidine at the 4-position resulted in conversion of the α -hydroxymethyl azetidine **203** into the α -chloromethyl azetidine **204** without any of the desired oxazolidinone being detected. This is most likely due to steric hindrance by the substituent at C-4 preventing attack by the chloride at that position (Scheme 1.60).

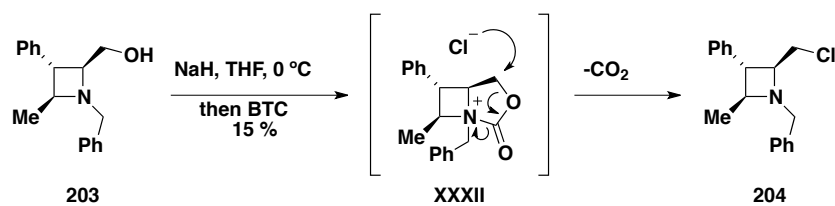

Scheme 1.60: Failed ring opening of 4-substituted azetidines.

1.4.3. Ring Expansion to Six-Membered Heterocycles

The expansion of the azetidines to piperidines was first reported by the De Kimpe group as an extension of their work towards pyrrolidine synthesis mentioned previously.⁵⁶ The authors were able to synthesize enantiopure 2-(2-bromoalkyl)azetidines (**205**) which, upon heating, closed to the bicyclic azetidinium intermediate **XXXIII** (Scheme 1.61). Nucleophilic attack by the bromide ion opened **XXXIII** to 4-bromopiperidine **206**. Ring opening with external nucleophiles such as hydroxide, azide or cyanide has also been successful, allowing access to other 4-substituted piperidine derivatives.

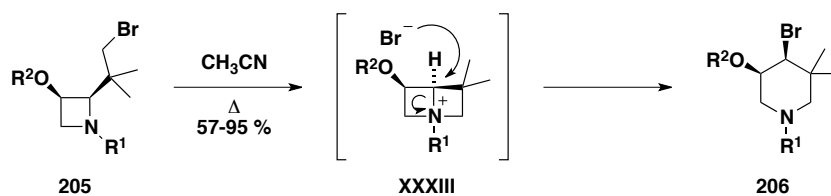

Scheme 1.61: Ring expansion of azetidines to piperidines.

The Ghorai group has published several papers on the activation of 2-aryl-*N*-tosylazetidine **207** with either Zn(II) or Cu(II) Lewis acids followed by ring opening of the activated intermediate (**XXXIV**) with either a nitrile or carbonyl nucleophile.⁵⁷ This approach is similar to that of the activation with $\text{BF}_3 \cdot \text{OEt}_2$ described previously and resulted in [4+2] adducts **208** and **209** (Scheme 1.62). Their recent expansion of this methodology to include more highly substituted and enantiopure starting materials adds a great deal of potential to this process.

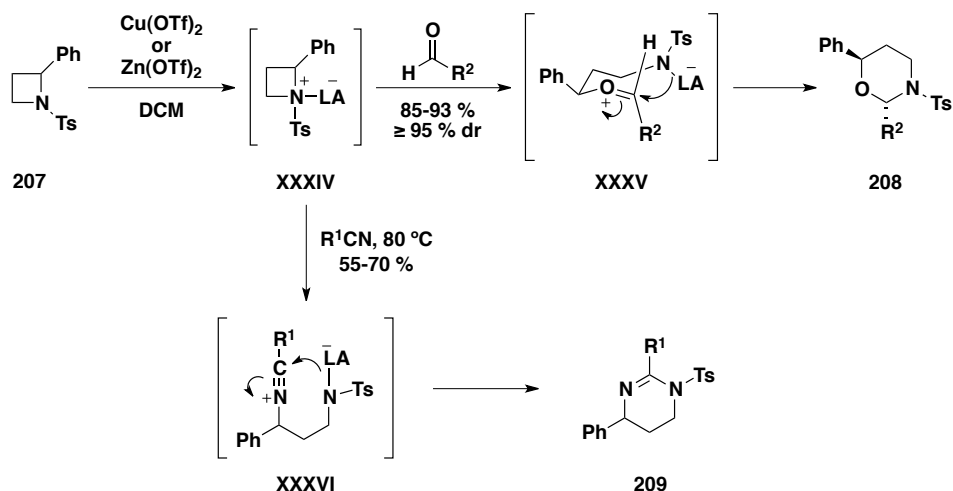

Scheme 1.62: [4+2]-cycloadducts by opening of azetidines with nitriles or aldehydes.

1.4.4. Ring Expansion to Medium-Sized Heterocycles

The formation of medium-sized rings (between 8-12 atoms) is one of the more challenging problems faced by synthetic chemists. This is largely due to destabilization of the products, and the transition states on route, *via* the transannular effects (unfavourable interactions) experienced in these systems.⁵⁸ In the beginning of this chapter it was noted that the ease of forming azaheterocycles generally follows the order of 5>3>6>7≈4. This being said, there has been a great deal of interest in the formation of medium-sized 7 and 8-membered azaheterocycles, largely due to the substantial number of natural products that contain these moieties.

As discussed in the above section, the formation and subsequent ring expansion of azetidinium ylides is a viable method for the synthesis of functionalized pyrrolidines. The Couty group has reported two variations on this methodology to access both azepine and azocine derivatives.⁵⁹ The first method, reported in 2006, was found to generate either 2,3,6,7-tetrahydroazepines (**211**) or pyrrolidines (**212**) depending on the geometry of the starting azetidine.^{59a} The authors synthesized a variety of 2-alkenyl-azetidines (**210**), which were then alkylated to give the azetidinium triflate salts in excellent yields. Treatment of

these salts with a strong base generated the ylide intermediate **XXXVI** which subsequently underwent a [1,2]-shift to give pyrrolidine **212** or a [2,3]-sigmatropic rearrangement to give 2,3,6,7-tetrahydroazepine **211** (Scheme 1.63).

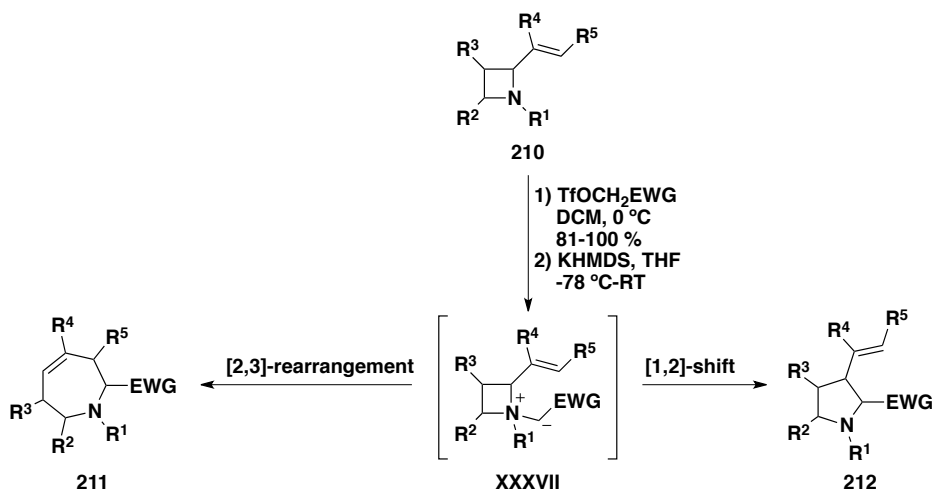

Scheme 1.63: Formation of 2,3,6,7-tetrahydroazepines or pyrrolidines from azetidinium ylides.

The outcome of the reaction was dependent on the geometry of the alkenyl substituent on the 2-position of the azetidine ring relative to the newly formed carbon-nitrogen bond after *N*-alkylation. The [2,3]-rearrangement occurs when these substituents are *cis* to one another while the [1,2]-shift product is the result of a *trans* relationship (Scheme 1.64).

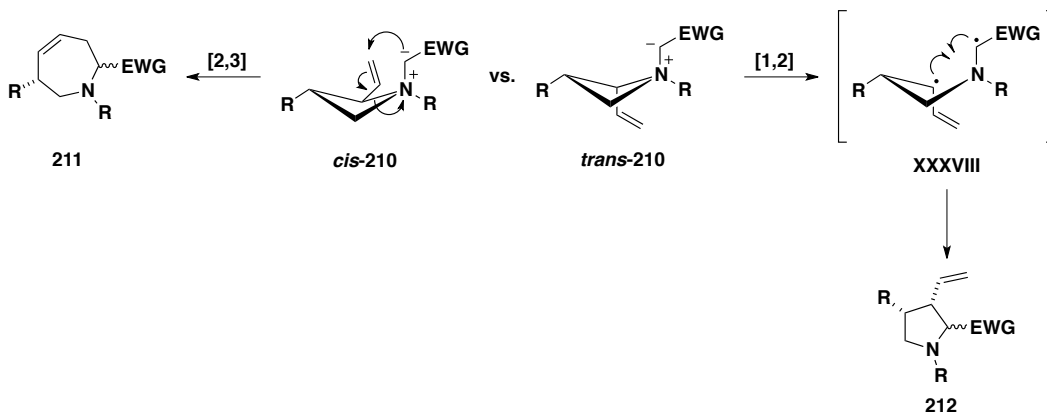

Scheme 1.64: Explanation for observed reactivity of *cis* and *trans* 2-alkenylazetidines.

A slight modification to this procedure allowing for access to azocine derivatives with the same 2-alkenyl azetidines (**210**) was reported a few years later.^{59b} In this case, activation of the nitrogen by alkylation with activated alkynes leads to intermediate **XXXIX**, which can subsequently undergo a [3,3]-sigmatropic rearrangement to give the 1,2,3,6-tetrahydroazocines (**213**, Scheme 1.65).

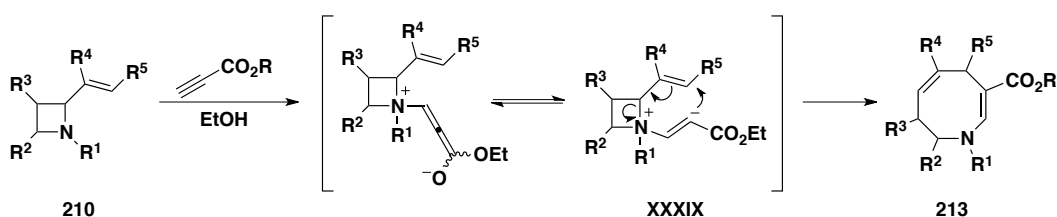

Scheme 1.65: Mechanism of eight-membered ring formation.

The formation of the desired product (**213**) was found to be sensitive to the relative configuration of the substituents on the ring. The authors found that ring opening of **210a** to give acyclic product **215** was competitive with the formation of **213a** (Scheme 1.66), which was consistent in other cases where R^4 and/or $R^5 \neq H$ (Scheme 1.65). This is believed to be the result of steric congestion impeding the requisite conformation for the rearrangement.

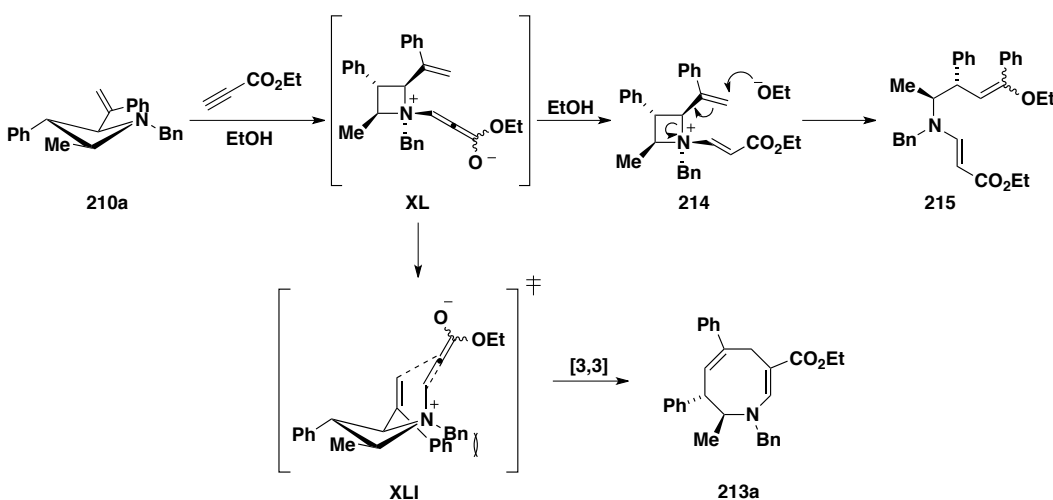

Scheme 1.66: Competitive formation of acyclic products in highly functionalized azetidines.

The formation of azocinone derivatives is also possible through the rhodium-catalyzed ring opening of 3-alkylideneazetidines (**216**, Scheme 1.67).⁶⁰ The ring expansion is hypothesized to occur via C-H activation of **216** to give **XLII**, followed by hydrometallation of the C-C double bond to give metallocyclopentanone **XLIII**. Rearrangement of **XLIII** to **XLIV** followed by reductive elimination would lead to the observed product **217**.

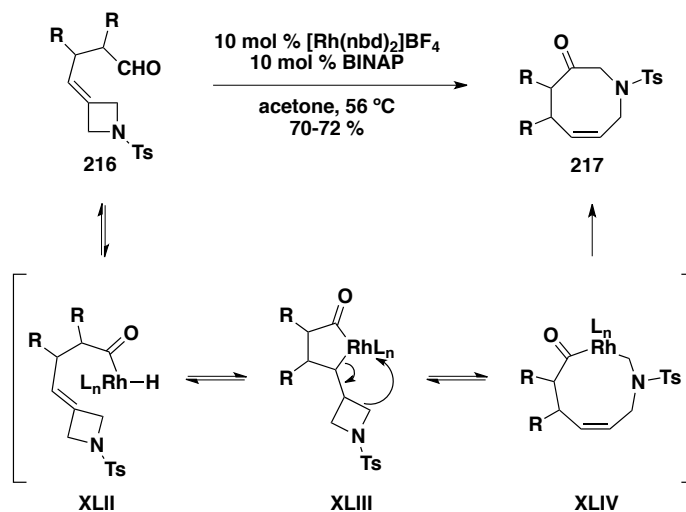

Scheme 1.67: Rhodium-catalyzed ring expansion of azetidines to azocinone derivatives.

In 2009, Ghorai and coworkers reported the enantioselective synthesis of 1,4-oxazepanes and 1,5-oxazocines *via* ring opening of azetidines with bromoalcohols (Scheme 1.68).⁶¹ This procedure, which took enantiopure *N*-tosyl azetidines **218** and activated them with $\text{Cu}(\text{OTf})_2$ in the presence of the alcohol, resulted in ring opening to the acyclic amine **219**. Subsequent addition of potassium hydroxide facilitated closure of the larger ring to generate diastereomers **220a** and **220b**.

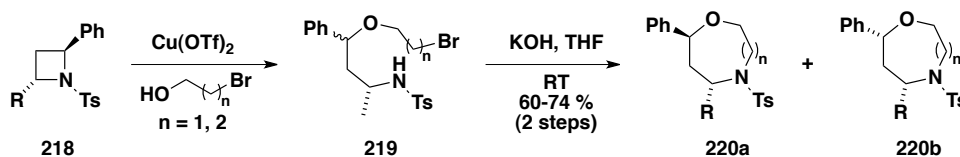

Scheme 1.68: Ring expansion of azetidines to 1,4-oxazepanes and 1,5-oxazocines.

With mono-substituted azetidines ($R = H$) it was found that the enantiomeric excess (ee) decreased during the reaction. The authors believe that this is due to partial racemization of the starting azetidines in the presence of copper triflate, in analogy to a process they had observed with aziridines. The 2,4-disubstituted substrates, however, remained at >99 % ee and without any observation of another diastereomer. This is because the necessary epimerization of the benzylic position for racemization to occur would lead to the substituents on the ring being *cis* to one another, which is less favourable (Figure 1.5).

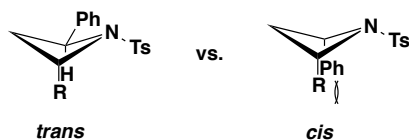
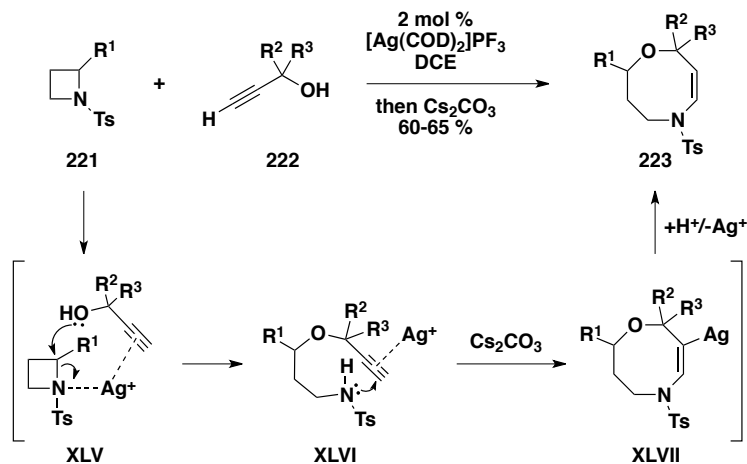

Figure 1.5: Comparison of steric interactions in *cis* and *trans*-2,4-disubstituted azetidines.

The Roy group has also reported a ring expansion involving Lewis acid activation of 2-substituted *N*-tosyl-azetidines to give hydrooxazocenes.⁶² This methodology utilizes Ag(I)-catalyzed dual activation of both azetidine **221** and propargylic alcohol **222**. This activation triggers a ring opening/closure cascade, which results in formation of 8-membered heterocycles **223** (Scheme 1.69).



Scheme 1.69: Formation of hydrooxazocenes from azetidines and propargyl alcohols.

The number of reports for successful ring expansion of azetidines to larger ring systems over the last few years has started to increase. This is most likely due to the ability to access a large array of enantiopure azetidines from readily available and affordable starting materials.

1.4.5. Application of Azetidines in Catalysis

With the recent development of methodologies to quickly synthesize azetidines in enantiomerically pure form, it is not surprising that their implementation as either ligands for metal-catalyzed reactions or as chiral auxiliaries in organocatalysis is increasing. The first examples of the successful application of azetidines as chiral ligands were reported in the 1990's and involved the borane reduction of aldehydes and ketones (Scheme 1.70).⁶³ The success in these cases is presumed to derive from the rigid framework of the oxaborolidines (**225**) as both acyclic and 5-membered ring analogues resulted in lower enantiomeric excesses.

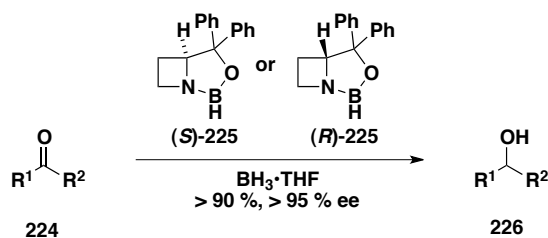

Scheme 1.70: Asymmetric reduction of aldehydes and ketones with oxaborolidines.

Along the same lines, the asymmetric alkylation of aldehydes with diethylzinc has also been examined using azetidines with alcohol substituents as bidentate chiral ligands (Scheme 1.71)^{64a-d, 26a, 64e} Over the last decade there have been several reports in which the transformation is both highly enantioselective and high yielding with a variety of differently substituted chiral azetidines (**229-237**).

Azetidines have also been used as ligands with palladium in Suzuki cross-coupling reactions,⁶⁵ and with rhodium for enantioselective cyclopropanation reactions.⁶⁶ The enantiocontrol observed in the cyclopropanation using azetidine-4-carboxylate-derived rhodium complexes (**242**, Scheme 1.72) is notable as it generally leads to the preferential formation of *cis*-cyclopropanes, which is in contrast to the preference for the *trans*-cyclopropanes observed with other similar 5-membered ring analogues **243**.

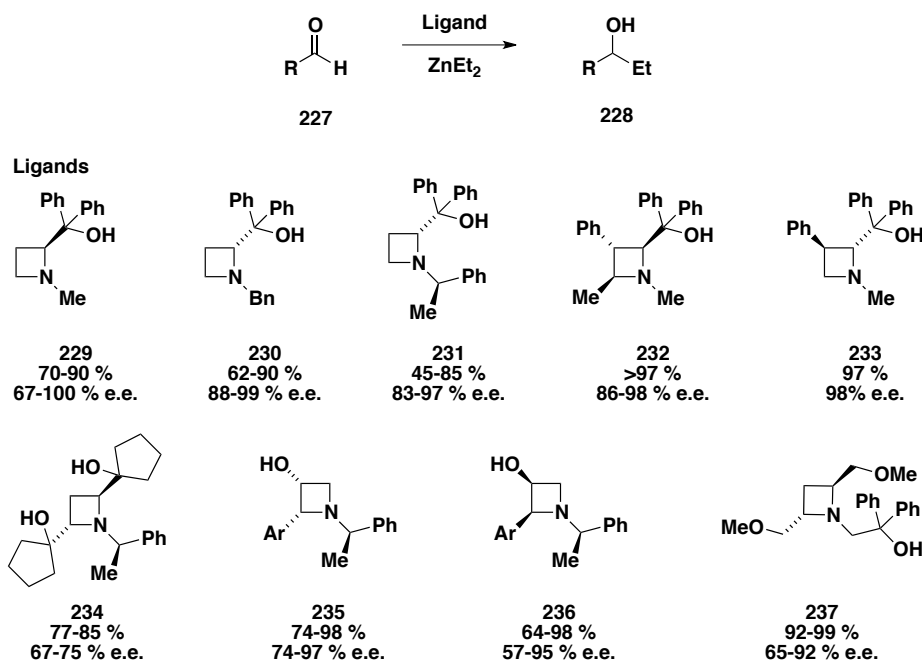

Scheme 1.71: Asymmetric alkylation of aldehydes with diethyl zinc and azetidine-based catalysts.

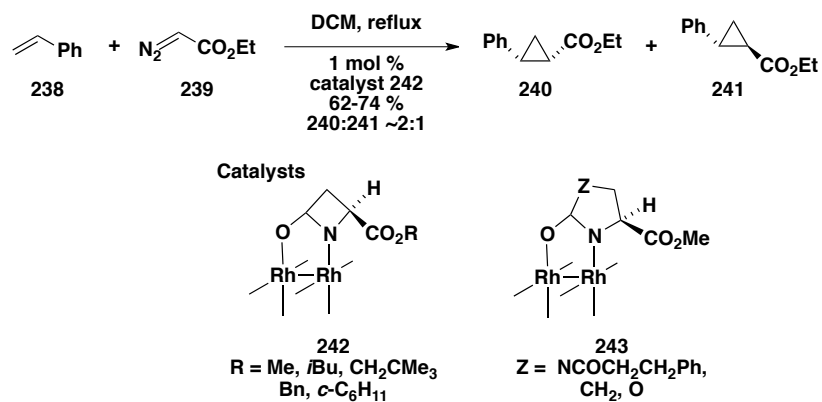

Scheme 1.72: Use of azetidines as ligands on rhodium for enantioselective cyclopropanations.

The success of proline and its derivatives in organocatalysis is well documented in the literature.⁶⁷ Not surprisingly, the application of azetidines as organocatalysts for *in situ* formation of chiral iminium or enamine species has also been successful. In 2006, Greck and coworkers reported the asymmetric α -amidation of ketones with dibenzyl azodicarboxylate (DBAD) using L-azetidine 2-carboxylic acid (**9**) as the catalyst (Scheme 1.73).⁶⁸ It should be noted that the authors also performed the reactions using L-proline as the catalyst but the yields and enantiomeric excesses were lower than those observed with **9**.

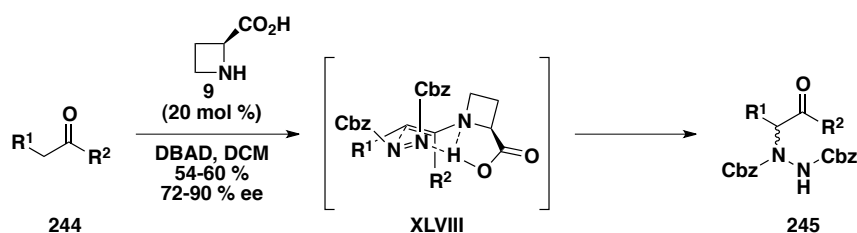

Scheme 1.73: Use of L-azetidine-2-carboxylic acid for the asymmetric α -amidation of ketones.

The use of azetidinic 1,2-diamines as organocatalysts for asymmetric Michael additions has also been reported recently.⁶⁹ In this paper, the authors screened a variety of thioureas derived from differently substituted primary and secondary α -aminomethyl-azetidines **251** and 3-aminopyrrolidines **252** for the addition of diethylmalonate (**247**) to β -nitrostyrene (**246**, Scheme 1.74). They found that only catalyst **253** showed high catalytic activity and after optimization led to the formation of the Michael adduct **249** in 77 % yield and an e.r. of 68:32 (*S*:*R*).

Interestingly, when diethyl malonate **247** was replaced with acetoacetone **248** the absolute configuration of the Michael adduct (**250**) was reversed (e.r. = 12:88 (*S*:*R*)). The authors believe this reversal is due to the difference in pK_a of the two nucleophiles. Scheme 1.75 shows the proposed transition state for the reaction with diethylmalonate, which has a pK_a of 13. In this case, hydrogen bonding between the nitro group and the thiourea along with concomitant

deprotonation of the enol form of diethylmalonate by the proximate tertiary amine leads to attack on the *Si* face of the nitrostyrene and generation of (*S*)-**249** as the major enantiomer.

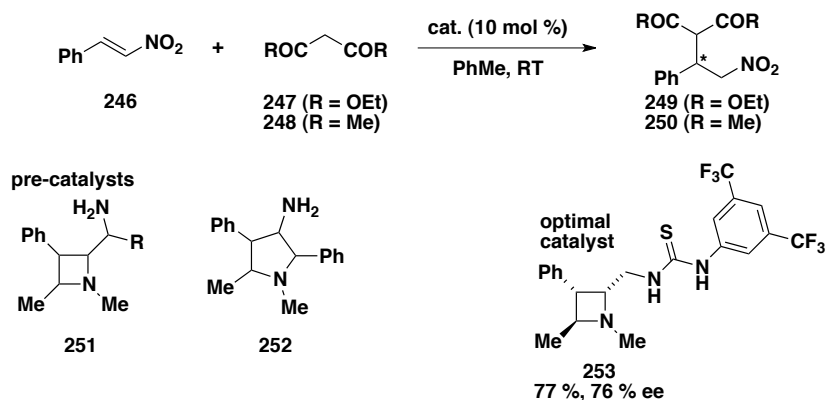

Scheme 1.74: Asymmetric Michael additions with azetidine-based catalysts.

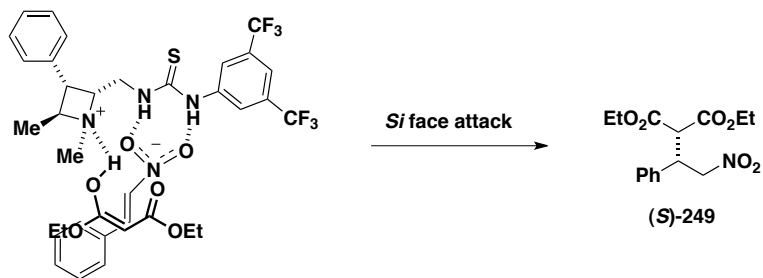

Scheme 1.75: Proposed transition state for Michael addition with diethylmalonate.

The reaction with acetoacetone **248** ($pK_a = 9$), on the other hand, would lead to attack on the *Re* face. This is due to the more facile deprotonation of **248** resulting in the formation of an ammonium species, which can then hydrogen bond with the nitro group. If the enolate then coordinates to the thiourea, the result is the transition state shown in Scheme 1.76, which illustrates how (*R*)-**250** is formed preferentially.

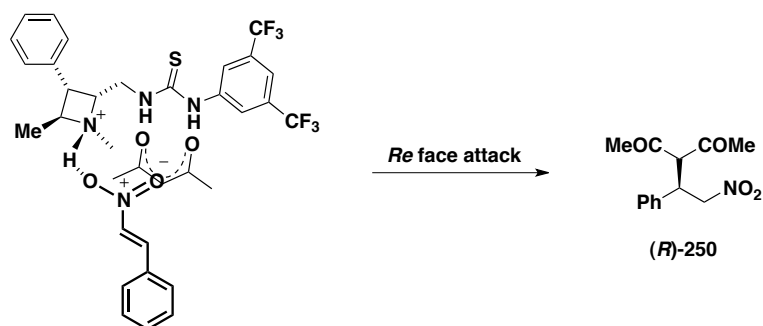

Scheme 1.76: Proposed transition state for Michael addition with acetoacetone.

Overall, the advancements made in the chemistry of azetidines in the last few decades say a great deal about the potential of these small molecules. The above summary has highlighted some of the most versatile methods for the generation of both simple and highly functionalized azetidines, as well as some of the new methods that hold potential to be so in the future. Their application in the synthesis of a wide range of molecules, from enantiopure acyclic amines to ordinarily challenging medium-sized heterocycles, shows that they are of great asset in multiple areas of chemistry.

1.5. References

1. (a) De Kimpe, N., *Comprehensive Heterocyclic Chemistry II* **1996**, *1B*, 507-589; (b) Brandi, A.; Cicchi, S.; Cordero, F. M., *Chem. Rev.* **2008**, *108*, 3988-4035; (c) Singh, G. S., D'hooghe, M., De Kimpe, N., *Comprehensive Heterocyclic Chemistry III* **2008**, *2*, 3-110; (d) Couty, F.; Evano, G., *Synlett* **2009**, 3053-3064.
2. Moore, J. A., Ayers, R. S., *Small Ring Heterocycles, Pt. 2: Azetidines, β -Lactams, Diazetidines, and Diaziridines*. New York, 1983; Vol. 42, p 656.
3. Anet, F. A. L., *J. Am. Chem. Soc.* **1985**, *107*, 4335-4335.

4. (a) Benson, S. W.; Cruickshank, F. R.; Golden, D. M.; Haugen, G. R.; O'Neal, H. E.; Rodgers, A. S.; Shaw, R.; Walsh, R., *Chem. Rev.* **1969**, *69*, 279-324; (b) Dudev, T.; Lim, C., *J. Am. Chem. Soc.* **1998**, *120*, 4450-4458; (c) Bach, R. D.; Dmitrenko, O., *J. Org. Chem.* **2002**, *67*, 3884-3896.

5. Padwa, A., *Comprehensive Heterocyclic Chemistry III* **2008**, *1*, 1-105.

6. Silverstein, R. M., Webster, Francis X. , *Spectrometric Identification of Organic Compounds*. 6 ed.; John Wiley & Sons: New York, 1997.

7. Laguerre, M.; Boyer, C.; Leger, J.-M.; Carpy, A., *Can. J. Chem.* **1989**, *67*, 1514-1522.

8. Fowden, L., *Nature* **1955**, *176*, 347-348.

9. Couty, F.; Evano, G., *Org. Prep. Proced. Int.* **2006**, *38*, 427-465.

10. (a) Shioiri, T.; Hamada, Y.; Matsuura, F., *Tetrahedron* **1995**, *51*, 3939-3958; (b) Miyakoshi, K.; Oshita, J.; Kitahara, T., *Tetrahedron* **2001**, *57*, 3355-3360; (c) Singh, S.; Crossley, G.; Ghosal, S.; Lefievre, Y.; Pennington, M. W., *Tetrahedron Lett.* **2005**, *46*, 1419-1421.

11. (a) Knapp, S.; Dong, Y., *Tetrahedron Lett.* **1997**, *38*, 3813-3816; (b) Beauhaire, J.; Ducrot, P.-H., *Synth. Commun.* **1998**, *28*, 2443-2456; (c) Liu, D.-G.; Lin, G.-Q., *Tetrahedron Lett.* **1999**, *40*, 337-340; (d) Ohshita, K.; Ishiyama, H.; Takahashi, Y.; Ito, J.; Mikami, Y.; Kobayashi, J. i., *Biorg. Med. Chem.* **2007**, *15*, 4910-4916; (e) Raghavan, S.; Krishnaiah, V., *J. Org. Chem.* **2009**, *75*, 748-761.

12. Isono, K.; Asahi, K.; Suzuki, S., *J. Am. Chem. Soc.* **1969**, *91*, 7490-7505.

13. Di, Y.-T.; He, H.-P.; Wang, Y.-S.; Li, L.-B.; Lu, Y.; Gong, J.-B.; Fang, X.; Kong, N.-C.; Li, S.-L.; Zhu, H.-J.; Hao, X.-J., *Org. Lett.* **2007**, *9*, 1355-1358.
14. Wasserman, H. H.; Lipshutz, B. H.; Tremper, A. W.; Wu, J. S., *J. Org. Chem.* **1981**, *46*, 2991-2999.
15. Burkett, B. A.; Ting, S. Z.; Gan, G. C. S.; Chai, C. L. L., *Tetrahedron Lett.* **2009**, *50*, 6590-6592.
16. Enders, D.; Gries, J., *Synthesis* **2005**, 3508-3516.
17. Das, B.; Balasubramanyam, P.; Veeranjanyulu, B.; Chinna Reddy, G., *J. Org. Chem.* **2009**, *74*, 9505-9508.
18. Yadav, L. D. S.; Srivastava, V. P.; Patel, R., *Tetrahedron Lett.* **2008**, *49*, 5652-5654.
19. Concellón, J. M.; Bernad, P. L.; Pérez-Andrés, J. A., *Tetrahedron Lett.* **2000**, *41*, 1231-1234.
20. Robin, S.; Rousseau, G., *Eur. J. Org. Chem.* **2000**, 3007-3011.
21. (a) Pannecoucke, X.; Outurquin, F.; Paulmier, C., *Eur. J. Org. Chem.* **2002**, 995-1006; (b) Franck, X.; Leleu, S.; Outurquin, F., *Tetrahedron Lett.* **2010**, *51*, 4437-4440.
22. Pradhan, T. K.; Krishnan, K. S.; Vasse, J.-L.; Szymoniak, J., *Org. Lett.* **2011**, *13*, 1793-1795.

23. De Nicola, A.; Einhorn, C.; Einhorn, J.; Luche, J. L., *J. Chem. Soc., Chem. Commun.* **1994**, 879-880.
24. Blythin, D. J.; Green, M. J.; Lauzon, M. J. R.; Shue, H.-J., *J. Org. Chem.* **1994**, *59*, 6098-6100.
25. Agami, C.; Couty, F.; Evano, G., *Tetrahedron: Asymmetry* **2002**, *13*, 297-302.
26. (a) Couty, F.; Prim, D., *Tetrahedron: Asymmetry* **2002**, *13*, 2619-2624; (b) Couty, F.; Durrat, F.; Prim, D., *Tetrahedron Lett.* **2003**, *44*, 5209-5212; (c) Couty, F.; Evano, G.; Rabasso, N., *Tetrahedron: Asymmetry* **2003**, *14*, 2407-2412.
27. Wessig, P.; Schwarz, J., *Helv. Chim. Acta* **1998**, *81*, 1803-1814.
28. Singh, G. S., *Tetrahedron* **2003**, *59*, 7631-7649.
29. Rasmussen, J. K.; Hassner, A., *Chem. Rev.* **1976**, *76*, 389-408.
30. Uyehara, T.; Yuuki, M.; Masaki, H.; Matsumoto, M.; Ueno, M.; Sato, T., *Chem. Lett.* **1995**, 789-790.
31. Zhao, G.-L.; Huang, J.-W.; Shi, M., *Org. Lett.* **2003**, *5*, 4737-4739.
32. Denis, J.-B.; Masson, G.; Retailleau, P.; Zhu, J., *Angew. Chem. Int. Ed.* **2011**, *50*, 5356-5360.
33. Ye, Y.; Wang, H.; Fan, R., *Org. Lett.* **2010**, *12*, 2802-2805.

34. Domostoj, M.; Ungureanu, I.; Schoenfelder, A.; Klotz, P.; Mann, A., *Tetrahedron Lett.* **2006**, *47*, 2205-2208.
35. Bertolini, F.; Crotti, S.; Bussolo, V. D.; Macchia, F.; Pineschi, M., *J. Org. Chem.* **2008**, *73*, 8998-9007.
36. Akiyama, T.; Daidouji, K.; Fuchibe, K., *Org. Lett.* **2003**, *5*, 3691-3693.
37. Vargas-Sanchez, M.; Lakhdar, S.; Couty, F.; Evano, G., *Org. Lett.* **2006**, *8*, 5501-5504.
38. (a) Campbell, J., *J. Org. Chem.* **1957**, *22*, 1259-1260; (b) Olofson, R. A.; Martz, J. T.; Senet, J. P.; Piteau, M.; Malfroot, T., *J. Org. Chem.* **1984**, *49*, 2081-2082.
39. (a) Couty, F.; Durrat, F.; Evano, G., *Targets in Heterocyclic Systems* **2005**, *9*, 186-210; (b) Couty, F.; David, O.; Durrat, F.; Evano, G.; Lakhdar, S.; Marrot, J.; Vargas-Sanchez, M., *Eur. J. Org. Chem.* **2006**, *2006*, 3479-3490; (c) Couty, F.; David, O.; Drouillat, B., *Tetrahedron Lett.* **2007**, *48*, 9180-9184; (d) Couty, F.; David, O.; Durrat, F., *Tetrahedron Lett.* **2007**, *48*, 1027-1031.
40. Leng, D.-H.; Wang, D.-X.; Pan, J.; Huang, Z.-T.; Wang, M.-X., *J. Org. Chem.* **2009**, *74*, 6077-6082.
41. Alex, A.; Larmanjat, B.; Marrot, J.; Couty, F.; David, O., *Chem. Commun.* **2007**, 2500-2502.
42. Couty, F.; David, O.; Larmanjat, B.; Marrot, J., *J. Org. Chem.* **2007**, *72*, 1058-1061.

43. Masuda, T.; Chinone, A.; Ohta, M., *Bull. Chem. Soc. Jap.* **1970**, *43*, 3287-3288.
44. Alcaide, B.; Almendros, P.; Aragoncillo, C.; Salgado, N. R., *J. Org. Chem.* **1999**, *64*, 9596-9604.
45. Outurquin, F.; Pannecoucke, X.; Berthe, B.; Paulmier, C., *Eur. J. Org. Chem.* **2002**, *2002*, 1007-1014.
46. Durrat, F.; Sanchez, M. V.; Couty, F.; Evano, G.; Marrot, J., *Eur. J. Org. Chem.* **2008**, 3286-3297.
47. Couty, F.; Kletsii, M., *Journal of Molecular Structure: THEOCHEM* **2009**, *908*, 26-30.
48. Dekeukeleire, S.; D'Hooghe, M.; Tornroos, K. W.; De Kimpe, N., *J. Org. Chem.* **2010**, *75*, 5934-5940.
49. Drouillat, B.; Couty, F.; David, O.; Evano, G.; Marrot, J., *Synlett* **2008**, *2008*, 1345,1348.
50. Vargas-Sanchez, M.; Couty, F.; Evano, G.; Prim, D.; Marrot, J., *Org. Lett.* **2005**, *7*, 5861-5864.
51. Vanecko, J. A.; West, F. G., *Org. Lett.* **2005**, *7*, 2949-2952.
52. West, F. G.; Glaeske, K. W.; Naidu, B. N., *Synthesis* **1993**, 977-980.
53. Bott, T. M.; Vanecko, J. A.; West, F. G., *J. Org. Chem.* **2009**, *74*, 2832-2836.

54. Gnass, Y.; Glorius, F., *Synthesis* **2006**, 2006, 1899-1930.
55. Couty, F.; Drouillat, B.; Lemee, F., *Eur. J. Org. Chem.* **2011**, 794-801.
56. Van Brabant, W.; Van Landeghem, R.; De Kimpe, N., *Org. Lett.* **2006**, 8, 1105-1108.
57. (a) Ghorai, M. K.; Das, K.; Kumar, A.; Das, A., *Tetrahedron Lett.* **2006**, 47, 5393-5397; (b) Ghorai, M. K.; Das, K.; Kumar, A., *Tetrahedron Lett.* **2007**, 48, 4373-4377; (c) Ghorai, M. K.; Das, K.; Kumar, A., *Tetrahedron Lett.* **2009**, 50, 1105-1109.
58. Anslyn, E. V. D., Dennis A., *Modern Physical Organic Chemistry*. University Science: Sausalito, 2006.
59. (a) Couty, F.; Durrat, F.; Evano, G.; Marrot, J., *Eur. J. Org. Chem.* **2006**, 4214-4223; (b) Drouillat, B.; Couty, F.; Razafimahaleo, V., *Synlett* **2009**, 3182-3186.
60. Crépin, D.; Dawick, J.; Aïssa, C., *Angew. Chem. Int. Ed.* **2010**, 49, 620-623.
61. Ghorai, M. K.; Shukla, D.; Das, K., *J. Org. Chem.* **2009**, 74, 7013-7022.
62. Bera, M.; Roy, S., *J. Org. Chem.* **2009**, 74, 8814-8817.
63. (a) Behnen, W.; Dauelsberg, C.; Wallbaum, S.; Martens, J., *Synth. Commun.* **1992**, 22, 2143-2153; (b) Rao, P. D.; Chen, C. H.; Liao, C. C., *Chem. Commun.* **1998**, 155-156.

64. (a) Behnen, W.; Mehler, T.; Martens, J., *Tetrahedron: Asymmetry* **1993**, *4*, 1413-1416; (b) Shi, M.; Jiang, J.-K., *Tetrahedron: Asymmetry* **1999**, *10*, 1673-1679; (c) Wilken, J.; Erny, S.; Wassmann, S.; Martens, J. r., *Tetrahedron: Asymmetry* **2000**, *11*, 2143-2148; (d) Hermsen, P. J.; Cremers, J. G. O.; Thijs, L.; Zwanenburg, B., *Tetrahedron Lett.* **2001**, *42*, 4243-4245; (e) Zhang, Z.; Li, M.; Zi, G., *Chirality* **2007**, *19*, 802-808.
65. Keller, L.; Sanchez, M. V.; Prim, D.; Couty, F.; Evano, G.; Marrot, J., *J. Organomet. Chem.* **2005**, *690*, 2306-2311.
66. Doyle, M. P.; Davies, S. B.; Hu, W., *Chem. Commun.* **2000**, 867-868.
67. (a) Kotsuki, H.; Ikishima, H.; Okuyama, A., *Heterocycles* **2008**, *75*, 757-797; (b) Kotsuki, H.; Ikishima, H.; Okuyama, A., *Heterocycles* **2008**, *75*, 493-529.
68. Thomassigny, C.; Prim, D.; Greck, C., *Tetrahedron Lett.* **2006**, *47*, 1117-1119.
69. Menguy, L.; Couty, F., *Tetrahedron: Asymmetry* **2010**, *21*, 2385-2389.

Chapter 2

The Ring Expansion of Azetidines to Pyrrolidines via the Stevens Rearrangement of Azetidinium Ylides

2.1. Introduction

The pyrrolidine skeleton is prevalent in many areas of chemistry. There are numerous naturally occurring alkaloids, both simple and complex, that contain the pyrrolidine framework (Figure 2.1) and many of these have been found to have biological activity.¹ Proline, a non-essential amino acid, and nicotine, a stimulant found in tobacco, are some of the simplest and well-known pyrrolidines.² The more substituted pyrrolidines preussin³ and anisomycin⁴ have been found to display antifungal activity⁵ while broussonetine B and related analogs are potent glycosidase inhibitors.⁶

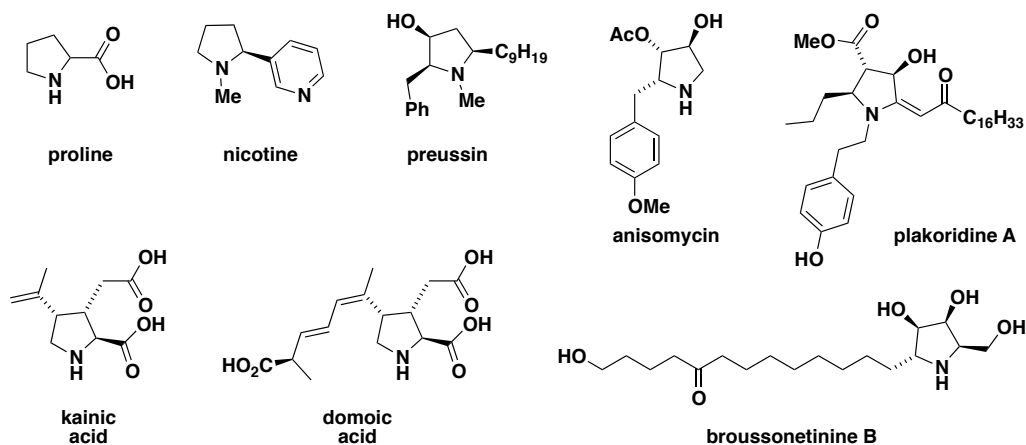

Figure 2.1: Selection of pyrrolidine natural products.

The kainoid family of alkaloids is another example of simple pyrrolidines that have generated a great interest due to their potent neuroexcitatory activity.⁷

Kainic acid, the parent molecule in this family, as well as domoic acid, a close relative, has been the target of many synthetic efforts.⁸

Aside from their potential pharmacological uses, pyrrolidine-derived compounds have significant importance in the area of organocatalysis. Enantiopure proline and proline-derived organocatalysts such as prolinols, proline tetrazoles and prolinamides (Figure 2.2) are used to impart asymmetry in a large variety of reactions.⁹ The most common uses of these organocatalysts are the formation of either a chiral iminium species (**I**),^{9a} which has been used in Diels-Alder (eq 1)¹⁰ and [3+2]-cycloadditions (eq 2),¹¹ as well as Knoevenagel condensations (eq 3),¹² or a chiral enamine species,^{9c} often used in asymmetric Michael (eq 4),¹³ Aldol (eq 5)¹⁴ or Mannich reactions (eq 6).¹⁵

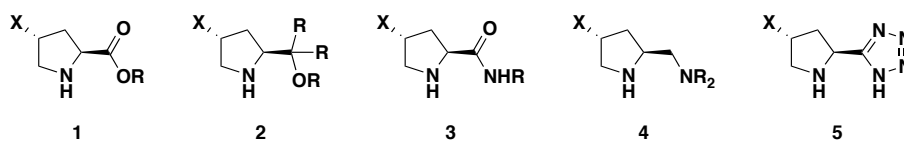
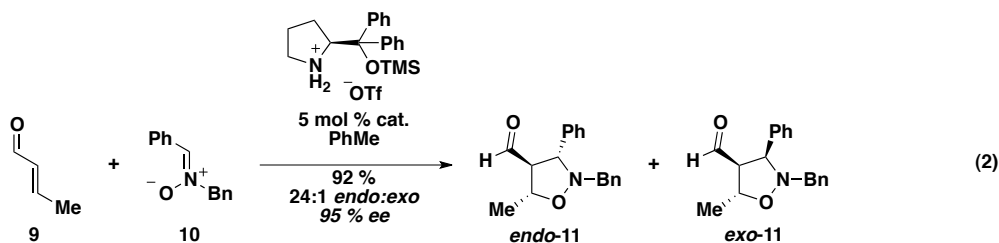
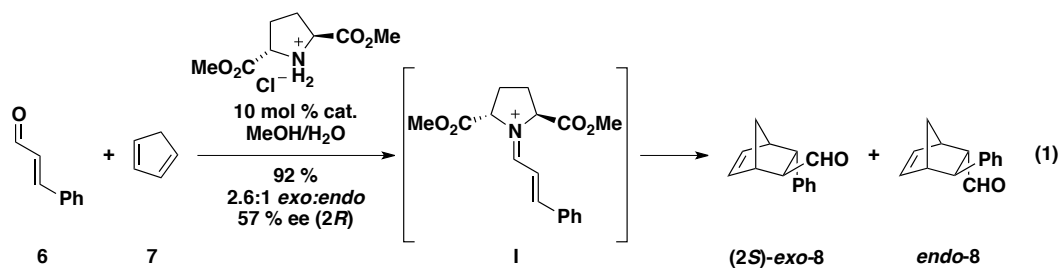
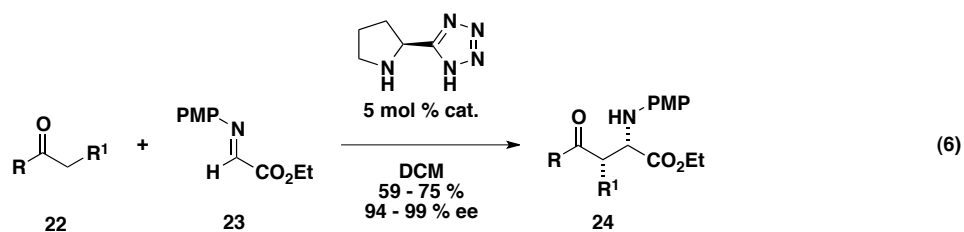
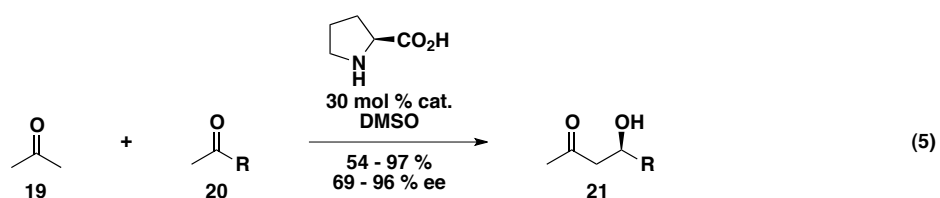
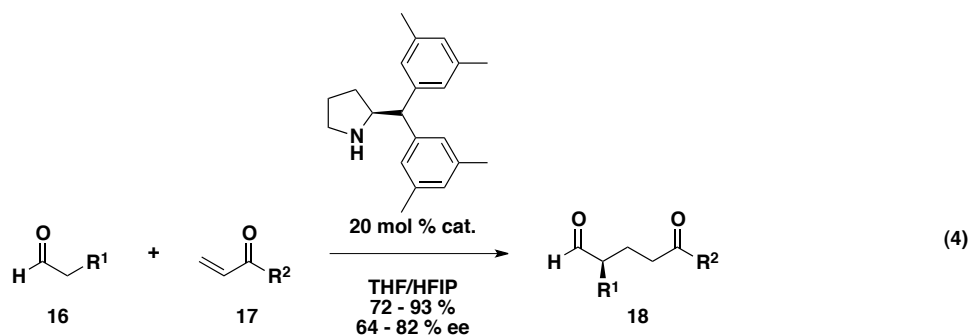
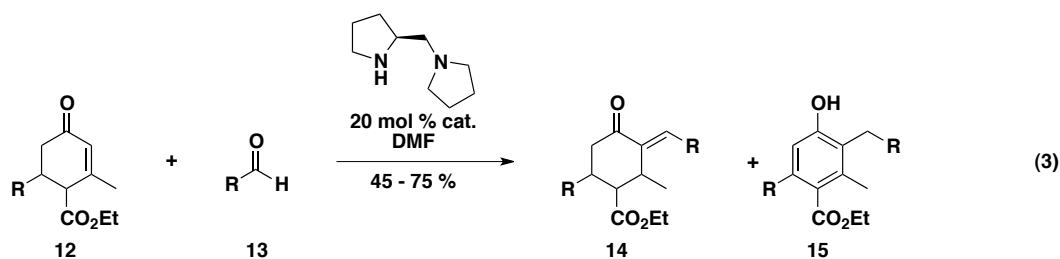

Figure 2.2: Proline-derived organocatalysts.





2.2. Synthetic Efforts to the Pyrrolidine Core

With the above-mentioned opportunities for molecules with a pyrrolidine skeleton, it is not surprising that there has been a great deal of interest in developing methodologies for their synthesis. There are several recent reviews on the subject,¹⁶ but a brief highlight of some of the more interesting methods will be presented below.

2.2.1. Intramolecular Aminopalladation

The use of palladium catalysis for the formation of carbon-nitrogen bonds is well established in the literature.^{17, 5} One of the reasons this methodology is so appealing is the ability to perform secondary transformations on the 2-aminoalkyl-palladium intermediate (**IV**) after the initial ring closure (Figure 2.3). For many of these reactions the exact mechanism is not known, however, two plausible pathways are possible. Pathway **a** begins with direct coordination of palladium with the alkene followed by nucleophilic attack by nitrogen. Alternatively, in pathway **b**, the reaction starts with coordination of the palladium to both the nitrogen and the alkene followed by alkene insertion.

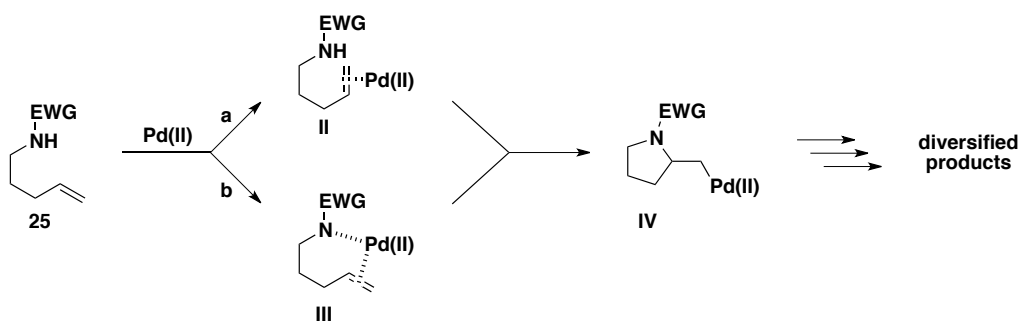
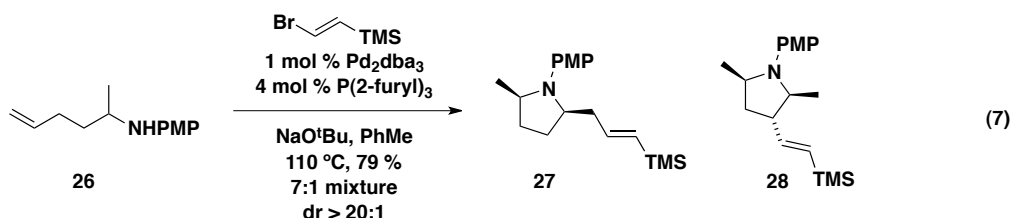
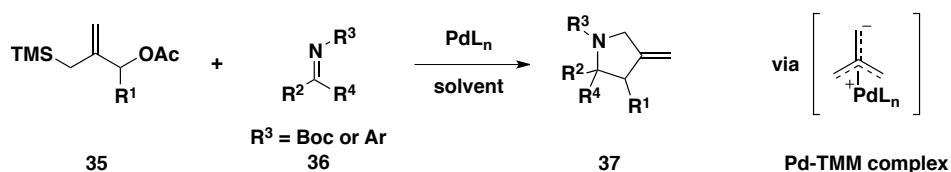

Figure 2.3: Possible mechanistic pathways of aminopalladation.

The intermediate 2-aminoalkylpalladium species (**IV**) can subsequently undergo several different types of reactions after its formation depending on the conditions employed. Some examples are vinylation (eq 7),¹⁷ arylation (eq 8),¹⁸ β -hydride elimination (eq 9),¹⁹ or carbonylation (eq 10).²⁰



complex, and an imine.²² The Trost group has contributed a great deal to the literature on the use of palladium-trimethylenemethane (Pd-TMM) [3+2]-cycloadditions. Using 3-acetoxy-2-trimethylsilylmethyl-1-propene (**35**) as a TMM precursor and an aromatic or Boc-protected imine (**36**) they were able to obtain the desired pyrrolidine products (**37**) in good yields (Scheme 2.2).²²⁻²³



Scheme 2.2: Generation of pyrrolidines via [3+2]-cycloaddition with imines.

2.2.3. Ring Expansion of Azetidines

The chemistry of azetidines and azetidinium ylides has been explored in great detail in Chapter 1. One interesting feature of these small, strained molecules is their ability to undergo rapid ring expansion to pyrrolidines when properly functionalized and treated under the right reaction conditions.²⁴ The most commonly observed expansions proceed by the intramolecular displacement of a leaving group on the azetidine (**39**) to form either the strained aza-housane intermediate **V** or aziridine intermediate **VI**, followed by nucleophilic ring opening to give the thermodynamic product (Scheme 2.3).

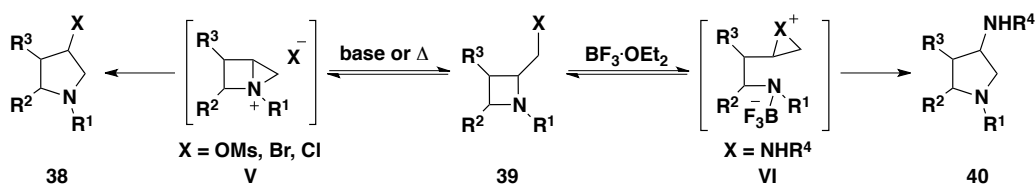

Scheme 2.3: Intramolecular ring-expansion of azetidines to pyrrolidines.

In 2005, West and Vanecko reported a different ring expansion approach to the pyrrolidine system that involved the *in situ* formation of an azetidinium ylide

2.3. Background

The Stevens rearrangement, or [1,2]-shift, is a highly efficient reaction for the formation of nitrogen-containing compounds.²⁷ The first example, reported by Stevens and coworkers in 1928,²⁸ was observed when ammonium salt **46** was treated with aqueous base (Scheme 2.6). The resulting tertiary amine (**47**), the product of a [1,2]-shift of the benzyl group from nitrogen to carbon, was isolated in excellent yield.

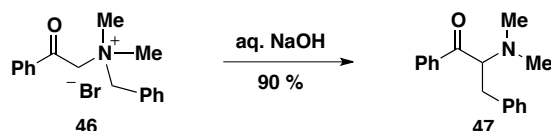

Scheme 2.6: First reported example of the Stevens rearrangement.

The mechanism of the rearrangement was not established until several years after Stevens' initial work. A great deal of debate arose in the literature over the potential of this rearrangement to occur via an ion pair mechanism, a concerted [1,2]-shift mechanism or a radical pair mechanism. Today it is generally accepted that the rearrangement occurs by the radical pair mechanism, which involves generation of an ammonium ylide (**IX**) followed by homolytic cleavage of the carbon-nitrogen bond that affords the most stable radical pair (**X**). Facile recombination of this radical pair gives the [1,2]-shift product **47** (Scheme 2.7).

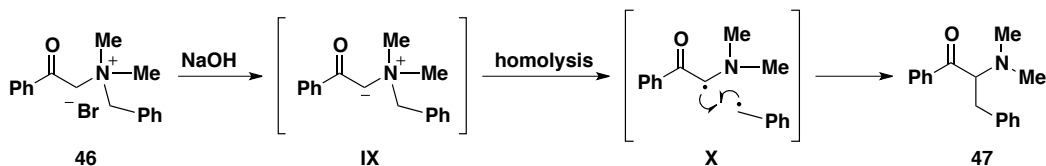

Scheme 2.7: Radical pair mechanism.

2.3.1. Methods for Ylide Formation

The initial methods used to generate ammonium ylides for the Stevens rearrangement involved treating quaternary ammonium salts with a strong base. Although this method works well in some cases (see Scheme 2.6) there are several ways in which a substrate can undergo unwanted side-reactions when subjected to these conditions. Common problems include competitive deprotonation, giving rise to more than one ylide intermediate (eq 11), Hoffmann elimination, resulting in the formation of a tertiary amine and an alkene (eq 12), and Sommelet-Hauser [2,3]-rearrangements, resulting in *ortho*-alkylation of an adjacent aromatic ring (eq 13).

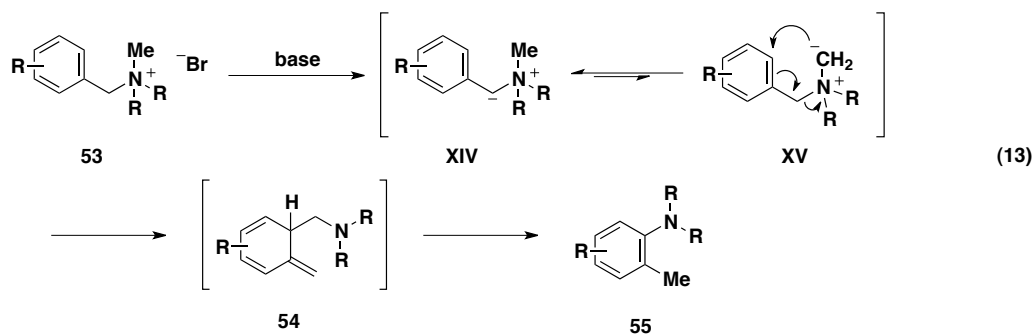
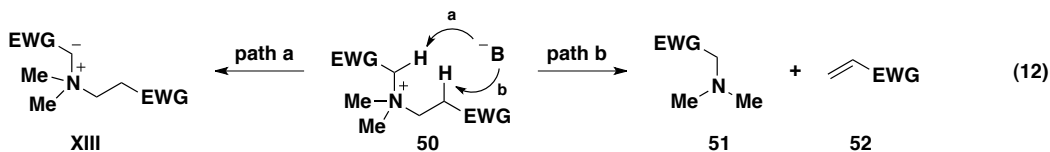
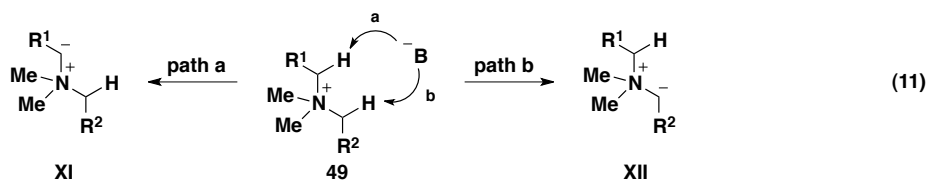

2.3.2. The Desilylation Method for Ylide Formation

To circumvent some of the problems associated with the use of strong bases, several more versatile methods to generate the ylide intermediate were developed. Both the Vedejs²⁹ and Sato³⁰ groups reported the desilylation of trialkylsilyl-substituted ammonium salts for regioselective ylide generation. The Sato group was able to cleave the carbon-silicon bond of triphenylsilylmethylammonium salts using lithium aluminum hydride (eq 14) while the Vedejs group utilized cesium fluoride, an excellent silaphile, for regioselective ylide formation from trimethylsilyl ammonium salts (eq 15).

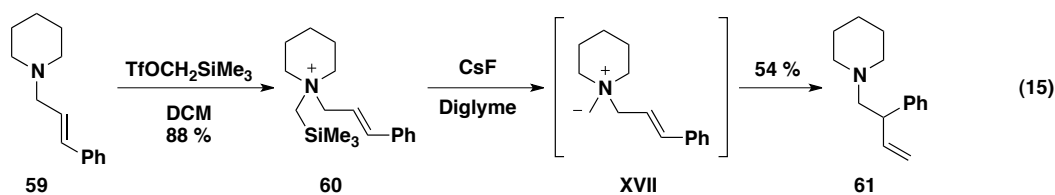
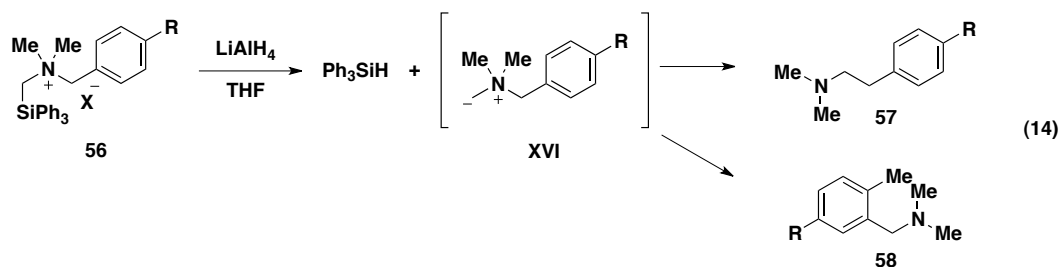

2.3.3. The Use of Carbenes in Ylide Generation

Stevens was the first to report the generation of an ammonium ylide by reaction of a tertiary amine with a carbene.³¹ This method involved the thermal decomposition of diazocarbonyl compound **62**, generating a carbene (**XVII**), which underwent nucleophilic attack by the tertiary amine to give the ylide

intermediate (**XIX**). Subsequent [1,2]-shift led to formation of the product, amino-fluorene **63**, in 30 % yield (Scheme 2.8).

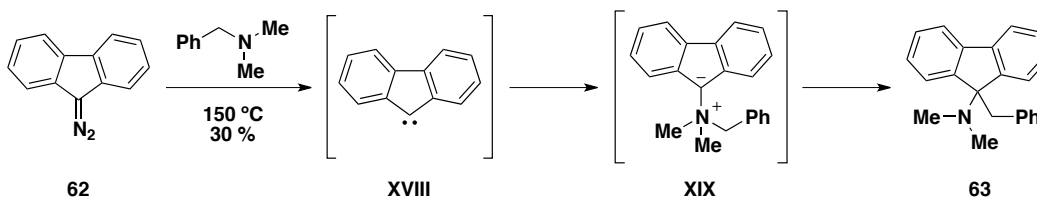

Scheme 2.8: First example of ammonium ylide formation using carbenes.

Although the above example was successful in forming the [1,2]-shift product, the widespread application of *in situ* thermal diazo decomposition had several shortcomings, namely poor yields and the formation of multiple unwanted side products, which hindered its use in synthesis. This is caused by the fact that free carbenes are high-energy reactive intermediates that will typically react quickly and indiscriminately with whatever potential partner that they encounter. The use of photochemical diazo decomposition has been successful in a handful of cases, but unfortunately this method also suffers from many of the same problems as noted above.³²

The discovery of diazo decomposition in the presence of metal catalysts was the real breakthrough in the evolution of the Stevens rearrangement. The addition of catalytic copper or rhodium salts allowed for the formation of an intermediate metalcarbene species that retains the electrophilic character of a free carbene, but with substantially attenuated reactivity and greater selectivity than that observed in thermal or photochemical processes. The catalytic cycle for ylide formation is shown in Figure 2.4. The metal catalyst initially coordinates with diazocarbonyl compound **64** to give intermediate **XX**, followed by loss of nitrogen gas to give metalcarbene intermediate **XXI**. Nucleophilic attack on the metalcarbene by amine **65** generates the metal-stabilized ylide, **XXII**, which can go on to subsequent transformations as is or after dissociation of the transition metal catalysts to give the free ylide, **XXIII**.

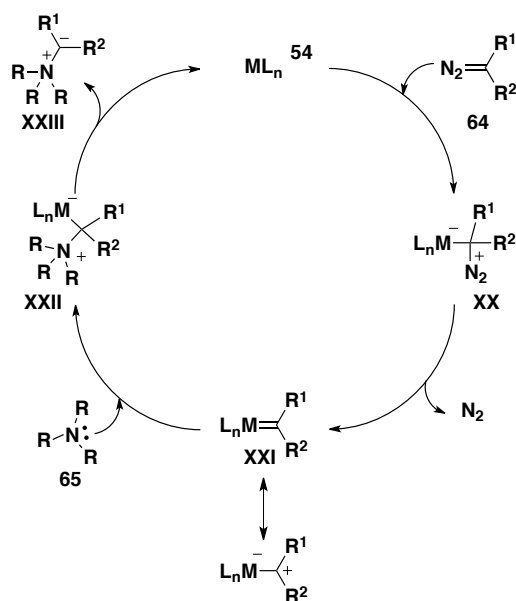
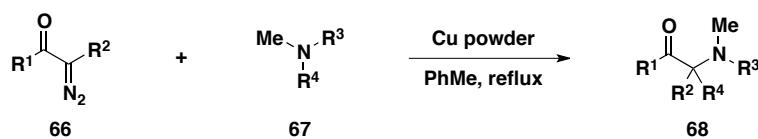

Figure 2.4: Catalytic cycle for the formation of ammonium ylides from metallocarbenes.

2.4. Trends in Migratory Selectivity in the Stevens [1,2]-Shift

As previously described, the mechanism of the Stevens rearrangement occurs by the homolysis of a carbon-nitrogen bond to give a biradical intermediate (Scheme 2.7). In general, the carbon-nitrogen bond that breaks is the one that provides the most stability in the newly formed radical centers. Our group has previously investigated the migratory preferences of several different substituents and some general trends that have been observed will be described below.

In 1993, West and Naidu reported the one-step synthesis of α -aminocarbonyl compounds (**68**) from tertiary amines and diazocarbonyl compounds (Table 2.1).³³ During their investigations they found that both phenyl and carboethoxy substituents proved effective in supporting the [1,2]-shift. These results are consistent with the radical pair mechanistic rationale, as both of these groups are capable of stabilizing a radical centre on the adjacent carbon through conjugation. When given the choice between phenyl- or carboethoxy-migration, however, phenyl migration occurred in all cases (entries 5 and 8). This is presumably due to the better radical stabilizing ability of the phenyl substituent.³⁴



Entry	R ¹	R ²	R ³	R ⁴	Yield (%)
1	OEt	H	Me	CH ₂ Ph	63
2	OEt	H	Me	CH ₂ CO ₂ Et	35
3	Ph	H	Me	CH ₂ Ph	70
4	Ph	H	Me	CH ₂ CO ₂ Et	26
5	Ph	H	CH ₂ CO ₂ Et	CH ₂ Ph	70
6	OEt	CO ₂ Et	Me	CH ₂ Ph	97
7	OEt	CO ₂ Et	Me	CH ₂ CO ₂ Et	90
8	OEt	CO ₂ Et	CH ₂ CO ₂ Et	CH ₂ Ph	92

Table 2.1: Substituent migration in [1,2]-shift of acyclic ylides.

That same year West and Naidu also published a paper on the synthesis of 2-piperidones (**70**) via intramolecular Stevens rearrangement of amine-tethered diazoketone substrates (**69**).³⁵ This paper also demonstrated the migrating ability of aryl- and carboethoxy substituents but, more interestingly, it gave insight into the effect of adding substituents to the aromatic-ring. In all cases, adding a substituent to the aromatic ring diminished the yield of the desired product and resulted in the formation of homodimeric biaryl products **71** (Table 2.2). The observation of **71** provides evidence for the proposed mechanism of the rearrangement, as it would be hard to explain its formation by any mechanistic pathways other than the radical pair one.

Another interesting observation reported by West and Naidu occurred during their work towards the synthesis of morpholin-2-ones in which they used diazoesters containing no conjugated stabilizing groups on nitrogen (Scheme 2.9).³⁶ Compound **72**, having an isopropyl group on nitrogen, gave none of the desired product (**73**) under standard reaction conditions. Treating compound **74** to the same reaction conditions, however, resulted in the desired Stevens rearrangement product **75**, albeit in low yield. The observation of [1,2]-shift

product formation with the *tert*-butyl group but not with the isopropyl group suggests that the minimum stability for carbon-nitrogen bond homolysis in this unstrained ylide lies somewhere between these two groups.

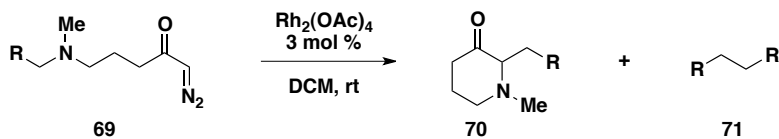

R	[1,2]-shift product Yield (%)	Dimer product Yield (%)
Ph	99	-
CO ₂ Et	94	-
<i>p</i> -AcC ₆ H ₄	71	25
<i>p</i> -MeOC ₆ H ₄	71	19

Table 2.2: Effect of aryl-substituents on [1,2]-shift.

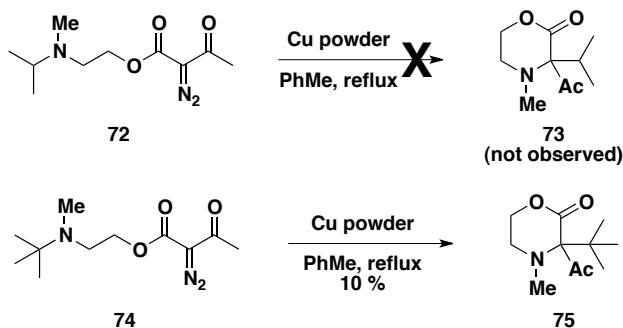

Scheme 2.9: Migration of non-conjugatively stabilized substituents.

The above trends are characteristic of molecules having little to no ring strain in the ylide intermediate. With the results observed by West and Vanecko during their ring expansion of azetidine **41** to pyrrolidine **43** (see Scheme 2.4) we can see that the introduction of ring strain into the ylide intermediate can change the normally observed migratory preferences of the Stevens [1,2]-shift reaction. In order to fully understand the potential of the azetidine ring in this application it is necessary to investigate its reactivity more thoroughly.

The goal of my first project in the West group involved exploring the chemistry of the Stevens rearrangement of azetidinium ylides. With the success of Vanecko's ring expansion reactions, we believed that there was potential for generalizing the methodology to provide an easy one-step pyrrolidine synthesis from simple, readily available building blocks. We also wanted to probe the effect of a strained ylide on the migratory preferences of the Stevens rearrangement in comparison with acyclic and larger ring systems. The results of these investigations, along with an improvement in the methodology, will be discussed herein.

2.5. The Intermolecular Ring Expansion of Azetidines to Pyrrolidines

2.5.1. Synthesis of Substrates

With a goal of examining the scope and limitations of azetidinium ylide [1,2]-shift as a route to pyrrolidines, a series of substituted azetidines was prepared. The first set of substrates, substituted with the carbomethoxy group at the 2-position, was prepared from γ -butyrolactone (**76**) in two steps. This sequence involved treating **76** with bromine in the presence of PBr_3 followed by hydrolysis with methanol to give dibromoester **77**, which was purified by vacuum distillation. Using the methods reported by Rodebaugh³⁷ and Wasserman³⁸ we were able to take dibromoester **77** and generate three different substrates (**41**, **78a** and **78b**) that could be used to probe the effect of the substituent on nitrogen on the Stevens rearrangement (Scheme 2.10).

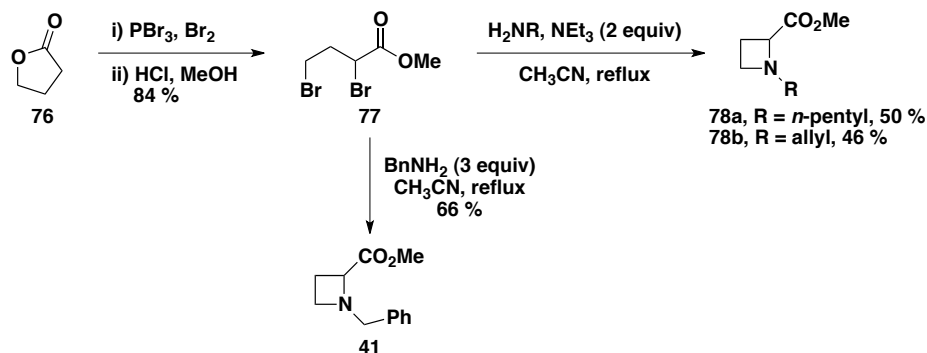

Scheme 2.10: Synthesis of N-alkyl-2-carbomethoxyazetidines.

In order to probe the effect that the release of ring strain would have on migratory selectivity two more azetidines were synthesized. The first, 2,2-dimethyl-N-benzyl azetidine (**78c**), would form a *tert*-alkyl radical upon bond homolysis, and the second, N-benzylazetidine (**78d**) would presumably proceed through a primary radical for the ring expansion reaction to occur. The synthesis of **78c** was accomplished using the procedure reported by Leonard and Durand in 1968 starting from 3,3-dimethylacrylic acid (**79**, Scheme 2.11).³⁹

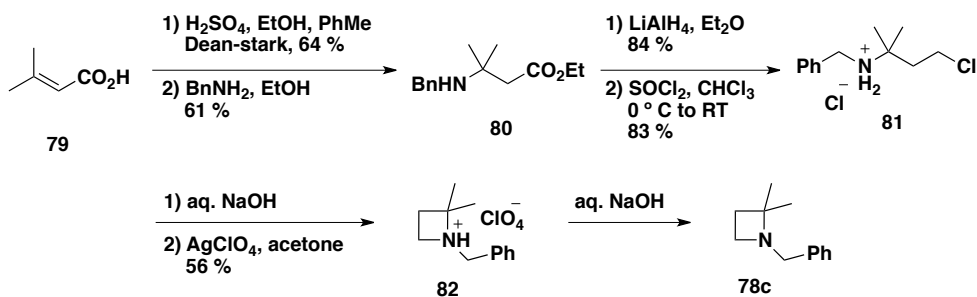

Scheme 2.11: Synthesis of 2,2-dimethyl-N-benzyl azetidine.

A route to **78d** was also found in the literature and could be accomplished in two steps (Scheme 2.12). Condensation of benzaldehyde (**83**) and the chloride salt of 3-bromopropylamine (**84**) gave the imine, which was reduced and subsequently heated to furnish the desired azetidine in good yield.⁴⁰

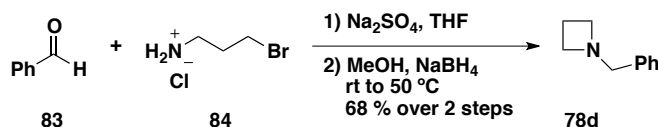

Scheme 2.12: Synthesis of N-benzylazetidinium.

Preparation of the diazocarbonyl compounds, excluding ethyl diazoacetate (**42**), which is commercially available, was accomplished using one of two general protocols (Scheme 2.13). The first protocol, the addition of ethereal diazomethane to a solution of benzoyl chloride (**85**) was used to synthesize diazoacetophenone (**86a**).⁴¹ The second protocol, for the synthesis of distabilized substrates **86b** and **86c**, utilized standard Regitz diazo transfer conditions.⁴²

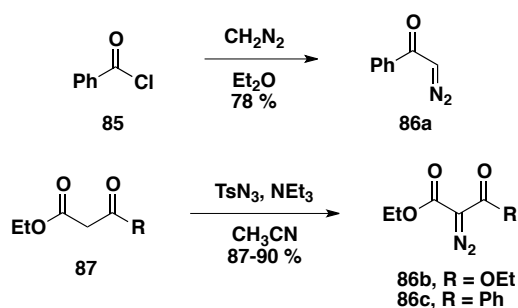

Scheme 2.13: Synthesis of diazocarbonyl compounds.

2.5.2. Optimization of the Reaction

With all of the desired substrates in hand we first utilized the conditions reported by West and Vanecko for the reaction of azetidine **41** and ethyl diazoacetate (**42**, Scheme 2.4). These optimized conditions involved 12 h slow addition of a solution of **42** in toluene to a solution of **41** (in excess) with Cu(tfacac)₂ (10 mol %) in toluene at reflux. An initial screen of catalysts revealed that the copper acetoacetonate series of catalysts all gave similar results but we found Cu(acac)₂ to be the most reproducible and used this for further studies (Table 2.3).

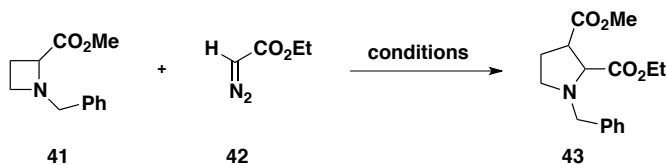

Catalyst	mol %	Yield (%)
Cu powder	10	39
Cu(acac) ₂	10	56
Cu(tfacac) ₂	10	50
Cu(hfacac) ₂	10	61
Rh ₂ (OAc) ₄	5	45

Table 2.3: Survey of catalysts for the formation of 43.

All possible combinations of azetidines (**41** and **78a-d**) and diazo compounds (**42** and **66a-c**) were subjected to the aforementioned reaction conditions to determine the generality of the ring-expansion process (Table 2.4). We were pleased to observe that in all but two cases, ring-expansion occurred preferentially over other possible reaction pathways.

Although this method was successful in generating some of the desired products with most of our substrates, the yields were not impressive. This was found to be especially problematic for cases using the distabilized diazocarbonyl substrates (**86b** and **86c**). We were not sure if this observation was due to a higher energy requirement for decomposition of the distabilized diazocarbonyl compounds or for the ring-expansion of the intermediate ylide. Our first thought was to explore other solvents that could be heated to higher temperatures. Unfortunately, there were not a lot of options available to us due to the fact that many of these higher boiling solvents would be incompatible with our catalyst. The use of xylenes was explored but resulted in very messy reactions. This could have been due to the fact that diazocarbonyl compounds and/or their metalcarbene derivatives can react with aromatic compounds to give Buchner ring enlargement products.⁴³

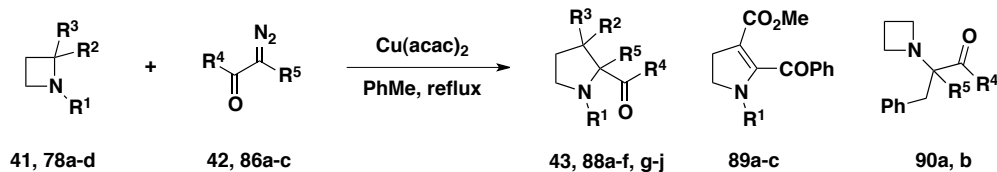

Entry	Azetidine	R ¹	R ²	R ³	Diazo	R ⁴	R ⁵	Product	Yield (%)
1	41	Bn	CO ₂ Me	H	42	OEt	H	43	56
2	41	Bn	CO ₂ Me	H	86b	OEt	CO ₂ Et	88a	67
3	41	Bn	CO ₂ Me	H	86a	Ph	H	89a	27
4	41	Bn	CO ₂ Me	H	86c	OEt	COPh	-	-
5	78a	pentyl	CO ₂ Me	H	42	OEt	H	88b	40
6	78a	pentyl	CO ₂ Me	H	86b	OEt	CO ₂ Et	88c	50
7	78a	pentyl	CO ₂ Me	H	86a	Ph	H	89b	52
8	78a	pentyl	CO ₂ Me	H	86c	OEt	COPh	88d	20
9	78b	allyl	CO ₂ Me	H	42	OEt	H	88e	31
10	78b	allyl	CO ₂ Me	H	86b	OEt	CO ₂ Et	88f	23
11	78b	allyl	CO ₂ Me	H	86a	Ph	H	89c	41
12	78b	allyl	CO ₂ Me	H	86c	OEt	COPh	88g	32
13	78c	Bn	Me	Me	42	OEt	H	88h	36
14	78c	Bn	Me	Me	86b	OEt	CO ₂ Et	-	-
15	78c	Bn	Me	Me	86a	Ph	H	88i	11
16	78c	Bn	Me	Me	86c	OEt	COPh	-	-
17	78d	Bn	H	H	42	OEt	H	88j	67
18	78d	Bn	H	H	86b	OEt	CO ₂ Et	90a	59
19	78d	Bn	H	H	86a	Ph	H	88k	39
20	78d	Bn	H	H	86d	OEt	COPh	90b	21

Table 2.4: Examination of substrate scope using standard reaction conditions.

We next turned to the use of microwave irradiation as a means of increasing the reaction temperature. This would allow us to explore solvents that would be compatible with the catalyst but whose boiling point was too low to permit the desired higher reaction temperatures using traditional heating methods. The temperature threshold of our reaction in toluene, dichloromethane and dichloroethane (DCE) were all examined. Upon optimization of solvent, reaction time, and temperature it was found that performing the reaction in DCE at 180 °C for 1 h could generate the same reaction products in most cases, albeit

with an increase in the formation of diazocarbonyl derived homodimers. This observation of homodimers was not unexpected, as the use of the microwave reactor does not allow for slow addition of the diazocarbonyl compound. The undesired side-reaction could be compensated for by changing the ratio of diazocarbonyl compound to azetidine from 1:1.5 to 2:1. All combinations of azetidine (**42** and **78a-d**) and diazocarbonyl compounds (**42** and **86a-c**) were subjected to the new microwave conditions and the improved cases are outlined in Table 2.5.

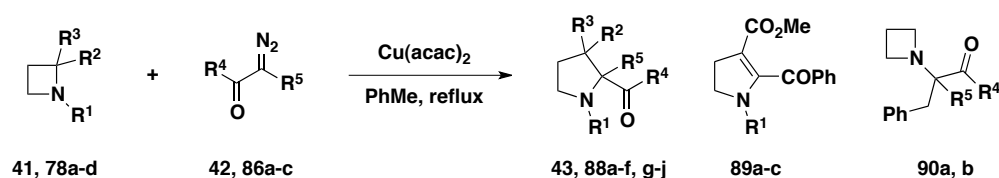

Entry	Azetidine	R ¹	R ²	R ³	Diazo	R ⁴	R ⁵	Product	Yield (%)
1	41	Bn	CO ₂ Me	H	42	OEt	H	43	66
2	41	Bn	CO ₂ Me	H	86c	OEt	CO ₂ Et	88a	81
3	41	Bn	CO ₂ Me	H	86b	Ph	H	89a	34
5	78a	pentyl	CO ₂ Me	H	42	OEt	H	88b	62
6	78a	pentyl	CO ₂ Me	H	86c	OEt	CO ₂ Et	88c	60
7	78a	pentyl	CO ₂ Me	H	86b	Ph	H	89b	65
9	78b	allyl	CO ₂ Me	H	42	OEt	H	88e	71
10	78b	allyl	CO ₂ Me	H	86c	OEt	CO ₂ Et	88f	69
11	78b	allyl	CO ₂ Me	H	86b	Ph	H	89c	48
13	78c	Bn	Me	Me	42	OEt	H	88h	62
15	78c	Bn	Me	Me	86b	Ph	H	88i	24

Table 2.5: Improvement in yields with microwave heating.

2.5.1. Discussion

An examination of our results listed in the tables above showed us that ring expansion was successful in most cases. Pyrrolidines **43**, **88b**, **88d**, **88e**, **88g**, and **88h** were, in most cases, isolated as an inseparable mixture of an approximately

1:1 ratio of diastereomers. This result was not a surprise to us considering the proposed reaction pathway. During the formation of the intermediate monocyclic ylide (**XXIV**), metallocarbene addition *cis* to the neighbouring ester was expected to dominate; however, both rotamers (**XXIX** and **XXIV'**) of the exocyclic C-N bond are likely to be present (Scheme 2.14). Even if the subsequent [1,2]-shift occurred with retention, as seen with spirocyclic ammonium ylides resulting from intramolecular metallocarbene addition,^{35, 44} both diastereomers would be expected. Additionally, if the intermediate biradical species (**XXV** and **XXV'**) persists for a long enough period of time randomization could occur, resulting in minimal diastereoselectivity.

Another possibility for the lack of observed diastereoselectivity in the reaction is that epimerization of one of both of the newly formed stereocenters could also be occurring. Unfortunately, due to our inability separate the mixtures of diastereomers, we were not able to probe for this by re-subjecting each of the pure diastereomers to the reaction conditions.

Varying the substituent on nitrogen had little impact on the yield of the ring-expansion. A comparison of the reactions of azetidines **41**, **78a** and **78b** with either ethyl diazoacetate (**42**) or diazomalonate **66b** showed no difference in the amount of pyrrolidine products formed with yields of 62-71 % (Table 2.5, entries 1, 5 and 9) and 60-81 % (Table 2.5, entries 2, 6 and 10) respectively. Additionally, the ammonium ylides derived from *N*-allyl azetidine **78b** which should also be capable of undergoing a [2,3]-rearrangement as commonly seen with other ammonium,⁴⁵ sulfonium⁴⁶ and oxonium ylides,⁴⁷ gave none of azetidine **91** as the final product (Scheme 2.15).

These results imply that the relief of ring strain is a strong driving force in these systems. Usually, when given the choice between [2,3]-shift and [1,2]-shift, ammonium ylides will preferentially undergo reaction via the [2,3] pathway due to the presumed lower reaction barrier for the concerted pathway vs. the stepwise homolytic pathway. In this case, it appears that the relief in ring strain associated with homolytic opening of the azetidinium ylide can alter this preference in favour of the [1,2] pathway.

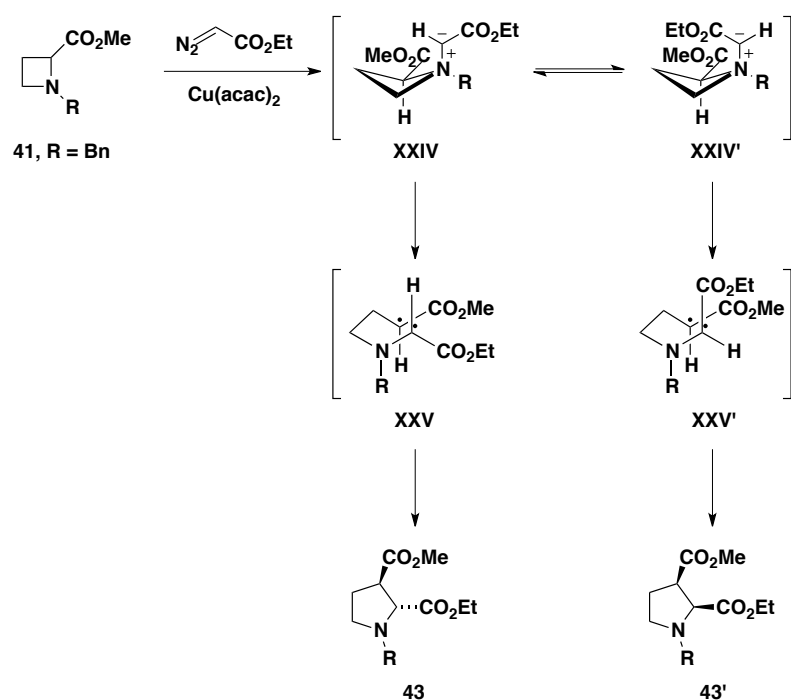

Scheme 2.14: Mechanistic rationale for the formation of diastereomers.

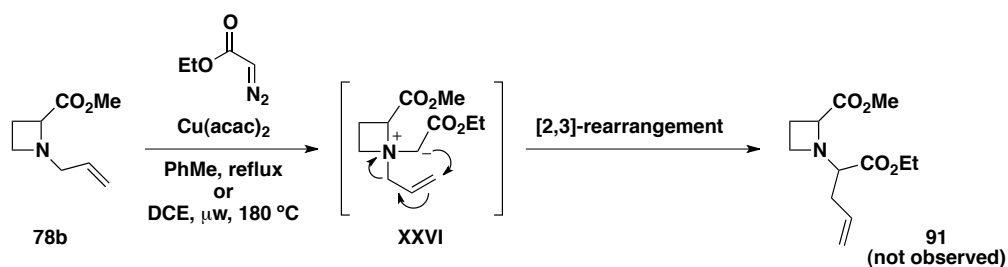

Scheme 2.15: Possible [2,3]-rearrangement pathway of N-allyl azetidine 78b.

We were also pleased that the ring expansion of N-pentyl-substituted azetidine **78a** occurred without any noticeable interference from α',β -fragmentation of the intermediately formed ylide (Scheme 2.16). This process, which would result in the formation of azetidine **92**, is sometimes observed as a side-reaction of ylides with easily accessible β -protons.⁴⁸

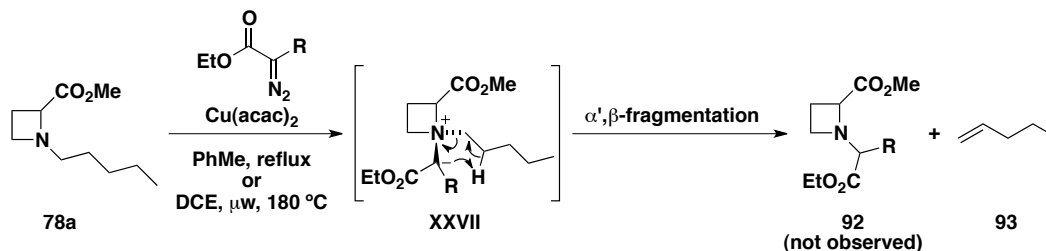

Scheme 2.16: Possible α',β -fragmentation pathway of N-pentyl azetidine **78a**

The products observed when azetidines **41**, **78a** and **78b** were allowed to react with mono-stabilized diazo **86a** were the result of ring expansion followed by a subsequent dehydrogenation (Scheme 2.17). This process may have resulted from initial formation of the pyrrolidine followed by reaction of the intermediate ylide tautomer (**XXVIII**) with ambient oxygen and intramolecular elimination of peroxide anion. The fast oxidation of the α -position in the benzoyl-substituted cases (Table 2.5, entries 3, 7 and 11) but not in the carboethoxy-substituted cases (Table 2.5, entries 1, 5 and 9) may be due to the greater acidity of the α -proton, making tautomerization a much more facile process.

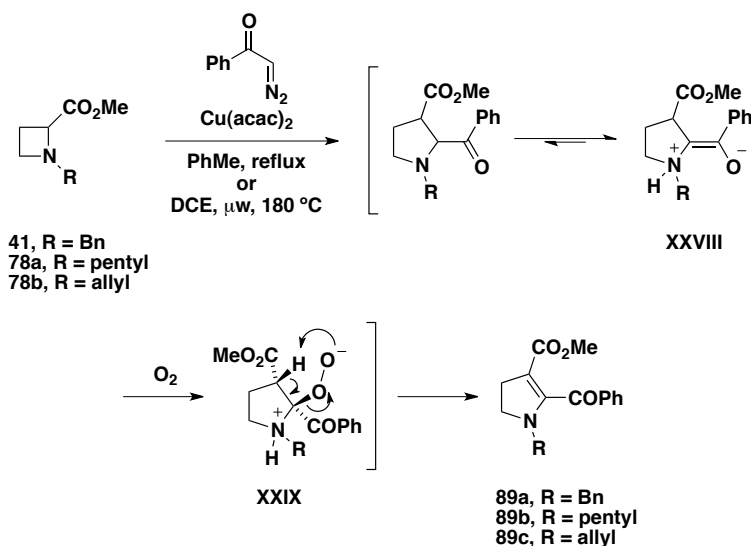

Scheme 2.17: Formation of dehydrogenated pyrrolidine products.

Both *N*-benzyl azetidine **78d** and the 2,2-dimethyl substituted azetidine **78c** gave us interesting results (Scheme 2.18). An early observation by Hata and

Watanabe suggested that this ring expansion was viable in the case of **78d** with **42** in the presence of $\text{Cu}(\text{acac})_2$,⁴⁹ but as there was only one example in the literature we were not sure to what extent this process would occur. In our hands, ring expansion to the pyrrolidine was observed with azetidine **78c** and the mono-stabilized diazocarbonyl compounds **42** and **86a** under both sets of reaction conditions, although purification and characterization of **88k** was hindered by its rapid conversion to *N*-benzylpyrrolidinone **94** and benzoic acid (**95**) (Scheme 2.19). Similar debenzoylative oxidations that may proceed through a similar pathway proposed for the formation of **89a-c** (Scheme 2.17) have been reported by Garcia-Valverde⁵⁰ and Yijima.⁵¹

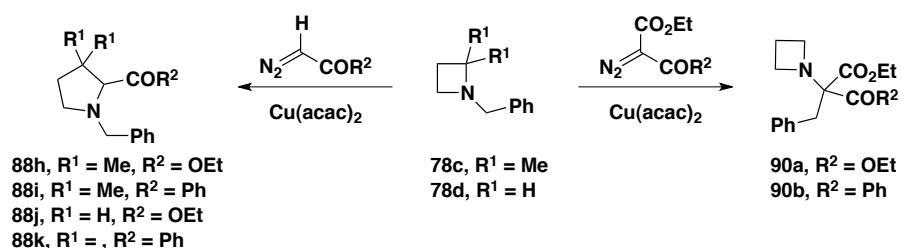

Scheme 2.18: Interesting results with azetidines **78c** and **78d**.

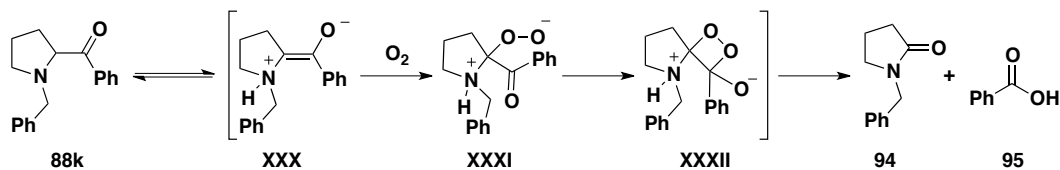

Scheme 2.19: Debenzoylative oxidation of pyrrolidine **88k**.

With *N*-benzylazetidine **78d** and diazo compounds **86b** and **86c**, we were able to isolate the [1,2]-benzyl shift products **90a** and **90b** (see Scheme 2.18). There is one example in the literature that reports the benzyl [1,2]-shift occurring preferentially over ring expansion.⁵² In this case, the authors allowed *N*-benzylazetidine **78d** to react with 3,3,3-trifluoro-2-diazopropionate **96** in the presence of rhodium acetate, which generated azetidine **97** in 65 % yield (Scheme 2.20). The trifluoromethyl group, although not conjugatively stabilizing like

CO₂Et or COPh, is a good electron-withdrawing group, which may be the reason the authors observed the benzyl [1,2]-shift in this particular example.

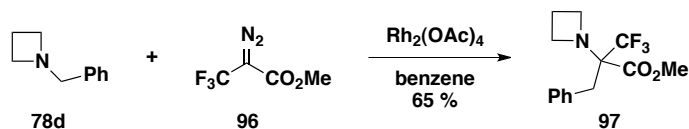

Scheme 2.20: Example of benzyl [1,2]-shift by Burger and coworkers.

These observations suggest that the ylide formed with distabilized diazocarbonyl compounds is either more stable or possibly more sensitive to the formation of a stabilized biradical intermediate, or proceeds through a different reaction mechanism. In order to probe this hypothesis a series of different diazo compounds with varying degrees of electron donating and electron withdrawing substituents should be synthesized and allowed to react with *N*-benzylazetidine **78d**.

The reaction of 2,2-dimethyl azetidine **78c** with either **86b** or **86c** was very messy and we were unable to isolate any identifiable products from the crude mixture. This was a bit surprising given that **76b** provided **90a** and **90b** in reasonable yields. After searching through the literature we found a report discussing the outcome of quaternization of azetidine **78c**, 1-benzyl-3,3-dimethylazetidine **98** and 1,2,2-trimethylazetidine **100** by alkylating with benzyl bromide (Scheme 2.21).³⁹ The authors found that both **98** and **100** could be alkylated with benzyl bromide to give the halide salts (**99** and **101**) but that **78c** was rapidly converted to amine **102** via Hofmann elimination. In our example, the possibility of an α' , β -fragmentation with one of the methyl groups might have led to similar results, however, at the elevated reaction temperatures used in our case polymerization and decomposition prevailed and we were not able to isolate any acyclic products to confirm this as a possible pathway (Scheme 2.22).

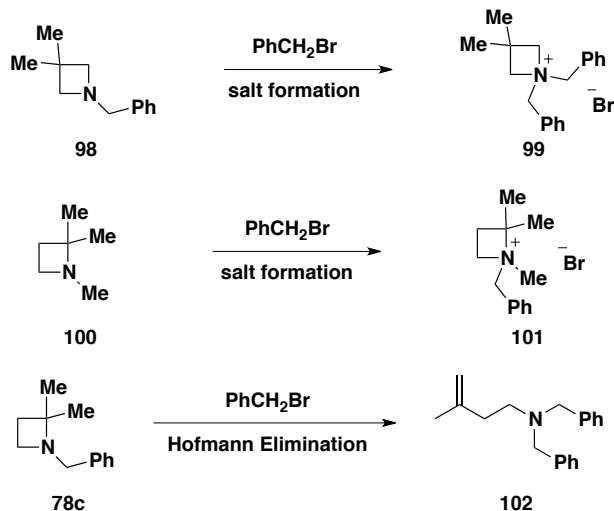

Scheme 2.21: Unexpected Hofmann elimination of 78c under quaternization conditions.

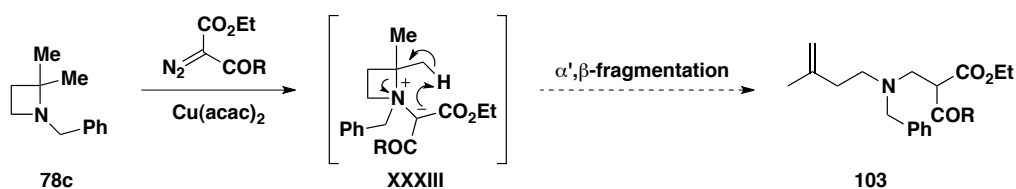

Scheme 2.22: Possible α' β -fragmentation pathway of ylide derived from 78c.

2.5.2. Conclusions

It has been established that the ring expansion of azetidines to pyrrolidines via the Stevens rearrangement of azetidinium ylides is a general process. A standard method, which allows for different combinations of readily available azetidines and diazocarbonyl compounds to react in the presence of catalytic $\text{Cu}(\text{acac})_2$, has been described. In most cases the use of microwave heating gave rise to cleaner reactions and higher yields in lower reaction times than those observed using traditional heating methods. This reaction results from addition of the basic nitrogen of the azetidine to an *in situ* generated metallocarbene, followed by (in most cases) regioselective [1,2]-shift of the azetidine ring carbon. This process showed different migratory preferences than those observed with unstrained acyclic and cyclic analogues. These unusual migratory preferences are

likely due to the relief of ring strain, even when other competent migrating groups such as benzyl or allyl are present on nitrogen. The migrating center could have a range of different substitution patterns, including (in the case of mono-substituted metallocarbenes) methylene. With access to many differently substituted azetidines (see Chapter 1) and diazocarbonyl compounds, this methodology provides an opportunity for the synthesis of a large array of pyrrolidine products.

2.5.3. Future Directions

With the success in accessing highly functionalized pyrrolidines in a quick and efficient manner we are now interested in expanding this methodology to access bicyclic systems possessing medium-sized rings. Molecules of this nature are prevalent in the frameworks of a variety of alkaloid natural products such as stemonamine or nakadomarin A. In this context, it will be necessary to find reliable methods for the synthesis of enantiomerically enriched starting materials possessing the proper functionality for subsequent transformations. Concurrently, we must also look into ways of controlling the diastereoselectivity of the ring expansions for this methodology to be successful on a broad scale.

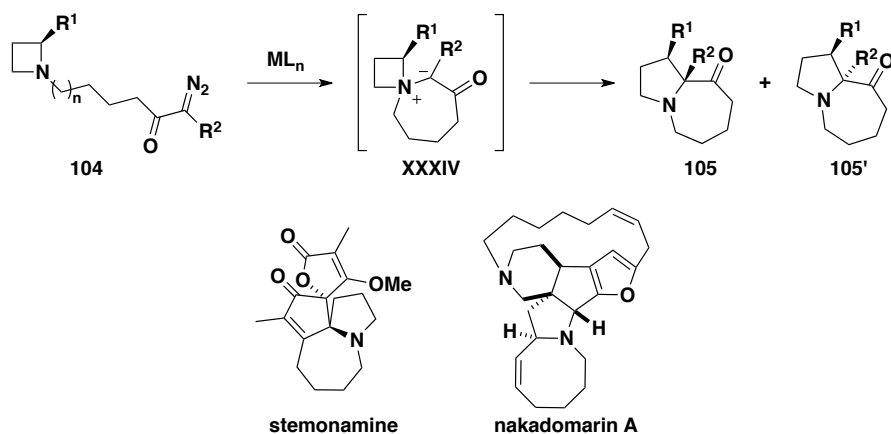

Scheme 2.23: Application of azetidine ring expansion to the formation of bicyclic systems.

A second notable observation of this ring expansion project was the different pathways of reactivity for *N*-benzylazetidines (**78d**), which possessed no stabilizing groups on the C-2 position of the ring. In order to probe this reactivity a series of different diazo compounds with varying degrees of electron donating and electron withdrawing substituents will be synthesized and reacted with *N*-benzylazetidines to determine the cutoff for the ring expansion process.

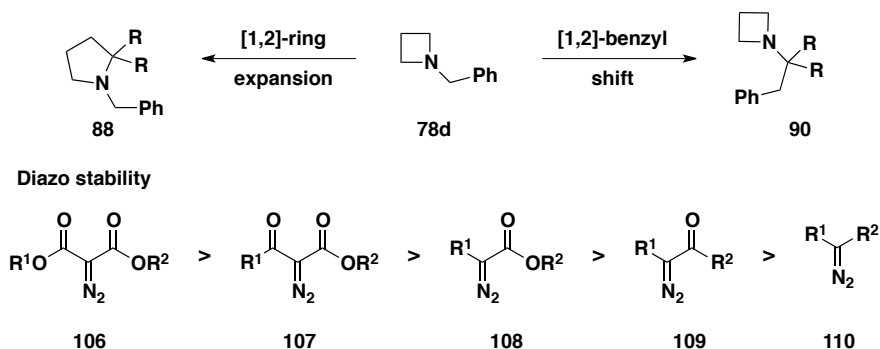

Scheme 2.24: Investigating the effect of diazo stability on ring expansion vs. benzyl migration.

2.6. Experimental

2.6.1. General Information

Reactions were carried out in oven (130 °C) or flame-dried glassware under a positive argon atmosphere unless otherwise stated. Transfer of anhydrous reagents was accomplished with oven-dried syringes or cannulae. Solvents were distilled before use: acetonitrile (CH₃CN), dichloroethane (DCE) and dichloromethane (DCM) from calcium hydride, diethyl ether (Et₂O) and toluene (PhMe) from sodium metal. Microwave heating was carried out in a Biotage Initiator microwave reactor, using 2-5 mL microwave vials. Reaction temperature was determined through measurement of the vial surface temperature using an infrared sensor, then corrected for internal temperature by the unit's processor using a proprietary algorithm. Thin layer chromatography was performed on glass plates pre-coated with 0.25 mm silica gel with fluorescent indicator UV₂₅₄

(Rose Scientific). Flash chromatography columns were packed with 230-400 mesh silica gel (Silacyle). Azetidines **41** and **78b-c** were prepared using the known procedures reported by Rodebaugh³⁷ and Wesserman.³⁸ Azetidine **78d** was synthesized using the method of Lenard and Durand³⁹ and azetidine **78d** by a procedure published by G. Lai.⁴⁰ Diazocarbonyl compounds **86a-c** were also known compounds which could be prepared according to known procedures.^{42, 41}

2.6.2. Characterization

General Procedures for Azetidine Ring Expansions

Method A: Solid Cu(tfacac)₂ (10 mol %) was added to a 0.025 M solution of azetidine (1.5 equiv) in PhMe. The mixture was heated to reflux before the addition of a 0.1 M solution of the diazocarbonyl compound (1 equiv) in PhMe via syringe pump over 12 h (0.100 mL/h) followed by an additional 12 h of reflux. The resulting solution was allowed to cool to rt and then washed with equivalent volumes of a 0.5 M aqueous solution of K₂CO₃ and brine. The combined organic layers were then dried over MgSO₄, filtered, concentrated under reduced pressure and purified by flash chromatography. In cases where Cu(0) was used as the catalyst, the reaction mixture was filtered through a plug of celite using 30 % EtOAc/hexanes before chromatography.

Method B: A 0.05 M solution of azetidine (1 equiv) in DCE was transferred *via* cannula into a 2-5 mL microwave vial containing 10 mol % Cu(acac)₂. A 0.5 M solution of the diazocarbonyl compound in DCE (2 equiv) was then added. The reaction mixture was subjected to microwave irradiation (either 150 °C or 180 °C) for 1h. The reaction mixture was then washed with equivalent volumes of 0.5 M aqueous K₂CO₃ solution and brine. The combined organic layers were dried over MgSO₄, filtered, concentrated under reduced pressure and purified by flash chromatography.

1-Benzylpyrrolidine-2,3,3-tricarboxylic acid 3-methyl ester 2,2-diethyl ester 88a:

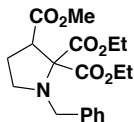

Yellow oil, $R_f = 0.37$ (6:1 hexanes:EtOAc); IR (thin film) 2982, 2842, 1731, 1495, 1454, 1367, 1214, 1098, 1028 cm^{-1} ; ^1H NMR (500 MHz, CDCl_3) δ 7.37-7.35 (m, 2H), 7.29-7.26 (m, 2H), 7.22-7.19 (m, 1H), 4.34-4.20 (m, 4H), 3.97 (d, $J = 13.5$ Hz, 1H), 3.85 (d, $J = 13.5$ Hz, 1H), 3.71 (dd, $J = 9.0, 8.4$ Hz, 1H), 3.68 (s, 3H), 2.92 (app td, $J = 8.8, 4.7$ Hz, 1H), 2.81 (app td, 8.5, 6.8 Hz, 1H), 2.24-2.13 (m, 2H), 1.30 (t, $J = 7.1$ Hz, 3H), 1.29 (t, $J = 7.2$ Hz, 3H); ^{13}C NMR (125 MHz, CDCl_3) δ 172.3, 169.1, 168.7, 139.6, 128.3, 128.2, 126.9, 76.9, 61.6, 61.3, 54.8, 52.0, 51.1, 50.4, 26.1, 14.2, 14.1. HRMS calculated for $\text{C}_{19}\text{H}_{25}\text{NO}_6\text{Na}$ $[\text{M} + \text{Na}]^+$ 386.1574, found 386.1577.

1-Pentylpyrrolidine-2,3-dicarboxylic acid 3-methyl ester 2-ethyl ester 88b:

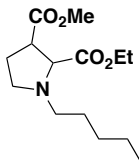

Reaction gave an ~1:1 mixture of diastereomers determined by GC analysis and integration of OMe singlets in the ^1H NMR spectrum; $R_f = 0.45$ (3:2 hexanes:EtOAc); IR (thin film) 2955, 2934, 2860, 1738, 1436, 1372, 1196, 1096, 1032 cm^{-1} ; ^1H NMR (400 MHz, CDCl_3) Diastereomer 1: δ 4.26-4.17 (m, 2H), 3.70 (s, 3H), 3.42 (d, $J = 6.5$ Hz, 1H), 3.20-3.16 (m, 2H), 2.71 (dt, $J = 11.7, 8.1$ Hz, 1H), 2.47 (app q, $J = 8.9$ Hz, 1H), 2.40 (app dt, $J = 11.9, 7.3$ Hz, 1H), 2.26-2.17 (m, 1H), 2.08 (dddd, $J = 12.8, 7.9, 4.8, 3.2$ Hz, 1H), 1.49 (p, $J = 7.5$ Hz, 2H), 1.36-1.24 (m, 7H), 1.28 (t, $J = 7.1$ Hz, 3H); Diastereomer 2 (extrapolated from mixture of diastereomers): δ 4.18-4.09 (m, 2H), 3.66 (d, $J = 8.4$ Hz, 1H), 3.65 (s, 3H), 3.26 (app q, $J = 9.2$ Hz, 1H), 3.03 (td, $J = 8.8, 3.9$ Hz, 1H), 2.72 (app q, $J =$

7.7 Hz, 1H), 2.57 (ddd, $J = 11.8, 8.7, 6.8$ Hz, 1H), 2.51-2.31 (m, 2H), 2.16-2.03 (m, 1H), 1.53-1.45 (m, 2H), 1.39-1.21 (m, 4H), 1.25 (t, $J = 6.8$ Hz, 3H), 0.88 (t, $J = 6.8$ Hz, 3H); ^{13}C NMR (125 MHz, CDCl_3) Diastereomer 1: δ 174.3, 172.7, 69.0, 60.9, 54.8, 52.9, 52.1, 47.1, 29.6, 28.1, 27.6, 22.5, 14.2, 14.0; Diastereomer 2 (extrapolated from mixture of diastereomers): 172.6, 171.4, 66.7, 60.3, 53.6, 51.8, 51.8, 46.5, 29.6, 28.1, 26.5, 22.5, 14.3, 14.0. HRMS calculated for $\text{C}_{14}\text{H}_{25}\text{NO}_4$ (M^+) 271.1783, found 271.1777.

1-Pentylpyrrolidine-2,3,3-tricarboxylic acid 3-methyl ester 2,2-diethyl ester 88c:

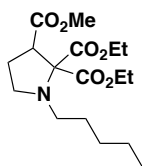

Yellow oil, $R_f = 0.41$ (4:1 hexanes:EtOAc); IR (thin film) 2957, 2933, 2860, 1732, 1446, 1367, 1267, 1214, 1104, 1025 cm^{-1} ; ^1H NMR (400 MHz, CDCl_3) δ 4.12-4.30 (m, 4H), 3.67 (s, 3H), 3.62 (app t, $J = 9.0$ Hz, 1H), 3.04-2.96 (m, 2H) 2.72 (ddd, $J = 11.8, 9.0, 6.0$, 1H), 2.66 (ddd, $J = 11.8, 8.9, 6.8$ Hz, 1H), 2.28-2.15 (m, 2H), 1.58-1.40 (m, 2H), 1.36-1.25 (m, 4H), 1.28 (t, $J = 7.2$ Hz, 3H), 1.26 (t, $J = 7.2$ Hz, 3H), 0.88 (t, $J = 7.0$, 3H); ^{13}C NMR (125 MHz, CDCl_3) δ 172.3, 169.2, 168.7, 76.8, 61.4, 61.1, 51.9, 51.1, 50.9, 50.7, 29.4, 28.7, 26.2, 22.6, 14.1, 14.1, 14.0. HRMS (ESI) calculated for $\text{C}_{17}\text{H}_{30}\text{NO}_6$ ($[\text{M}+\text{H}]^+$) 344.2068, found 344.2068.

2-Benzoyl-1-pentylpyrrolidine-2,3-dicarboxylic acid 2-ethyl ester 3-methyl ester 88d:

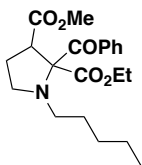

Reaction gave an inseparable ~1:1 mixture of diastereomers determined by GC analysis and integration of OMe singlets in the ^1H NMR spectrum; $R_f = 0.33$ (7:3 hexanes:EtOAc); IR (cast film) 2955, 2927, 2851, 1738, 1699, 1447, 1212, 1176, 1097, 1024, 694 cm^{-1} ; ^1H NMR (400 MHz, CDCl_3) Diastereomer 1 (extrapolated from mixture of diastereomers): δ 8.19-8.17 (m, 2H), 7.44-7.37 (m, 3H), 4.28-4.18 (m, 2H), 3.70 (t, $J = 9.5$ Hz, 1H), 3.60 (s, 3H), 3.39 (td, $J = 8.7, 5.5$ Hz, 1H), 2.88-2.79 (m, 2H), 2.69 (ddd, $J = 12.8, 10.3, 6.0$ Hz, 1H), 2.38-2.14 (m, 2H), 1.69-1.10 (m, 6H), 1.24 (t, $J = 7.2$ Hz, 3H), 0.80 (t, $J = 7.0$ Hz, 3H); Diastereomer 2 (extrapolated from mixture of diastereomers): δ 7.89-7.86 (m, 2H), 7.55-7.46 (m, 3H), 4.26-4.14 (m, 2H), 4.03 (dd, $J = 9.2, 6.6$ Hz, 1H), 3.42 (td, $J = 8.5, 2.6$ Hz, 1H), 3.27 (s, 3H), 2.82 (ddd, $J = 11.9, 10.3, 6.1$ Hz, 1H), 2.56 (app q, $J = 8.5$ Hz, 1H), 2.38-2.21 (m, 2H), 2.18 (ddd, $J = 11.9, 9.4, 5.2$ Hz, 1H), 1.60-1.10 (m, 6H), 1.12 (t, $J = 7.2$ Hz, 3H), 0.85 (t, $J = 7.1$ Hz, 3H); ^{13}C NMR (mixture of diastereomers) (125 MHz, CDCl_3) δ 197.3, 196.0, 173.0, 171.3, 169.2, 169.0, 136.7, 136.4, 132.4, 132.1, 129.0, 128.4, 128.0, 127.8, 82.7, 81.0, 77.1, 61.2, 61.0, 51.7, 51.6, 51.2, 50.6, 49.9, 49.0, 29.4, 29.3, 28.6, 28.3, 27.5, 24.6, 22.5, 22.3, 14.1, 14.1, 14.0, 13.9 (one carbon signal was not detected, possibly due to overlap with the solvent); HRMS (ESI) calculated for $\text{C}_{21}\text{H}_{30}\text{NO}_5$ ($[\text{M}+\text{H}]^+$) 376.2119, found 376.2115.

1-Allylpyrrolidine-2,3-dicarboxylic acid 3-methyl ester 2-ethyl ester 88e:

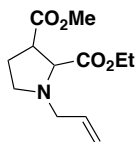

Reaction gave an inseparable ~1:1 mixture of diastereomers determined by GC analysis and integration of OMe singlets in the ^1H NMR spectrum; $R_f = 0.21$ (4:1 hexanes:EtOAc); IR (cast film) 2981, 2955, 2846, 1740, 1437, 1370, 1264, 1200, 1032 cm^{-1} ; ^1H NMR (400 MHz, CDCl_3) mixture of diastereomers δ 5.95-5.85 (m, 2H), 5.19 (app dddd, $J = 17.2, 6.5, 3.0, 1.5$ Hz, 2H), 5.11 (app dddd, $J = 10.0, 3.0, 2.0, 1.0$ Hz, 2H), 4.24-4.12 (m, 4H), 3.72 (s, 3H), 3.66 (d, $J = 8.5$ Hz, 1H),

3.66 (s, 3H), 3.47 (d, $J = 6.5$ Hz, 1H), 3.40 (app ddt, $J = 13.4, 6.0, 1.5$ Hz, 1H), 3.32-3.25 (m, 2H), 3.23-3.10 (m, 3H), 3.07 (app td, $J = 9.0, 4.0$ Hz, 1H), 2.72 (app dt, $J = 9.0, 7.5$ Hz, 1H), 2.53 (app td, $J = 9.0, 8.0$ Hz, 1H), 2.39-2.30 (m, 1H), 2.25-2.03 (m, 4H), 1.28 (t, $J = 7.0$ Hz, 3H), 1.26 (t, $J = 7.2$ Hz, 3H); ^{13}C NMR (125 MHz, CDCl_3) δ 174.2, 172.5, 172.5, 171.2, 134.9, 134.8, 117.8, 117.7, 68.0, 66.2, 61.0, 60.5, 57.4, 56.3, 52.7, 52.2, 51.9, 51.7, 47.2, 46.5, 27.6, 26.6, 14.2, 14.2; HRMS calculated for $\text{C}_{12}\text{H}_{19}\text{NO}_4$ (M^+) 241.1314, found 241.1317.

1-Allylpyrrolidine-2,3,3-tricarboxylic acid 3-methyl ester 2,2-diethyl ester 88f:

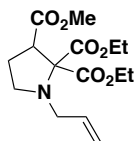

Yellow oil, $R_f = 0.29$ (4:1 hexanes:EtOAc); IR (thin film) 2982, 2820, 1731, 1438, 1367, 1262, 1215, 1119, 1026, 921, 858, 775 cm^{-1} ; ^1H NMR (400 MHz, CDCl_3) δ 5.89 (app ddt, $J = 17.0, 10.1, 6.3$ Hz, 1H), 5.18 (app dq, $J = 17.1, 1.6$ Hz, 1H), 5.07 (app dd, br, $J = 10.1, 1.6$ Hz, 1H), 3.35-4.12 (m, 4H), 3.68 (s, 3H), 3.67 (t, $J = 8.9$ Hz, 1H), 3.43 (app ddt, $J = 13.6, 6.2, 1.3$ Hz, 1H), 3.33 (dd, $J = 13.6, 6.3$ Hz, 1H), 3.05-2.90 (m, 2H), 2.24-2.17 (m, 2H), 1.29 (t, $J = 7.1$, 3H), 1.27 (t, $J = 7.1$, 3H); ^{13}C NMR (125 MHz, CDCl_3) δ 172.3, 169.1, 168.6, 136.1, 116.3, 76.6, 61.6, 61.2, 53.9, 51.9, 51.1, 50.7, 26.2, 14.1, 14.1; HRMS calculated for $\text{C}_{15}\text{H}_{24}\text{NO}_5$ [$\text{M} + \text{H}$] $^+$ 314.1598, found 314.1599.

2-Benzoyl-1-allylpyrrolidine-2,3-dicarboxylic acid 2-ethyl ester 3-methyl ester 88g:

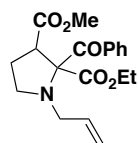

Reaction gave an inseparable ~1:1 mixture of diastereomers determined by GC analysis and integration of OMe singlets in the ^1H NMR spectrum; $R_f = 0.30$ (7:3 hexanes:EtOAc); IR (thin film) 3070, 2961, 2851, 1741, 1687, 1597, 1448, 1368, 1261, 1201, 1099, 1025, 924, 803, 715, 697 cm^{-1} ; ^1H NMR (400 MHz, CDCl_3) Diastereomer 1: δ 8.21-8.19 (m, 2H), 7.54 (app tt, $J = 1.2, 7.2$ Hz, 1H), 7.45-7.41 (m, 2H), 5.77 (ddt, $J = 17.1, 10.4, 6.4$ Hz, 1H), 5.15 (app dq, $J = 17.1, 1.6$ Hz, 1H), 5.06 (app dq, $J = 10.4, 1.6$ Hz, 1H), 4.31-4.15 (m, 2H), 3.72 (t, $J = 9.6$ Hz, 1H), 3.61 (s, 3H), 3.43 (app dt, $J = 6.4, 1.6$ Hz, 2H), 3.33 (td, $J = 9.0, 5.6$ Hz, 1H), 2.79 (td, $J = 9.6, 5.6$ Hz, 1H), 2.34-2.17 (m, 2H), 1.26 (t, $J = 7.2$ Hz, 3H); Diastereomer 2: δ 7.89 (d, $J = 8.0$ Hz, 2H), 7.50 (t, $J = 7.2$ Hz, 1H), 7.40 (t, $J = 8.0$ Hz, 2H), 5.90 (dddd, $J = 17.0, 10.0, 8.0, 4.5$ Hz, 1H), 5.14 (app dp, $J = 17.0, 1.0$ Hz, 1H), 5.06 (br d, $J = 10.0$ Hz, 1H), 4.20-4.14 (m, 2H), 4.09 (dd, $J = 9.2, 6.7$ Hz, 1H), 3.62 (br d, $J = 13.5$ Hz, 1H), 3.36 (td, $J = 8.6, 2.8$ Hz, 1H), 3.27 (s, 3H), 2.78 (dd, $J = 13.7, 7.7$ Hz, 1H), 2.54 (app q, $J = 8.6$ Hz, 1H), 2.36-2.29 (m, 1H), 2.26-2.19 (m, 1H), 1.21 (t, $J = 7.2$ Hz, 3H); ^{13}C NMR (125 MHz, CDCl_3) Diastereomer 1: δ 197.0, 171.3, 169.0, 136.3, 135.4, 132.7, 129.3, 129.1, 128.3, 117.1, 82.5, 61.2, 53.7, 51.8, 49.2, 24.6, 14.1; Diastereomer 2: δ 195.6, 173.0, 169.0, 136.5, 136.1, 132.4, 128.5, 128.1, 116.5, 80.5, 61.5, 54.2, 51.9, 51.8, 50.0, 29.7, 27.5, 14.0; HRMS (ESI) calculated for $\text{C}_{19}\text{H}_{24}\text{NO}_5$ $[\text{M} + \text{H}]^+$ 346.1649, found 346.1649.

1-Benzyl-3,3-dimethylproline ethyl ester 88h:

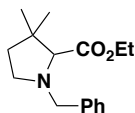

Yellow oil, $R_f = 0.23$ (12:1 hexanes:EtOAc); IR (cast film) 2960, 2872, 2803, 1746, 1728, 1495, 1454, 1368, 1343, 1239, 1177, 1030, 750, 700 cm^{-1} ; ^1H NMR (500 MHz, CDCl_3) δ 7.34-7.21 (m, 5H), 4.21-4.10 (m, 2H), 3.86 (d, $J = 13.2$ Hz, 1H), 3.53 (d, $J = 13.2$ Hz, 1H), 3.02 (app td, $J = 8.7, 3.5$ Hz, 1H), 2.98 (s, 1H), 2.51 (app q, $J = 8.0$ Hz, 1H), 1.76 (app dt, $J = 12.5, 8.5$ Hz, 1H), 1.58 (ddd, $J =$

12.2, 7.7, 3.2 Hz, 1H), 1.27 (t, $J = 7.0$, Hz, 3H), 1.18 (s, 3H), 1.02 (s, 3H); ^{13}C NMR (125 MHz, CDCl_3) δ 172.8, 138.5, 129.1, 128.1, 126.9, 75.9, 60.0, 58.4, 51.1, 41.9, 39.3, 29.4, 25.5, 14.4; HRMS calculated for $\text{C}_{16}\text{H}_{23}\text{NO}_2$ (M^+) 261.1729, found 261.1730.

1-Benzyl-2-benzoyl-3,3-dimethyl-pyrrolidine 88i:

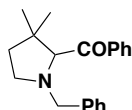

Yellow oil, $R_f = 0.21$ (12:1 hexanes:EtOAc); IR (cast film) 3062, 3085, 3027, 2958, 2930, 2869, 2802, 1681, 1597, 1578, 1494, 1466, 1447, 1367, 1229, 1180, 1157, 1127, 1075, 1028, 1002, 910, 859, 827, 745, 695, 674 cm^{-1} ; ^1H NMR (400 MHz, CDCl_3) δ 7.93 (app d, $J = 8.8$ Hz, 2H), 7.55 (app tt, $J = 1.6, 7.4$ Hz, 1H), 7.44 (app t, $J = 7.6$ Hz, 2H), 7.28-7.21 (m, 5H), 3.93 (s, 1H), 3.88 (d, $J = 13.2$ Hz, 1H), 3.57 (d, $J = 13.2$ Hz, 1H), 3.14 (app td, $J = 8.6, 2.4$ Hz, 1H), 2.66 (app td, $J = 9.0, 7.6$ Hz, 1H), 1.88 (app dt, $J = 12.1, 8.8$ Hz, 1H), 1.65 (ddd, $J = 12.2, 7.4, 2.8$ Hz, 1H), 1.19 (s, 3H), 0.90 (s, 3H); ^{13}C NMR (125 MHz, CDCl_3) δ 201.9, 138.6, 138.4, 132.7, 129.2, 128.5, 128.3, 128.1, 126.9, 76.7, 58.2, 51.1, 42.4, 40.1, 30.0, 26.1; HRMS calculated for $\text{C}_{20}\text{H}_{24}\text{NO}$ ($[\text{M}+\text{H}]^+$) 294.1852, found 294.1852.

1-Benzyl-2-benzoylpyrrolidine 88j:

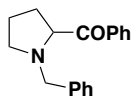

Yellow oil, $R_f = 0.25$ (12:1 hexanes:EtOAc); IR (cast film) 3062, 3028, 2958, 2927, 2855, 2801, 1721, 1689, 1597, 1448, 1277, 1223, 700 cm^{-1} ; ^1H NMR (500 MHz, CDCl_3) δ 8.04-8.02 (m, 2H), 7.57-7.54 (m, 1H), 7.47-7.43 (m, 2H), 7.31-7.22 (m, 5H), 4.02 (dd, $J = 9.4, 6.8$ Hz, 1H), 3.97 (d, $J = 12.8$ Hz, 1H), 3.49 (d, $J = 12.8$ Hz, 1H), 3.18-3.14 (m, 1H), 2.46 (app dt, $J = 9.0, 8.5$ Hz, 1H), 2.35-2.32

(m, 1H), 2.03-1.83 (m, 3H); ^{13}C NMR (125 MHz, CDCl_3) δ 200.5, 138.3, 136.1, 132.9, 129.3, 128.6, 128.4, 128.2, 127.0, 68.9, 58.5, 53.1, 29.9, 23.1.

1-Benzyl-2-benzoyl-4,5-dihydro-1-*H*-pyrrole-3-carboxylic acid ethyl ester
89a:

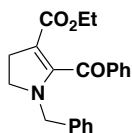

Yellow oil, $R_f = 0.27$ (5:1 hexanes:EtOAc); IR (cast film) 3062, 3030, 2946, 2855, 1678, 1581, 1495, 1450, 1430, 1352, 1317, 1273, 1222, 1186, 1116, 1053, 1028, 1001, 945, 879, 758, 701 cm^{-1} ; ^1H NMR (500 MHz, CDCl_3) δ 8.04-8.02 (m, 2H), 7.65-7.61 (m, 1H), 7.53-7.50 (m, 2H), 7.31-7.25 (m, 3H), 7.19-7.17 (m, 2H), 4.06 (s, 2H), 3.47 (t, $J = 10.5$ Hz, 2H), 3.46 (s, 3H), 2.92 (t, $J = 10.2$ Hz, 2H); ^{13}C NMR (125 MHz, CDCl_3) δ 192.2, 165.6, 158.3, 136.0, 135.6, 134.3, 129.2, 128.8, 128.6, 128.1, 127.8, 100.8, 52.7, 51.8, 50.6, 27.4; HRMS calculated for $\text{C}_{20}\text{H}_{19}\text{NO}_3$ (M^+) 321.1365, found 321.1363.

1-Pentyl-2-benzoyl-4,5-dihydro-1-*H*-pyrrole-3-carboxylic acid ethyl ester
89b:

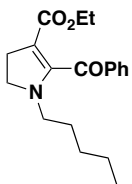

Yellow oil, $R_f = 0.38$ (4:1 hexanes:EtOAc); IR (cast film) 2954, 2932, 2860, 1679, 1582, 1491, 1450, 1431, 1352, 1317, 1218, 1187, 1110, 1042, 1023, 880, 758, 712 cm^{-1} ; ^1H NMR (500 MHz, CDCl_3) δ 7.98 (d, $J = 7.2$ Hz, 2H), 7.63-7.60 (m, 1H), 7.49 (t, $J = 7.7$ Hz, 2H), 3.61 (t, $J = 10.2$ Hz, 2H), 3.42 (s, 3H), 2.94 (t, $J = 10.2$ Hz, 2H), 2.88 (t, $J = 7.2$ Hz, 2H), 1.43 (p, $J = 7.2$ Hz, 2H), 1.20-1.10 (m, 4H), 0.79 (t, $J = 7.0$ Hz, 3H); ^{13}C NMR (125 MHz, CDCl_3) δ 192.4, 165.6, 158.9,

135.6, 134.1, 129.1, 128.8, 99.9, 51.9, 50.5, 48.5, 28.6, 27.7, 27.4, 22.1, 13.8;
HRMS calculated for C₁₈H₂₃NO₃ (M⁺) 301.1678, found 301.1675.

1-Allyl-2-benzoyl-4,5-dihydro-1-H-pyrrole-3-carboxylic acid ethyl ester 89c:

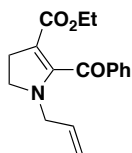

Yellow oil, R_f = 0.44 (7:3 hexanes:EtOAc); IR (cast film) 3064, 2945, 2860, 1679, 1582, 1486, 1450, 1431, 1351, 1317, 1287, 1225, 1188, 1113, 1051, 1024, 1000, 934, 879, 758, 713 cm⁻¹; ¹H NMR (500 MHz, CDCl₃) δ 8.01 (dd, *J* = 8.0, 1.2 Hz, 2H), 7.63 (tt, *J* = 7.4, 1.2 Hz, 1H), 7.51 (app t, *J* = 8.0 Hz, 2H), 5.68 (ddt, *J* = 17.4, 10.0, 6.3 Hz, 1H), 5.17 (app dq, *J* = 5.2, 1.2 Hz, 1H), 5.14 (app dq, *J* = 10.0, 1.2 Hz, 1H), 3.59 (t, *J* = 10.2 Hz, 2H), 3.52 (app dt, *J* = 6.4, 1.2 Hz, 2H), 3.44 (s, 3H), 2.95 (t, *J* = 10.2 Hz, 2H); ¹³C NMR (125 MHz, CDCl₃) δ 192.1, 165.6, 158.2, 135.5, 134.2, 132.8, 129.1, 128.8, 118.1, 101.2, 51.7, 51.2, 50.5, 27.4; HRMS calculated for C₁₆H₁₇NO₃ (M⁺) 271.1209, found 271.1209.

2-Azetidin-1-yl-2-benzyl-malonic acid diethyl ester 90a:

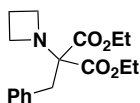

Yellow oil, R_f = 0.31 (7:3 hexanes:EtOAc); IR (neat film) 3031, 2979, 2938, 2872, 1751, 1728, 1497, 1455, 1222, 1191, 1123, 1103, 1040, 699 cm⁻¹; ¹H NMR (400 MHz, CDCl₃) δ 7.27-7.18 (m, 5H), 4.23-4.15 (m, 4H), 3.56 (t, *J* = 7.2, 4H), 3.11 (s, 2H) 2.05 (p, *J* = 7.2, 2H), 1.23 (t, *J* = 7.1, 6H); ¹³C NMR (125 MHz, CDCl₃) δ 168.5, 135.9, 130.1, 128.0, 126.7, 74.3, 60.9, 50.5, 37.6, 16.4, 14.2; HRMS calculated for C₁₇H₂₃NO₄ (M⁺) 305.1627, found 305.1623.

2-Azetidin-1-yl-2-benzyl-3-oxo-3-phenyl-propionic acid ethyl ester 90b:

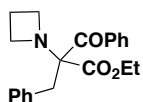

Yellow oil, $R_f = 0.26$ (19:1 hexanes:EtOAc); IR (thin film) 3063, 3030, 2968, 2935, 2870, 1727, 1690, 1597, 1496, 1448, 1216, 1026, 756, 698 cm^{-1} ; ^1H NMR (300 MHz, CDCl_3) δ 7.83-7.80 (m, 2H), 7.47-7.43 (m, 1H), 7.36-7.30 (m, 2H), 7.17-7.09 (m, 5H), 4.26-3.99 (m, 2H), 3.54 (app q, $J = 6.8$ Hz, 2H), 3.45 (app q, $J = 6.9$ Hz, 2H), 3.37 (d, $J = 14.2$ Hz, 1H), 3.30 (d, $J = 14.2$ Hz, 1H), 2.04 (app p, $J = 7.2$ Hz, 2H), 1.08 (t, $J = 7.1$ Hz, 3H); ^{13}C NMR (100 MHz, CDCl_3) δ 196.3, 169.7, 137.2, 136.2, 132.6, 130.7, 129.2, 128.3, 128.2, 126.9, 77.9, 61.1, 50.7, 37.6, 17.1, 14.3; HRMS (ESI) calculated for $\text{C}_{21}\text{H}_{24}\text{NO}_3$ ($[\text{M} + \text{H}]^+$) 338.1751, found 338.1751.

2.7. References

1. (a) O'Hagan, D., *Nat. Prod. Rep.* **1997**, *14* (6), 637-651; (b) Mitchinson, A.; Nadin, A., *J. Chem. Soc., Perkin Trans. 1* **1999**, (18), 2553-2581; (c) O'Hagan, D., *Nat. Prod. Rep.* **2000**, *17* (5), 435-446.
2. (a) Wagner, F. F.; Comins, D. L., *Tetrahedron* **2007**, *63* (34), 8065-8082; (b) Wu, G.; Bazer, F.; Burghardt, R.; Johnson, G.; Kim, S.; Knabe, D.; Li, P.; Li, X.; McKnight, J.; Satterfield, M.; Spencer, T., *Amino Acids* **2011**, *40* (4), 1053-1063-1063.
3. Schwartz, R. E.; Liesch, J.; Hensens, O.; Zitano, L.; Honeycutt, S.; Garrity, G.; Fromtling, R. A.; Onishi, J.; Monaghan, R., *J Antibiot (Tokyo)* **1988**, *41* (12), 1774-1779.
4. (a) Sobin, B. A.; Tanner, F. W., Jr., *J. Am. Chem. Soc.* **1954**, *76*, 4053; (b) Schwardt, O.; Veith, U.; Gaspard, C.; Jager, V., *Synthesis* **1999**, (Spec. Iss.), 1473-1490.

5. Wolfe, J. P., *Eur. J. Org. Chem.* **2007**, (4), 571-582.
6. Shibano, M.; Kitagawa, S.; Nakamura, S.; Akazawa, N.; Kusano, G., *Chem. Pharm. Bull.* **1997**, *45* (4), 700-705.
7. McGeer, P. L.; McGeer, E. G.; Hattori, T., *Kainic Acid Tool Neurobiol.* **1978**, 123-138.
8. (a) Parsons, A. F., *Tetrahedron* **1996**, *52* (12), 4149-4174; (b) Moloney, M. G., *Nat. Prod. Rep* **2002**, *19* (5), 597-616; (c) Scott, M. E.; Lautens, M., *Org. Lett.* **2005**, *7* (14), 3045-3047; (d) Clayden, J.; Read, B.; Hebditch, K. R., *Tetrahedron* **2005**, *61* (24), 5713-5724; (e) Jung, Y. C. A new approach to kainoids: Total syntheses of (-)-kainic acid and (+)-allokainic acid. 2006; (f) Sakaguchi, H.; Tokuyama, H.; Fukuyama, T., *Org. Lett.* **2007**, *9* (9), 1635-1638; (g) Sakaguchi, H.; Tokuyama, H.; Fukuyama, T., *Org. Lett.* **2008**, *10* (9), 1711-1714; (h) Farwick, A.; Helmchen, G., *Org. Lett.* **2010**, *12* (5), 1108-1111; (i) Takita, S.; Yokoshima, S.; Fukuyama, T., *Org. Lett.* **2011**, *13* (8), 2068-2070; (j) Kamon, T.; Irifune, Y.; Tanaka, T.; Yoshimitsu, T., *Org. Lett.* **2011**, *13* (10), 2674-2677.
9. (a) Erkkila, A.; Majander, I.; Pihko, P. M., *Chem. Rev.* **2007**, *107* (12), 5416-5470; (b) Lelais, G.; MacMillan, D. W. C., *New Frontiers in Asymmetric Catalysis* **2007**, 313-358; (c) Mukherjee, S.; Yang, J. W.; Hoffmann, S.; List, B., *Chem. Rev.* **2007**, *107* (12), 5471-5569; (d) Barbas, C. F., III, *Angew. Chem., Int. Ed.* **2008**, *47* (1), 42-47; (e) Verkade, J. M. M.; vanHemert, L. J. C.; Quaedflieg, P. J. L. M.; Rutjes, F. P. J. T., *Chem. Soc. Rev.* **2008**, *37* (1), 29-41; (f) Akiyama, T., *Fain Kemikaru* **2010**, *39* (8), 5-9; (g) Merino, P.; Marques-Lopez, E.; Tejero, T.; Herrera, R. P., *Synthesis* **2010**, (1), 1-26; (h) Yang, H.; Carter, R. G., *Synlett* **2010**, (19), 2827-2838.
10. Ahrendt, K. A.; Borths, C. J.; MacMillan, D. W. C., *J. Am. Chem. Soc.* **2000**, *122* (17), 4243-4244.
11. Chow, S. S.; Nevalainen, M.; Evans, C. A.; Johannes, C. W., *Tetrahedron Lett.* **2007**, *48* (2), 277-280.

12. Ramachary, D. B.; Ramakumar, K.; Kishor, M., *Tetrahedron Lett.* **2005**, *46* (41), 7037-7042.
13. Melchiorre, P.; Jørgensen, K. A., *J. Org. Chem.* **2003**, *68* (11), 4151-4157.
14. List, B.; Lerner, R. A.; Barbas, C. F., *J. Am. Chem. Soc.* **2000**, *122* (10), 2395-2396.
15. Cobb, A. J. A.; Shaw, D. M.; Ley, S. V., *Synlett* **2004**, (3), 558-560.
16. (a) Stanley, L. M.; Sibi, M. P., *Chem. Rev.* **2008**, *108* (8), 2887-2902; (b) Companyo, X.; Alba, A.-N.; Rios, R., *Targets in Heterocyclic Systems* **2009**, *13*, 147-174; (c) Hameed, S.; Akhtar, T., *Curr. Org. Chem.* **2011**, *15* (5), 694-711.
17. Minatti, A.; Muniz, K., *Chem. Soc. Rev.* **2007**, *36* (7), 1142-1152.
18. Yang, Q.; Ney, J. E.; Wolfe, J. P., *Org. Lett.* **2005**, *7* (13), 2575-2578.
19. Larock, R. C.; Hightower, T. R.; Hasvold, L. A.; Peterson, K. P., *J. Org. Chem.* **1996**, *61* (11), 3584-3585.
20. Tamaru, Y.; Hojo, M.; Higashimura, H.; Yoshida, Z., *J. Am. Chem. Soc.* **1988**, *110* (12), 3994-4002.
21. (a) Pearson, W. H., *Pure Appl. Chem.* **2002**, *74* (8), 1339-1347; (b) Pandey, G.; Banerjee, P.; Gadre, S. R., *Chem. Rev.* **2006**, *106* (11), 4484-4517.
22. Trost, B. M., *Angew. Chem. Int. Ed.* **1986**, *25* (1), 1-20.
23. Trost, B. M.; Marrs, C. M., *J. Am. Chem. Soc.* **1993**, *115* (15), 6636-6645.
24. Couty, F.; Evano, G., *Synlett* **2009**, (19), 3053-3064.
25. Vanecko, J. A.; West, F. G., *Org. Lett.* **2005**, *7* (14), 2949-2952.
26. Vanecko, J. A.; Wan, H.; West, F. G., *Tetrahedron* **2006**, *62* (6), 1043-1062.

27. Lepley, A. R.; Giumanini, A. G. In *Mechanisms of Molecular Migrations*, Thygarajan, B. S., Ed.; Interscience: New York, 1971; Vol. 3, pp 297-440.
28. Stevens, T. S.; Creighton, E. M.; Gordon, A. B.; MacNicol, M., *J. Chem. Soc.* **1928**, 3193-3197.
29. (a) Vedejs, E.; Martinez, G. R., *J. Am. Chem. Soc.* **1979**, *101* (21), 6452-6454; (b) Vedejs, E.; West, F. G., *Chem. Rev.* **1986**, *86* (5), 941-955.
30. (a) Sato, Y.; Sakakibara, H., *J. Organomet. Chem.* **1979**, *166* (3), 303-307; (b) Sato, Y.; Yagi, Y.; Koto, M., *J. Org. Chem.* **1980**, *45* (4), 613-617.
31. Bamford, W. R.; Stevens, T. S., *J. Chem. Soc.* **1952**, (Dec), 4735-4740.
32. Zhang, J. J.; Schuster, G. B., *J. Org. Chem.* **1988**, *53* (4), 716-719.
33. West, F. G.; Glaeske, K. W.; Naidu, B. N., *Synthesis* **1993**, (10), 977-980.
34. Kerr, J. A., *Chem. Rev.* **1966**, *66* (5), 465-500.
35. West, F. G.; Naidu, B. N., *J. Am. Chem. Soc.* **1993**, *115* (3), 1177-1178.
36. West, F. G.; Naidu, B. N., *J. Org. Chem.* **1994**, *59* (20), 6051-6056.
37. Rodebaugh, R. M.; Cromwell, N. H., *J. Heterocycl. Chem.* **1968**, *5* (2), 309-311.
38. Wasserman, H. H.; Lipshutz, B. H.; Tremper, A. W.; Wu, J. S., *J. Org. Chem.* **1981**, *46* (15), 2991-2999.
39. Leonard, N. J.; Durand, D. A., *J. Org. Chem.* **1968**, *33* (4), 1322-1333.
40. Lai, G., *Synth. Commun.* **2001**, *31* (4), 565-568.
41. Jung, M. E.; Min, S.-J.; Houk, K. N.; Ess, D., *J. Org. Chem.* **2004**, *69* (26), 9085-9089.

42. Doyle, M. P.; Mckerverve, M. A.; Ye, T., *Modern Catalytic Methods for Organic Synthesis with Diazo Compounds: From Cyclopropanes to Ylides*. Wiley-Interscience: 1998; p 652.
43. (a) Buchner, E., *Ber.* **1896**, *29*, 106-109; (b) Buchner, E.; Feldmann, L., *Ber.* **1903**, *36*, 3509-3517; (c) Smith, L. I.; Tawney, P. O., *J. Am. Chem. Soc.* **1934**, *56*, 2167-2169.
44. (a) Naidu, B. N.; West, F. G., *Tetrahedron* **1997**, *53* (48), 16565-16574; (b) Glaeske, K. W.; Naidu, B. N.; West, F. G., *Tetrahedron Asymmetry* **2003**, *14* (7), 917-920.
45. (a) Jemison, R. W.; Laird, T.; Ollis, W. D.; Sutherland, I. O., *J. Chem. Soc., Perkin Trans. I* **1980**, (7), 1450-1457; (b) Roberts, E.; Sancon, J. P.; Sweeney, J. B., *Org. Lett.* **2005**, *7* (10), 2075-2078.
46. Vedejs, E.; Arnost, M. J.; Hagen, J. P., *J. Org. Chem.* **1979**, *44* (18), 3230-3238.
47. (a) West, F. G.; Eberlein, T. H.; Tester, R. W., *J. Chem. Soc., Perkin Trans. I* **1993**, (23), 2857-2859; (b) Marmsater, F. P.; Vanecko, J. A.; West, F. G., *Tetrahedron* **2002**, *58* (10), 2027-2040.
48. Ye, T.; McKerverve, M. A., *Chem. Rev.* **1994**, *94* (4), 1091-1160.
49. Hata, Y.; Watanabe, M., *Tetrahedron Lett.* **1972**, *13* (46), 4659-4660.
50. Garcia-Valverde, M.; Pedrosa, R.; Vicente, M., *Synlett* **2002**, (12), 2092-2094.
51. Yijima, C.; Hino, F.; Suda, K., *Synthesis* **1981**, (8), 610-611.
52. Osipov, S. N.; Sewald, N.; Kolomiets, A. F.; Fokin, A. V.; Burger, K., *Tetrahedron Lett.* **1996**, *37* (5), 615-618.

Chapter 3

Studies toward the use of Azetidine Derivatives for the Synthesis of Bicyclic Heterocycles

3.1. Introduction

Our successful investigation into the ring expansion of azetidines (**1**) to pyrrolidines (**3**) *via* the Stevens rearrangement of azetidinium ylides, which was discussed in Chapter 2,¹ demonstrated that this methodology had potential to be used toward the synthesis of more complex frameworks, such as those found in alkaloid natural products.

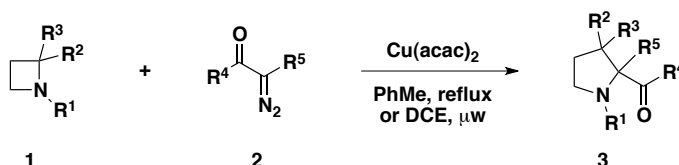

Scheme 3.1: Ring expansion of azetidines to pyrrolidines *via* the Stevens [1,2]-shift.

Previous work in our group had also shown that both medium-sized heterocycles² and the pyrrolizidine framework³ were both accessible using a Stevens [1,2]-shift approach. In 1994, West and Naidu reported the synthesis of azapinone and azocinone derivatives (**5**) from the intramolecular [1,2]-shift of acyclic amino-tethered diazoketones **4** (Scheme 3.2). In this case, the use of a homogenous copper catalyst, Cu(acac)₂, was found to be superior to Rh₂(OAc)₄ for the formation of the larger ring systems.

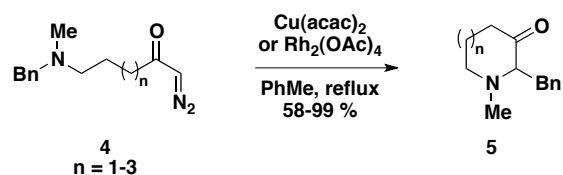

Scheme 3.2: Synthesis of aza-heterocycles *via* an intramolecular Stevens [1,2]-shift.

In 2005, West and Vanecko reported the synthesis of two alkaloid natural products, turneforicidine and platynecine, *via* the ring expansion of diazo-tethered azetidine **6**. The expansion of the *in situ* formed spirocyclic ammonium ylide **I** resulted in the formation of a 3.6 to 1 ratio of diastereomers **7** and **8**. After separation, these two compounds were carried forward separately to give the natural products turneforicidine (**9**) and platynecine (**10**, Scheme 3.3).

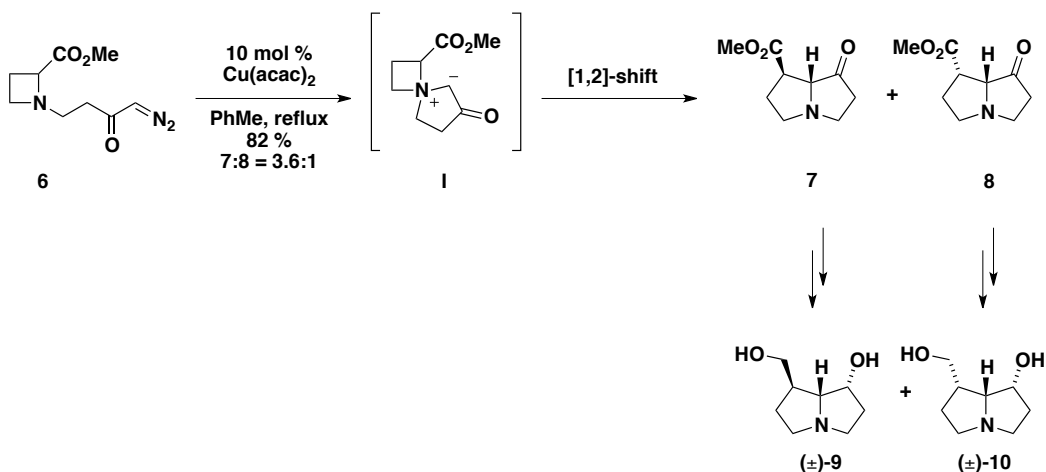

Scheme 3.3: Synthesis of the pyrrolizidine alkaloids turneforicidine and platynecine.

With the success of our earlier investigation and the precedent set by previous group members, we were confident in our abilities to combine these two ring-forming strategies for the formation of bicyclic systems possessing a medium-sized ring. There are several interesting alkaloid natural products that possess a 5,7- or 5,8-ring system that we believed would be accessible by this approach. The *stemon* alkaloids, for example stemonamine (Figure 3.1),⁴ are a diverse class of naturally occurring compounds possessing a 5,7-ring system at

their core. The 5,8-system, our other target, is present in natural products such as nakadomarin A.

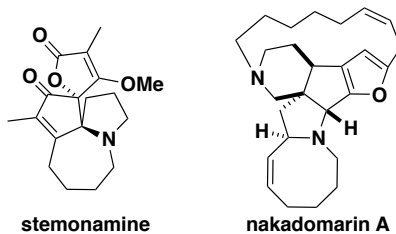
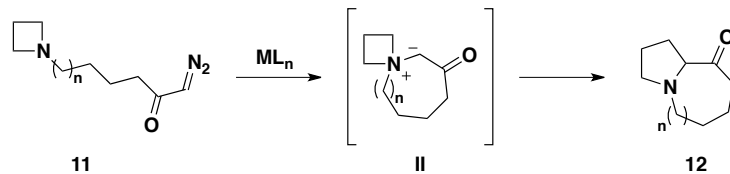

Figure 3.1: Natural products containing our target 5,7- or 5,8-ring system.

3.2. Studies Toward the Ring Expansion of Spirocyclic Azetidinium Ylides

Our first goal for this project was to determine if the ring expansion would occur with an azetidine ring possessing no radical stabilizing substituents on the α -carbons of the ring (Scheme 3.4). From our previous work, we knew that the release of strain in an azetidine ring was a strong driving force for the ring expansion of azetidines to pyrrolidines. We also knew that the reactivity of azetidines with no radical-stabilizing substituents on the α -carbon was different for a mono- and distabilized metallocarbene partners (Scheme 3.5). The ring expansion of *N*-benzylazetidine (**13**) to pyrrolidines (**14**) was successfully achieved when it was allowed to react with a metallocarbene derived *in situ* from a mono-stabilized diazocarbonyl compound and $\text{Cu}(\text{acac})_2$. When **13** was allowed to react with a distabilized metallocarbene, on the other hand, the product obtained was that from a [1,2]-benzyl shift (**15**). Although these examples led us to choose a monostabilized diazo-tether for our intramolecular variant we were still not sure how the system would behave with the formation of a spirocyclic ammonium ylide. If successful, this reaction would allow access to unsubstituted pyrrolidine frameworks, seen in molecules like stemonamine, without having to subsequently remove a directing group on the 2-position.



Scheme 3.4: Ring expansion of a diazo-tethered azetidine via a spirocyclic azetidinium ylide.

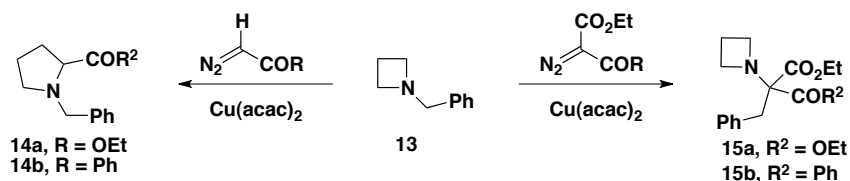

Scheme 3.5: Reactivity of *N*-benzylazetidine with differently stabilized diazocarbonyl compounds.

Access to the desired diazo-tethered azetidine **18** was accomplished by the alkylation of azetidine with the bromo-tethered diazocarbonyl compound **17**.² As azetidine itself is a rather expensive, volatile molecule we first set out to find a way to efficiently access the material on a large scale using readily available, relatively inexpensive starting materials. We were able to accomplish this by synthesizing *N*-benzhydrylamine (**16**), a stable white solid at room temperature, using a modified version of a procedure reported by Causey and coworkers.⁵ *N*-benzhydrylamine (**16**) was subsequently debenzylated, under transfer hydrogenation conditions, and alkylated with bromo-tethered diazo compound **17** in the presence of triethylamine. Unfortunately, all attempts to induce the desired [1,2]-ring expansion of **18**, in the presence of copper or rhodium catalysts, only led to the formation of azocane **19**.

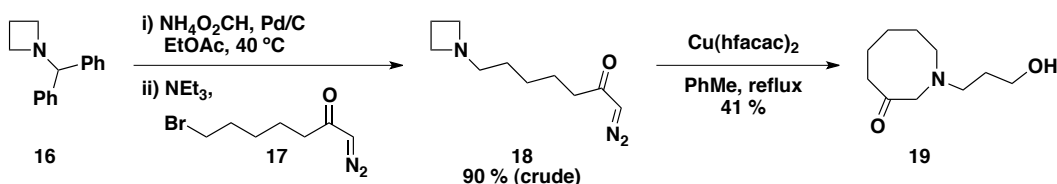

Scheme 3.6: Synthesis of azocane **19**.

Azocane **19** was believed to arise from ring opening of the intermediate ylide (**III**) with water (Scheme 3.7). All attempts to remove any superfluous water from the starting substrate were not successful in preventing the formation of the azocane **19** or inducing the formation of the desired product **20**. It is possible that the ylide intermediate **III**, formed through attack on the electrophilic carbenoid with nitrogen, is not reactive enough under these conditions to undergo the desired transformation.

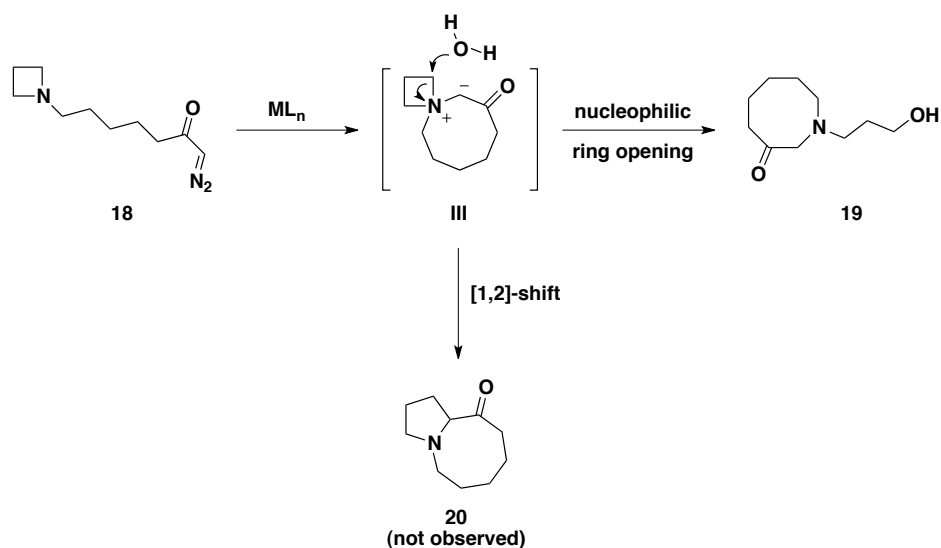

Scheme 3.7: Mechanism for the generation of azocane 19.

Given the absence of any evidence for the desired ring expansion using a nonstabilized azetidine substrate, we next turned to the use of stabilizing groups that could be placed in the α -carbon, which could lower the barrier for [1,2]-shift but could, if necessary, be subsequently removed. Installation of a ring carbonyl at the 2-position (i.e.; a β -lactam) was intriguing for a few reasons. First, the synthesis of β -lactams is well established in the literature and could allow us to access bi- or tricyclic ring systems quite quickly. Second, there were no reported examples of acyl radicals migrating during a [1,2]-shift reaction even though the stability of an acyl radical is reported in the literature to be very similar to that of a benzyl radical.⁶ Under the right conditions, such as the desire to release ring strain, we believed that an acyl [1,2]-shift was feasible (Scheme 3.8).

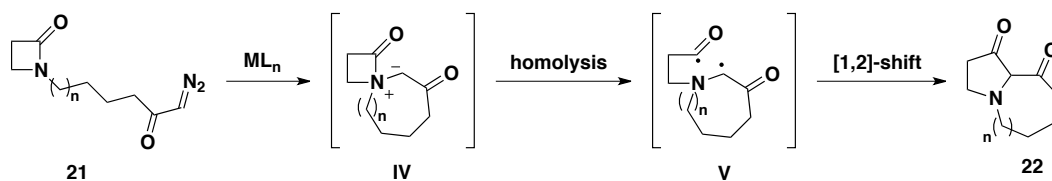

Scheme 3.8: Proposed [1,2]-acyl shift of β -lactams.

3.2.1. Studies toward the use of β -Lactams in the Stevens [1,2]-shift

The synthesis of β -lactams **25** and **28** was accomplished by a [2+2]-cycloaddition between cyclohexene (**23**) or styrene (**27**) and chlorosulfonyl isocyanate (**24**).⁷ Subsequent alkylation with either benzyl bromide or butyl bromide under phase transfer conditions⁸ gave the desired compounds **26** and **29** (Scheme 3.9). We chose these substrates to not only investigate the possibility of the ring expansion taking place, but to also see if there would be competition between [1,2]-acyl and [1,2]-benzyl migration.

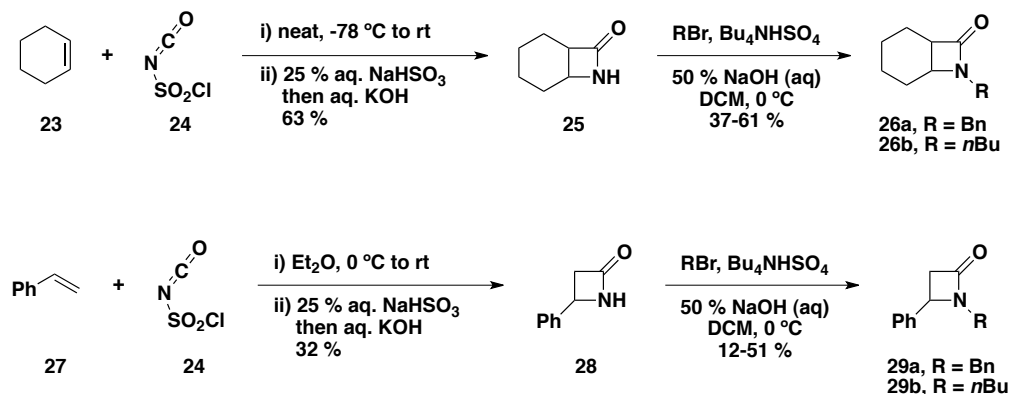

Scheme 3.9: Synthesis of β -lactam substrates.

Following a procedure we developed for the ring expansion of azetidines to pyrrolidines we first tried the slow addition of either ethyl diazoacetate (**30a**) or diethyl diazomalonate (**30b**) to a solution of the β -lactam (**26** or **29**) and a copper catalyst in toluene at reflux (Scheme 3.10). In most cases, the crude reaction mixtures contained unreacted β -lactam starting material as well as diazocarbonyl

derived homodimers (**31**). Attempts at increasing the reaction temperature using microwave irradiation were also unsuccessful, resulting in both recovered starting material, homodimers and, when heated to high temperatures for prolonged periods of time, decomposition.

The lack of any reactivity in these experiments was a bit puzzling. Although we were aware that an equilibrium between ylides derived from both the amide nitrogen and the amide carbonyl was possible, we predicted that the ammonium ylide (**VII**) should be more thermodynamically favoured (Scheme 3.11). This prediction was based on work done by both the Padwa group⁹ and the Kappe group,¹⁰ which demonstrated that ammonium ylides (**IX**) derived from both amides **33** and ureas **34** were formed preferentially over their carbonyl ylide counterparts (**X**) (Scheme 3.12).

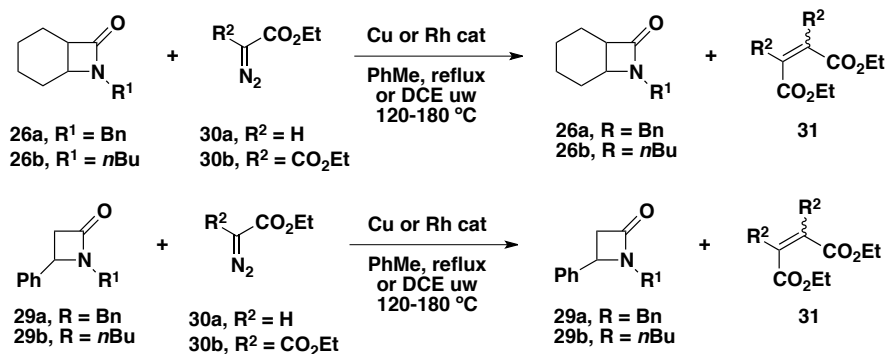

Scheme 3.10: Attempted Stevens [1,2]-shift of β -lactams with *in situ* derived metallocarbenes.

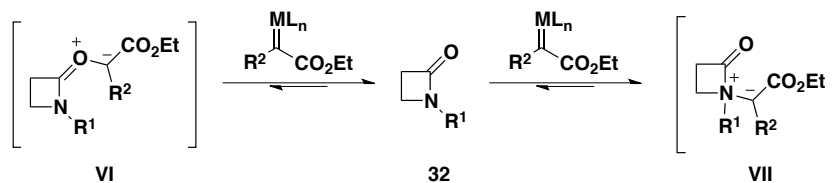

Scheme 3.11: Equilibrium between carbonyl and ammonium ylides.

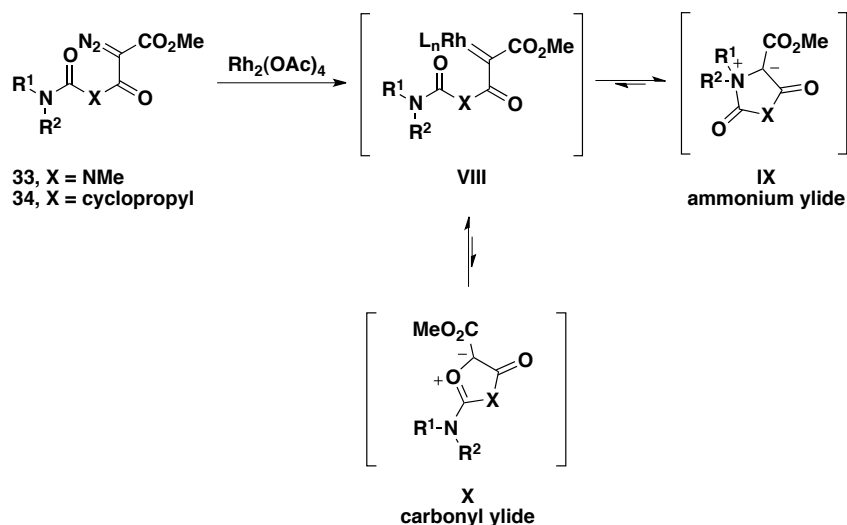

Scheme 3.12: Precedent for preferential ammonium ylide formation.

In our case, where the amide nitrogen is most likely more basic than a typical unstrained amide due to decreased contribution by the zwitterionic amide resonance form in the strained four-membered ring, coordination with the *in situ* generated metallocarbene should be possible. Even if none of our desired [1,2]-ring expansion products were formed we still expected to see either a [1,2]-benzyl shift, in the case of **26a** and **29a**, or α' , β -fragmentation, in the case of **26b** and **29b** (Scheme 3.13). The fact that none of these products was observed made us wonder if the ammonium ylide was being generated at all. Given this uncertainty and the limited time remaining, we chose at this point to examine other approaches to “temporary stabilization” at C-2.

In lieu of an acyl migrating group, we next turned to the use of a silyl group for stabilizing the [1,2]-shift. In 2002, West and Vanecko reported a novel silyl-directed Stevens rearrangement as the key step in the synthesis of quinolizidine derivatives (Scheme 3.14).¹¹ This synthesis, which utilized established chemistry for the asymmetric α -lithiation of *N*-Boc pyrrolidine,¹² resulted in the formation of dihydroxyquinolizidines **43a** and **43b** in six steps from readily available *N*-Boc pyrrolidine (**38**).

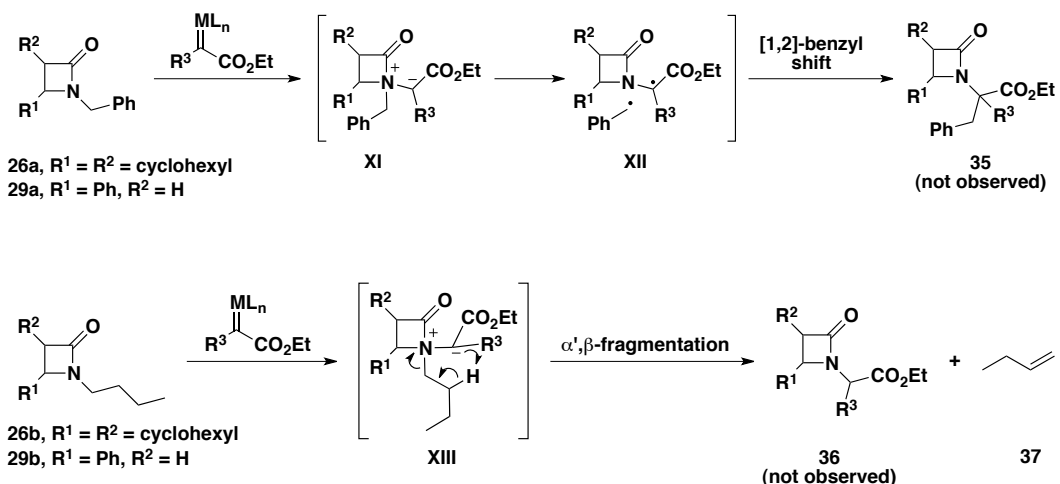

Scheme 3.13: Possible reaction pathways after generation of an ammonium ylide.

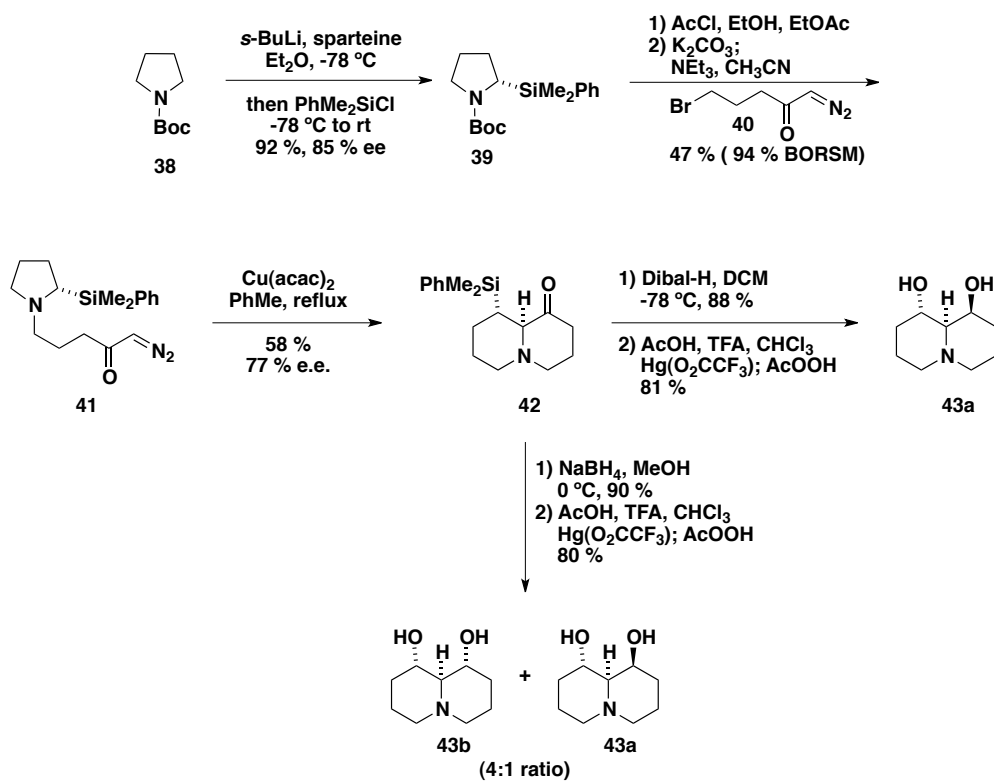

Scheme 3.14: Synthesis of dihydroxyquinolizidines *via* a silyl-directed [1,2]-shift.

3.2.2. Studies Toward Asymmetric α -Lithiation of Azetidines

Our first objective for this project was to determine if the α -lithiation chemistry developed in the Beak group would work with *N*-Boc azetidine.¹² The success of the Beak methodology is due to the formation of a *s*-BuLi/(-)-sparteine complex (Li^*) which coordinates with the oxygen of the Boc-protecting group before for deprotonation (Scheme 3.15). This deprotonation provides an enantiomerically enriched organolithium intermediate (**XIV**) which subsequently undergoes stereoselective electrophilic substitution to generate the desired product (**44**). We hoped that a similar result would work for our case as well.

The synthesis of *N*-Boc azetidine (**45**) was accomplished in two steps from *N*-benzhydrylazetidine (**16**, Scheme 3.16). Removal of the benzhydryl group *via* transfer hydrogenation, followed by filtration of the reaction mixture to remove the catalyst and subsequent addition of di-*tert*-butyl dicarbonate (Boc_2O) and aqueous sodium hydroxide, resulted in the formation of *N*-Boc azetidine (**45**) in 79% yield.

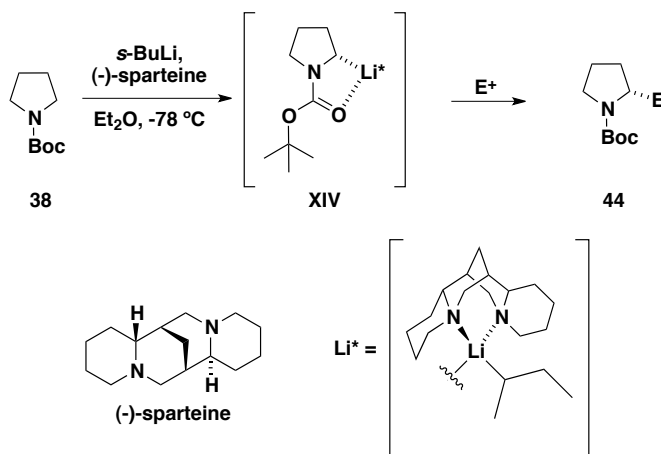

Scheme 3.15: Asymmetric α -lithiation/electrophilic substitution of *N*-Boc pyrrolidine.

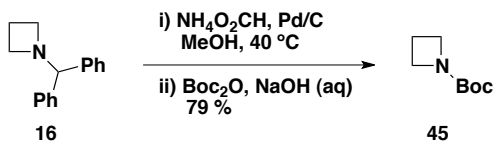

Scheme 3.16: Synthesis of *N*-Boc azetidine.

With the desired substrate in hand we next set out to determine if α -lithiation using the Beak methodology was possible for the generation of the α -silylated azetidine **46**. We began by treating N-Boc azetidine **45** with *s*-BuLi in the presence of tetramethylethylenediamine (TMEDA) in Et₂O at -78 °C followed by addition of freshly distilled TMSCl (Table 3.1, entry 1). The procedure was similar to those reported for the synthesis of asymmetric N-Boc pyrrolidines; however, instead of using (-)-sparteine we used TMEDA with a goal of first optimizing the formation of racemic product using a less expensive diamine ligand.

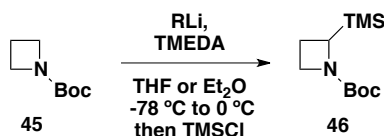

Entry	RLi (equiv) ¹	Solvent	Temp (°C)	Time (h) ²	Yield 46 (%)
1	<i>s</i> -BuLi (1.3)	Et ₂ O	-78 °C	6	- ³
2	<i>s</i> -BuLi (1.3)	Et ₂ O	-78 °C	8	- ³
3	<i>s</i> -BuLi (1.3)	Et ₂ O	-78 °C	2	- ³
4	<i>s</i> -BuLi (1.3)	Et ₂ O	-45 °C	6	- ³
5	<i>s</i> -BuLi (1.3)	THF	-78 °C	6	- ³
6	<i>n</i> -BuLi (1.3)	Et ₂ O	-78 °C	6	- ³
7	<i>t</i> -BuLi (1.3)	Et ₂ O	-78 °C	6	- ³

¹The equivalents of TMEDA were the same as those reported for RLi relative to 1 equiv of **45**.

²Refers to the time RLi was allowed to react with the substrate (**45**) before addition of TMSCl.

³Mostly recovered starting material by ¹HNMR analysis of crude reaction mixture.

Table 3.1: Survey of condition employed for the attempted α -lithiation/silylation of N-Boc azetidine.

Unfortunately, this standard procedure failed to afford any of the desired α -silylated material. Table 3.1 shows a representative example of the modifications to the standard conditions we tried to provide the desired α -silylated product **46**. In our hands, none of the changes of solvent (THF vs. Et₂O), organolithium reagent (*n*-BuLi, *s*-BuLi, *t*-BuLi), reaction temperature (-78 °C to 0 °C) or reaction time was successful in helping us to obtain the desired compound.

Fortuitously, during our struggles with this lithiation approach, the Hodgson group published a timely report on the lithiation and electrophilic substitution of N-thiopivaloylazetidine (Scheme 3.17).¹³ In their report, the authors described the difficulties they had encountered in attempting to α -lithiate *N*-Boc azetidine as well as other *N*-protected azetidine derivatives. In the end, they found that the thiopivaloyl group was the key to successful lithiation and ultimately, electrophilic substitution.

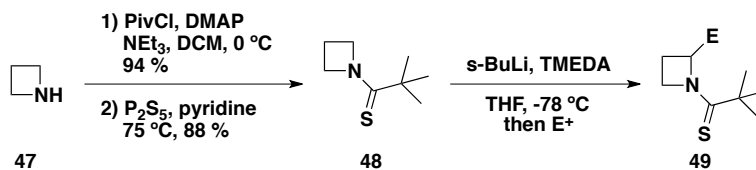

Scheme 3.17: Successful α -lithiation/electrophilic substitution of N-thiopivaloylazetidine.

With a clear route to our desired substrate in hand we went forward and synthesized the α -silylated azetidine derivative **51** (Scheme 3.18). As with our *N*-Boc azetidine substrate described previously, we were able to access the pivaloyl-protected azetidine **50** using a two-step protocol from *N*-benzhydrylamine (**16**). Conversion of **50** to the desired thiopivaloyl-protected substrate (**48**) was accomplished using either the P₂S₅/pyridine conditions reported in the Hodgson paper or by treatment with Lawesson's reagent in refluxing THF. Subsequent application of the α -lithiation/electrophilic substitution protocol provided the α -silylated product **51** in excellent yield. With the desired substrate finally in hand, our next step was the removal of the thiopivaloyl protecting group in order to gain access to the free azetidine (**52**) for further transformations.

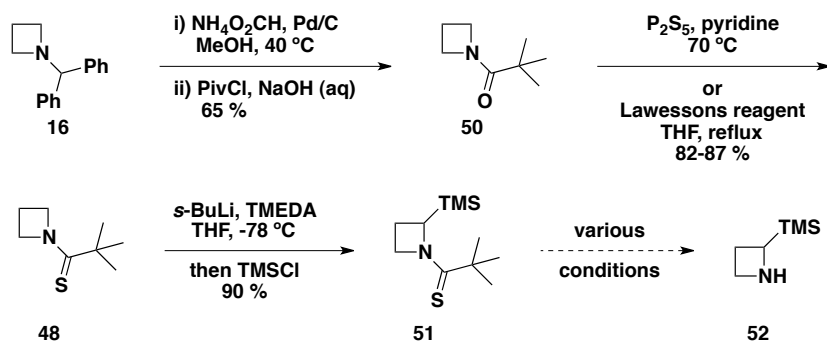

Scheme 3.18: Synthesis of α -silylated azetidine derivative **51**.

Removal of the thiopivaloyl group, however, was a much harder endeavor than we had expected. In their paper, the Hodgson group reported the removal of the thiopivaloyl protecting group from azetidine **53**, possessing a benzyl substituent on the α -position, by the addition of five equivalents of methyllithium followed by treatment of acid to form the HCl salt (**52**) or as the HCl salt (**55**). Unfortunately, a thorough search through the literature for other methods to remove the protecting group was of little help, as there are very few examples of the removal of thiopivaloyl groups reported.¹⁴ Table 3.2 shows a small example of different conditions we tried in an attempt to remove the unwanted protecting group. In most cases the starting material was completely consumed; however, we were not able to identify the components of the complex mixture of polar products that ensued.

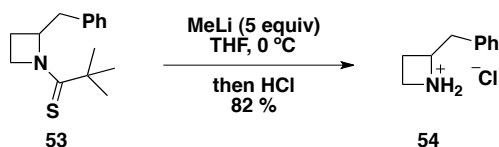

Scheme 3.19: Removal of thiopivaloyl protecting group from **53**.

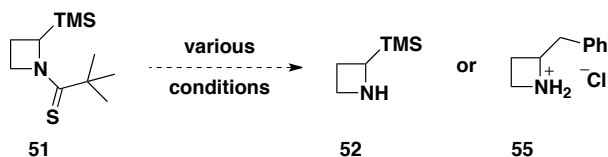

Entry	Conditions	Product
1	MeLi (5 equiv) THF, -78 °C then HCl	complex mixture
2	MeLi (5 equiv) THF, 0 °C then HCl	complex mixture
3	MeLi (2 equiv) THF, -78 °C then NH ₄ Cl (aq)	complex mixture + Recovered SM
4	MeLi (1 equiv) THF, -78 °C then NH ₄ Cl (aq)	mostly recovered SM
5	 reflux	complex mixture

Table 3.2: Conditions used in an attempt to remove the thiopivaloyl protecting group.

At this point, we were concerned that the problems we were encountering were due to the TMS group being too labile for these reaction conditions. To test for this we decided to try the MeLi thiopivaloyl strategy again, only this time we quenched the reaction with Boc₂O instead of a proton source. To our delight, we were able to isolate the desired α -silylated *N*-Boc protected azetidine in 59% yield (Scheme 3.20).

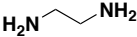
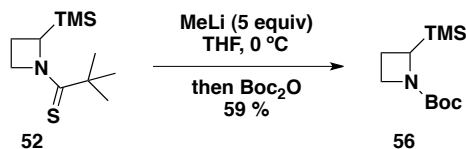

Scheme 3.20: Successful replacement of the thiopivaloyl group on 51 with a Boc group.

With the success of the Boc-azetidine derivative (**56**) in hand we chose to synthesize the dimethylphenylsilyl (DMPS) azetidine derivative **57**. We believed

that the DMPS group would not only be better at withstanding the deprotection conditions but would also give us better control over the diastereoselectivity in our subsequent Stevens [1,2]-shift applications. At this point we also decided to look into the use of (-)-sparteine as a way to generate the desired compound in enantiomerically enriched form. Interestingly, when we tried the α -silylation using 3 equivalents of DMPSCI, as we had with TMSCl in our previous case (see Scheme 3.18), we found that our major product was one derived from the incorporation of two DPMS groups. Subsequent optimization of the reaction conditions revealed that the best results were achieved when the reaction was performed in Et₂O with only 1.2 equivalents of DMPSCI (Scheme 3.).

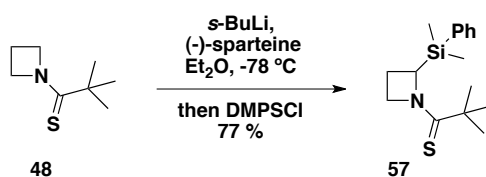

Scheme 3.21: Synthesis of the α -DMPS-azetidine derivative **57**.

The removal of the thiopivaloyl group, using the MeLi/Boc₂O conditions that had been successful in the case of the TMS-azetidine derivative **52** (see Scheme 3.20), again proved to be temperamental. Although we were able to obtain small amounts of the Boc-protected product (**58**), the reaction was found to be quite capricious and in most cases we also isolated both recovered starting material and dimethylphenylsilanol (**59**) as side products (Scheme 3.22).

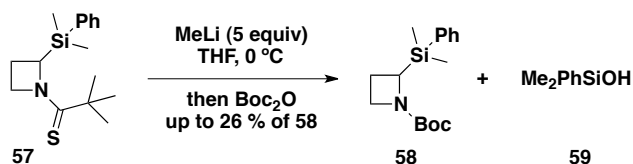

Scheme 3.22: Replacement of the thiopivaloyl group on **57** with a Boc group.

As an alternative approach to the removal of this rather intractable thiopivaloyl protecting group we decided to see if converting it to the thioimide

salt (**60**), which should then be susceptible to hydrolysis, would give us access to the desired free azetidine (**61**). The thioimidate salt was prepared by treatment of **57** with methyl triflate in DCM (Scheme 3.23). Surprisingly, after quenching the reaction with either water or 1 M HCl followed by a subsequent acid/base extraction workup procedure we found that the thioimidate salt (**60**) was still intact. In the literature thioimidate derivatives are prepared *in situ* for direct use in successive reactions, as they are generally quite sensitive to hydrolysis. Our substrate, on the other hand, seemed to be quite stable through both aqueous and weakly acidic workup conditions as well as exposure to oxygen. Subsequent attempts to hydrolyze **60** to the free azetidine resulted in either recovered starting material, the isolation of dimethylphenylsilanol (**59**), in reactions using strongly acidic conditions, or in the isolation of the pivaloyl-protected derivative **62**, when treated under basic conditions (Table 3.3).

The generation of the pivaloyl derivative **62** seemed to be the only useful reactivity achieved when trying to hydrolyze **60**. At that time it became obvious that it would be easier to obtain **62** by treating the original α -silylated thiopivaloylazetidine **57** with H₂O₂ and acetic acid. This procedure cleanly converted **57** to **62** in 68 % yield (Scheme 3.24).

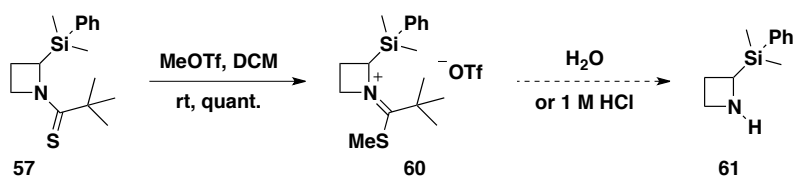

Scheme 3.23: Synthesis of a stable thioimidate salt from azetidine **57**.

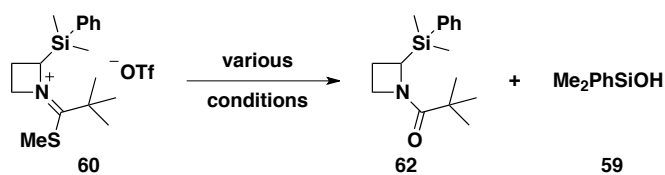

Entry	Conditions	Product
1	6M HCl, MeOH	59
2	1M HCl	SM + 59
3	$\text{H}_2\text{O}/\text{CH}_3\text{CN}$	recovered SM
4	NaBH_4 , NaOH $\text{H}_2\text{O}/\text{DMF}/\text{MeOH}$	complex mixture
5	1M NaOH (aq)	62
6	1M NaOH, CH_3CN	62

Table 3.3: Conditions for the attempted hydrolysis on thioimidate salt 60.

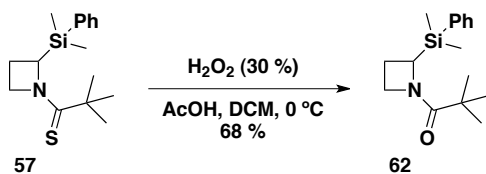

Scheme 3.24: Oxidation of thiopivaloyl azetidine 57 to pivaloyl azetidine 62.

We are hopeful that the removal of the pivaloyl protecting group from **62** will be a more successful approach to accessing the free azetidine than the removal of the thiopivaloyl protecting group from **57**. One method that we think holds promise is the naphthalene-catalyzed lithiation protocol reported in 2006 by Yus and coworkers (Scheme 3.25).¹⁵ Unlike the harsh methods of attacking the amide carbonyl with a strong base, which are most commonly employed, this approach allows for removal of the pivaloyl group under very mild conditions.

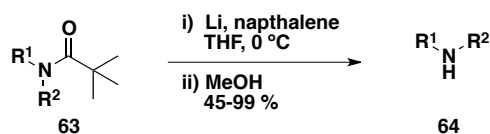

Scheme 3.25: Napthalene-catalyzed lithiation protocol for the deprotection of amides.

With successful removal of the protecting group, the next step in this project will be to confirm the directing ability of the silyl group during the Stevens [1,2]-shift. Alkylation of the free amine **65** with butyl bromide or benzyl bromide would generate test substrates **66a** and **66b**, which would subsequently be allowed to react in an intermolecular fashion with the metallocarbene derived *in situ* from ethyl diazoacetate and a copper catalyst. Our prediction is that these azetidine derivatives will preferentially undergo ring expansion to the pyrrolidine derivatives **67a** and **67b**.

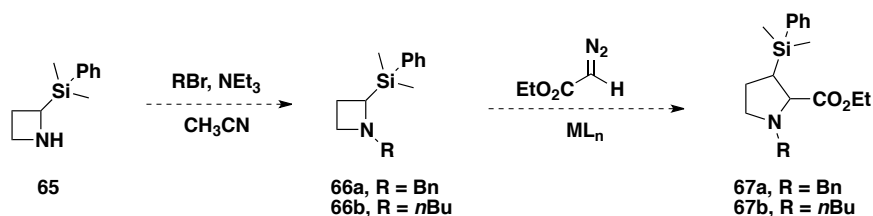

Scheme 3.26: Proposed strategy to access pyrrolidines **67**.

3.3. Conclusion

The ability to access heterocyclic frameworks, like those found in alkaloid natural products, by using different methodologies is very important. The Stevens rearrangement of azetidinium ylides, which has been demonstrated to be a versatile method for accessing pyrrolidine and pyrrolizidine frameworks, was the methodology we wanted to expand for this purpose. One of the key features of azetidinium ylides is their ability to undergo ring expansion to pyrrolidines preferentially over other pathways. This preference is driven by the favourable release of ring strain in these systems. The intent of this project was to investigate

the Stevens [1,2]-shift of spirocyclic azetidinium ylides possessing either no radical stabilizing substituents on the α -carbons or radical stabilizing substituents that could subsequently be removed. Unfortunately, we were unable to access the desired ring expansion products from the unstabilized system of the carbonyl-stabilized system. The use of a silyl-directed Stevens rearrangement, where the silyl group can subsequently be converted to other functional groups, was another avenue that we chose to explore. This methodology has the potential for asymmetric synthesis of the desired targets. Access to the α -silylated azetidine derivatives was successful; however, subsequent removal of the protecting groups on nitrogen remains a challenge.

3.4. Future Directions

With the ability to access the desired α -silylated azetidines in hand, the next step in this project will be the removal of the pivaloyl protecting group followed by alkylation of the free azetidine to provide substrates amenable to the Stevens [1,2]-shift (Scheme 3.). If the rearrangements are successful in the intermolecular case this methodology will be extended to the intramolecular ring expansion of **68** to access the 5,7- and 5,8-frameworks (**69**).

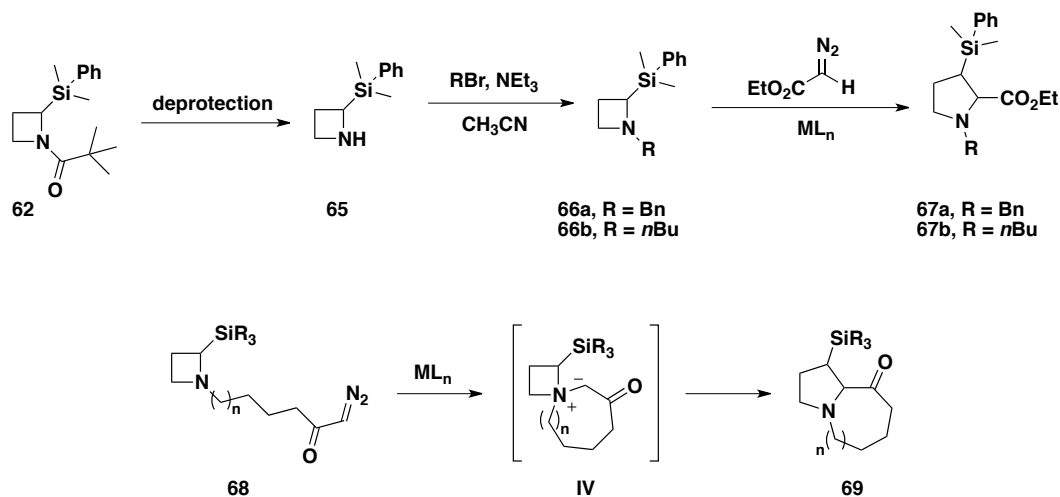

Scheme 3.27: Inter- and intramolecular silyl-directed ring expansion of azetidinium ylides.

One of the aspects of this methodology that makes it so attractive is the potential to generate enantiomerically enriched starting materials simply and efficiently. The second portion of this project will focus on determining the best way of achieving excellent enantioselectivity by the addition of various chiral ligands (e.g. 70-72).

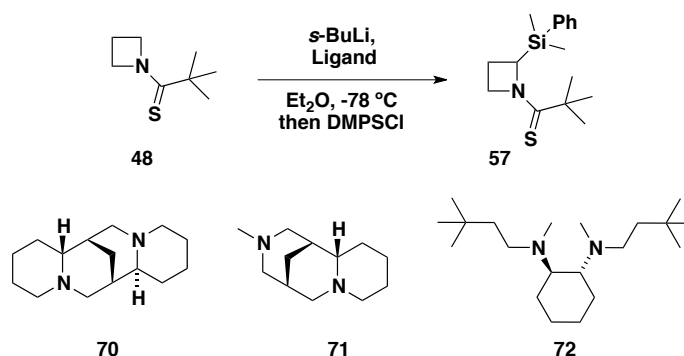

Scheme 3.28: Optimization of enantioselective α -lithiation/silylation protocol.

3.5. Experimental

3.5.1. General Information

Reactions were carried out in oven (130 °C) or flame-dried glassware under a positive argon atmosphere unless otherwise stated. Transfer of anhydrous reagents was accomplished with oven-dried syringes or cannulae. Solvents were distilled before use: acetonitrile (CH_3CN), dichloroethane (DCE), dichloromethane (DCM) and ethyl acetate (EtOAc) from calcium hydride, diethyl ether (Et_2O), tetrahydrofuran (THF) and toluene (PhMe) from sodium metal. Pyridine, triethylamine (NEt_3), tetramethylethylenediamine (TMEDA), (-)-sparteine, trimethylsilyl chloride (TMSCl) and dimethylphenylsilyl chloride (DMPSCI) were distilled over calcium hydride before use. Alkyl lithium reagents were titrated before use by deprotonation of a known quantity of menthol in the presence of 1,10-phenanthroline as the indicator. Microwave heating was carried out in a Biotage Initiator microwave reactor, using 2-5 mL microwave vials.

Reaction temperature was determined through measurement of the vial surface temperature using an infrared sensor, then corrected for internal temperature by the unit's processor using a proprietary algorithm. Thin layer chromatography was performed on glass plates pre-coated with 0.25 mm silica gel with fluorescent indicator UV₂₅₄ (Rose Scientific). Flash chromatography columns were packed with 230-400 mesh silica gel (Silacyle). β -lactams **25** and **28** were prepared using literature procedures⁷ and alkylated following the method reported by Parsons and coworkers⁸ to provide known compounds **26a/b** and **29a/b**.

3.5.2. Characterization

7-(Azetidin-1-yl)1-diazo-2-heptanone **18**:

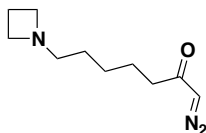

A solution of 7-bromo-1-diazo-2-heptanone **17**² (269 mg, 1.22 mmol) in CH₃CN (6.3 mL) was transferred *via* cannula into a flask containing a solution of azetidine (170 μ L, 2.53 mmol) and CH₃CN (12.6 mL). Triethylamine (200 μ L, 1.43 mmol) was subsequently added to the reaction mixture before stirring overnight at room temperature. Removal of the solvent and excess amines under reduced pressure afforded crude yellow oil, which was dissolved in DCM and washed with equivalent portions of 1M NaOH (aq), water and brine. The organic layers were then dried over MgSO₄, filtered and concentrated under reduced pressure. The crude material was used without further purification.

18: isolated as a crude yellow oil; $R_f = 0.17$ (9:1 DCM:MeOH); IR (cast film) 2993, 2926, 2857, 2814, 2099, 1640, 1474 cm⁻¹; ¹H NMR (500 MHz, CDCl₃) $\delta = 5.25$ (br s, 1H), 3.18 (t, $J = 7.0$ Hz, 4H), 2.34 (app t, $J = 7.0$ Hz, 2H), 2.33 (br s, 2H), 2.08 (p, $J = 7.0$ Hz, 2H), 1.67-1.64 (m, 2H), 1.37-1.34 (m, 4H); ¹³C NMR (125 MHz, CDCl₃) $\delta = 195.0, 59.7, 55.2, 54.2, 40.9, 27.3, 26.9, 25.1, 17.7$; HRMS calc'd for C₁₀H₁₈N₃O [M+H]⁺ 196.1444, found 196.1444.

1-(3-hydroxypropyl)azocane-3-one **19**:

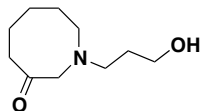

A solution of compound **18** (57 mg, 0.29 mmol) in PhMe (2.9 mL) was added to a solution of Cu(hfacac)₂ (13 mg, 0.03 mmol) in PhMe at 80 °C over a 12 h period *via* syringe pump. Once the addition was complete the syringe containing the solution of compound **18** was rinsed with 1 mL of PhMe. After an additional 15 min at 80 °C the reaction was allowed to cool to room temperature. The reaction mixture was washed with equivalent portions of 0.5 M K₂CO₃ (aq) and brine, dried over MgSO₄, filtered and concentrated under reduced pressure. Flash chromatography (silica gel, gradient from 7:3 hexanes:EtOAc to 1:9 hexanes:EtOAc) resulted in the isolation of 22 mg (41 %) of **19** as a yellow oil.

19: R_f = 0.58 (1:9 MeOH:EtOAc); IR (cast film) 3422, 2929, 2860, 2806, 1706 cm⁻¹; ¹H NMR (500 MHz, CDCl₃) δ = 3.84 (t, *J* = 5.8 Hz, 2H), 3.53 (br s, 1H), 3.04 (s, 2H), 2.69 (t, *J* = 6.1 Hz, 2H), 2.59 (dd, *J* = 6.1, 6.5 Hz, 2H), 2.55 (t, *J* = 6.1 Hz, 2H), 1.77 (p, *J* = 5.8 Hz, 2H), 1.73 (app p, *J* = 6.0 Hz, 2H), 1.64 (app p, *J* = 5.6 Hz, 2H), 1.39 (m, 2H); ¹³C NMR (125 MHz, CDCl₃) δ = 217.1, 67.2, 63.2, 58.7, 58.0, 39.7, 29.9, 28.9, 26.3, 25.8; HRMS calc'd for C₁₀H₂₀NO₂ [M+H]⁺ 186.1489, found 186.1491.

tert-Butyl azetidine-1-carboxylate **45**:



To a solution of *N*-benzhydrylazetidine⁵ (1.25g, 5.5 mmol), ammonium formate (1.08g, 17 mmol) and MeOH (25 mL) was added Pd/C (2.5g, 10 % active, 50 % wet). The reaction was heated to a gentle reflux and monitored for loss of starting material by TLC (ca. 10 min). After cooling to 0 °C the reaction mixture was filtered through a bed of celite into a clean flask. The celite pad was rinsed with

several portions of MeOH (3x25 mL) and the combined organic layers were cooled to 0 °C before addition of 1M NaOH (aq, 6 mL) and Boc₂O (1.4 mL, 6.7 mmol). The reaction was stirred from 0 °C to room temperature overnight then concentrated under reduced pressure to remove MeOH. The remaining solution was diluted with water (10 mL) and extracted with DCM (3x 25 mL). The combined organic layers were washed with brine, dried over MgSO₄ and concentrated under reduced pressure. Flash chromatography (silica gel, gradient from 1:9 EtOAc:hexanes to 3:7 EtOAc: hexanes) yielded 670 mg (79 %) of **45** as a colourless oil. The spectral data for **45** matched that reported in the literature.¹⁶

1-(azetidin-1-yl)2,2-dimethylpropan-1-one 50:

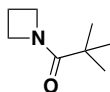

To a solution of N-benzhydrylazetidine⁵ (5.5g, 24 mmol), ammonium formate (4.5 g, 71 mmol) and MeOH (118 mL) was added Pd/C (5.5 g, 10 % active, 50 % wet). The reaction was heated to a gentle reflux and monitored for loss of starting material by TLC (ca. 10 min). After cooling to 0 °C the reaction mixture was filtered through a bed of celite into a clean flask. The celite pad was rinsed with several portions of MeOH (3x50 mL) and the combined organic layers were cooled to 0 °C before addition of 1M NaOH (aq, 24 mL) and PivCl (4.4 mL, 36 mmol). The reaction was stirred from 0 °C to room temperature overnight then concentrated under reduced pressure to remove MeOH. The remaining solution was diluted with water (50 mL) and extracted with DCM (3 x 50 mL). The combined organic layers were washed with brine, dried over MgSO₄ and concentrated under reduced pressure. Flash chromatography (silica gel, 1:1 EtOAc: hexanes) yielded 2.22 g (65 %) of **50** as a colourless oil. The spectral data for **50** matched that reported in the literature.¹³

***tert*-Butyl 2-(trimethylsilyl)azetidine-1-carboxylate **56**:**



A solution of methylolithium (820 μL , 1.15 M in Et_2O) was slowly added to a solution of **52**¹³ (53 mg, 0.23 mmol) in THF (16.7 mL) at 0 $^\circ\text{C}$. After addition of MeLi was complete the reaction was allowed to slowly warm to room temperature during which time the solution turned a bright yellow colour. The reaction mixture was cooled to 0 $^\circ\text{C}$ before the addition of Boc_2O (265 μL , 1.15 mmol) and a catalytic amount of DMAP. The reaction was stirred from 0 $^\circ\text{C}$ to room temperature overnight before being washed with equivalent portions of water and brine, dried over MgSO_4 , filtered and concentrated under reduced pressure. Flash chromatography (silica gel, gradient from 100 % hexanes to 9:1 hexanes:EtOAc) yielded 31 mg (59 %) of **56** as a colourless oil.

56: $R_f = 0.16$ (9:1 hexanes:EtOAc); IR (cast film) 2980, 2932, 1811, 1798, 1722, 1339, 1159 cm^{-1} ; ^1H NMR (500 MHz, CDCl_3) $\delta = 4.04$ (app q, $J = 6.6$ Hz, 1H), 3.99 (dd, $J = 7.3, 10.3$ Hz, 1H), 3.88 (dddd, $J = 0.8, 5.9, 8.9, 9.0$ Hz, 1H), 2.36-2.22 (m, 1H), 1.99 (dddd, $J = 6.3, 7.3, 9.0, 11.0$ Hz, 1H), 1.41 (s, 9H), 0.44 (s, 3H), 0.38 (s, 3H); ^{13}C NMR (125 MHz, CDCl_3) $\delta = 156.6, 79.0, 54.1, 53.4, 49.3, 28.6, 17.3, -3.7$; HRMS calc'd for $\text{C}_{10}\text{H}_{20}\text{NO}_2$ $[\text{M}+\text{Na}]^+$, found 194.1

1-(2-(dimethylphenylsilyl)azetidi-1-yl)-2,2-dimethylpropane-1-thione **57:**

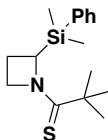

A solution of *sec*-butyllithium (5.09 mL, 1.2 M in cyclohexane) was slowly added to a solution of **48**¹³ (801 mg, 5.1 mmol) and (-)-sparteine (2.8 mL, 12.2 mmol) in Et_2O (30 mL) at -78 $^\circ\text{C}$. The reaction was allowed to stir at -78 $^\circ\text{C}$ for 15 min, warmed to 0 $^\circ\text{C}$, stirred for 15 min then re-cooled to -78 $^\circ\text{C}$. At this time the solution had become bright yellow in colour. Once cooled dimethylphenylsilyl

chloride (1.0 mL, 6.0 mmol) was added the reaction was warmed to 0 °C and the reaction was monitored for loss of starting material and product formation by TLC. Once the reaction was deemed complete (ca. 15 min) it was quenched with NH₄Cl (aq, 10 mL) then warmed to room temperature. The reaction mixture was diluted with water (10 mL) and extracted with DCM (3 x 25 mL). The combined organic layers were washed with brine, dried over MgSO₄, filtered and concentrated under reduced pressure to give a yellow oil. Flash chromatography (silica gel, 19:1 hexanes:EtOAc) resulted in the isolation of 1.14 g of **57** (77%) as a colourless oil that solidified upon standing to a crystalline solid.

57: R_f = 0.42 (9:1 hexanes:EtOAc); m.p. = 39-41 °C ; IR (neat film) 2965, 2902, 1469, 1440, 1248, 1135, 1112, 817 cm⁻¹; ¹H NMR (500 MHz, CDCl₃) δ = 7.56-7.54 (m, 2H), 7.37-7.33 (m, 3H), 4.77 (ddd, *J* = 2.2, 6.2, 10.8 Hz, 1H), 4.31 (ddd, *J* = 5.0, 9.8, 10.4 Hz, 1H), 4.09-4.03 (m, 1H), 2.31 (dddd, *J* = 7.2, 9.7, 10.9 Hz, 1H), 1.92 (dddd, *J* = 6.1, 9.1, 11.1 Hz, 1H), 1.22 (s, 9H), 0.56 (s, 3H), 0.48 (s, 3H); ¹³C NMR (125 MHz, CDCl₃) δ = 206.1, 136.8, 134.1, 129.3, 127.7, 61.5, 56.9, 42.7, 29.8, 17.3, -2.1, -2.1; HRMS calc'd for C₁₆H₂₆NSSi [M+H]⁺ 292.155, found 292.1549. Anal. calc'd for C₁₆H₂₅NSSi: C, 65.92; H, 8.64; N, 4.80; S: 11.00, found C, 65.91; H, 8.63; N: 4.78; S: 10.86.

tert-Butyl 2-(dimethylphenylsilyl)azetidine-1-carboxylate 58:

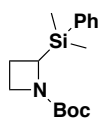

A solution of methyllithium (370 μL, 1.4 M in Et₂O) was slowly added to a solution of compound **57** (75 mg, 0.26 mmol) in Et₂O (10 mL) at 0 °C. After addition of MeLi was complete the reaction was allowed to slowly warm to room temperature during which time the solution turned a bright yellow colour. The reaction mixture was cooled to 0 °C before the addition of Boc₂O (300 μL, 1.3 mmol) and a catalytic amount of DMAP. The reaction was stirred from 0 °C to room temperature overnight before being washed with equivalent portions of

water and brine, dried over MgSO_4 , filtered and concentrated under reduced pressure. Flash chromatography (silica gel, 9:1 hexanes:EtOAc) yielded 20 mg (26 %) of **58** as a colourless oil.

58: $R_f = 0.42$ (9:1 hexanes:EtOAc); IR (neat film) 2964, 2931, 2884, 1695, 1455, 1478, 1427, 1404, 1249, 1124 cm^{-1} ; ^1H NMR (500 MHz, CDCl_3) $\delta = 7.56\text{--}7.52$ (m, 2H), 7.39–7.34 (m, 3H), 4.17 (dd, $J = 7.1, 10.4$ Hz, 1H), 3.96 (m, 1H), 3.70 (m, 1H), 2.26 (m, 1H), 1.94 (m, 1H), 1.41 (s, 9H), 0.44 (s, 3H), 0.38 (s, 3H); ^{13}C NMR (125 MHz, CDCl_3) $\delta =$ HRMS calc'd for $\text{C}_{16}\text{H}_{26}\text{NO}_2\text{Si}$ $[\text{M}+\text{H}]^+$ 292.1727, found 292.1730.

2-(Dimethylphenylsilyl)-1-(2,2-dimethyl-1-(methylthio)propylidene)azetidinium triflate salt 60:

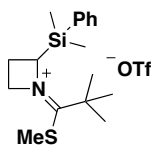

Methyl triflate (340 μL , 3.1 mmol) was added to a solution of **57** (454 mg, 1.56 mmol) in DCM (16 mL) at room temperature. The reaction was monitored by TLC analysis for consumption of starting material (ca. 5 min). Removal of the solvent under reduced pressure provided **60** as a thick oil (710 mg) in quantitative yield. The compound was used in subsequent reactions without purification.

60: IR (neat film) 3070, 3051, 2959, 1428, 1256, 1120, 1056, 832, 795 cm^{-1} ; ^1H NMR (500 MHz, CDCl_3) $\delta = 7.62\text{--}7.36$ (m, 5H), 5.45 (ddd, $J = 3.2, 5.7, 10.7$ Hz, 1H), 5.16 (ddd, $J = 4.8, 9.7, 12.6$ Hz, 1H), 4.50 (dddd, $J = 3.2, 7.5, 9.3, 12.6$ Hz, 1H), 3.23 (dddd, $J = 7.5, 9.7, 10.8, 10.7$ Hz, 1H), 2.73 (s, 3H), 2.28–2.21 (m, 1H), 1.23 (s, 9H), 0.70 (s, 3H), 0.57 (s, 3H). ^{13}C NMR (125 MHz, CDCl_3) $\delta = 191.2, 134.0, 133.0, 132.8, 131.1, 128.7, 127.7, 68.5, 64.5, 45.0, 27.9, 18.0, 17.9, -2.4, -4.6$; HRMS calc'd for $\text{C}_{17}\text{H}_{28}\text{NSSi}$ $[\text{M}]^+$ 306.1706, found 306.1710.

1-(2-(dimethylphenylsilyl)azetidin-1-yl)-2,2-dimethylpropan-1-one **62**:

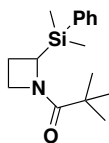

A solution of acetic acid (1 mL) and H₂O₂ (30 % wt in H₂O, 1.6 mL) was cooled to 0 °C before the addition of a solution of compound **57** (26 mg, 0.1 mmol) in DCM (300 μL). The reaction was stirred from 0 °C to room temperature overnight before cooling to 0 °C and quenching (Caution: dropwise!) with sat'd NaHSO₃(aq). The reaction mixture was extracted with DCM (3 x 5 mL) and the combined organic layers were washed with NaHCO₃ (aq, 2 x 10 mL), water (10 mL) and brine (10 mL), dried over MgSO₄, filtered and concentrated under reduced pressure. The colourless residue yielded 13 mg (69 %) of **62** that could be used without further purification.

62: R_f = 0.48 (7:3 hexanes:EtOAc); IR (neat film) 2957, 2902, 2879, 1615, 1480, 1420, 1245, 821 cm⁻¹; ¹H NMR (500 MHz, CDCl₃) δ = 7.58-7.56 (m, 2H), 7.39-7.35 (m, 3H), 4.33 (ddd, J = 6.3, 9.0 Hz, 1H), 4.26 (dd, J = 7.4, 10.5 Hz, 1H), 4.05 (ddt, J = 1.1, 6.4, 8.9 Hz, 1H), 2.26 (ddd, J = 6.1, 9.6, 10.8 Hz, 1H), 2.00 (dddd, J = 6.1, 7.3, 9.3, 11.0 Hz, 1H), 1.12 (s, 9H), 0.50 (s, 3H), 0.42 (s, 3H); ¹³C NMR (125 MHz, CDCl₃) δ = 176.5, 136.9, 134.2, 129.1, 127.7, 53.7, 53.1, 38.3, 27.2, 17.9, -3.7, -4.6; HRMS calc'd for C₁₆H₂₆NOSi [M+H]⁺ 276.1778, found 276.1778.

3.6. References

1. Bott, T. M.; Vanecko, J. A.; West, F. G., *J. Org. Chem.* **2009**, *74*, 2832-2836.
2. West, F. G.; Naidu, B. N.; Tester, R. W., *J. Org. Chem.* **1994**, *59*, 6892-6894.
3. Vanecko, J. A.; West, F. G., *Org. Lett.* **2005**, *7*, 2949-2952.
4. Pilli, R. A.; Rosso, G. B.; de Oliveira, M. d. C. F., *Natural Product Reports* **2010**, *27*, 1908-1937.

5. Causey, D. H.; Mays, R. P.; Shamblee, D. A.; Lo, Y. S., *Synth. Commun.* **1988**, *18*, 205-212.
6. Kerr, J. A., *Chem. Rev.* **1966**, *66*, 465-500.
7. (a) Forró, E.; Fülöp, F., *Tetrahedron: Asymmetry* **2001**, *12*, 2351-2358; (b) Viña, D.; Santana, L.; Uriarte, E.; Quezada, E.; Valencia, L., *Synthesis* **2004**, *2004*, 2517,2522.
8. Parsons, P. J.; Camp, N. P.; Mark Underwood, J.; Harvey, D. M., *Tetrahedron* **1996**, *52*, 11637-11642.
9. Curtis, E. A.; Worsencroft, K. J.; Padwa, A., *Tetrahedron Lett.* **1997**, *38*, 3319-3322.
10. Kappe, C. O., *Tetrahedron Lett.* **1997**, *38*, 3323-3326.
11. Vanecko, J. A.; West, F. G., *Org. Lett.* **2002**, *4*, 2813-2816.
12. (a) Kerrick, S. T.; Beak, P., *J. Am. Chem. Soc.* **1991**, *113*, 9708-9710; (b) Beak, P.; Kerrick, S. T.; Wu, S.; Chu, J., *J. Am. Chem. Soc.* **1994**, *116*, 3231-3239; (c) Beak, P.; Basu, A.; Gallagher, D. J.; Park, Y. S.; Thayumanavan, S., *Acc. Chem. Res.* **1996**, *29*, 552-560.
13. Hodgson, D. M.; Kloesges, J., *Angew. Chem. Int. Ed.* **2010**, *49*, 2900-2903.
14. (a) Beak, P.; Yamamoto, J.; Upton, C. J., *J. Org. Chem.* **1975**, *40*, 3052-3062; (b) Seebach, D.; Lubosch, W., *Angew. Chem. Int. Ed.* **1976**, *15*, 313-314; (c) Lubosch, W.; Seebach, D., *Helv. Chim. Acta* **1980**, *63*, 102-116; (d) Tominaga, Y.; Kohra, S.; Hosomi, A., *Tetrahedron Lett.* **1987**, *28*, 1529-1531.
15. Behloul, C.; Guijarro, D.; Yus, M., *Synthesis* **2006**, *2006*, 309,314.
16. Chang, D.; Feiten, H.-J. r.; Engesser, K.-H.; van Beilen, J. B.; Witholt, B.; Li, Z., *Org. Lett.* **2002**, *4*, 1859-1862.

Chapter 4

Formation of Reactive C-Acylimines by Trapping of Metallocarbenes with Azides

4.1. Introduction

The reactivity of metallocarbenes (**1**) toward nitrogen is well established in the literature.¹ Their ability to generate reactive ylide intermediates (**I-IV**), from reaction of **1** with tertiary amines, amides, imines or nitriles (Scheme 4.1), as well as the capacity to undergo N-H insertion reaction makes them extremely versatile, allowing access to a wide array of different molecular frameworks.²

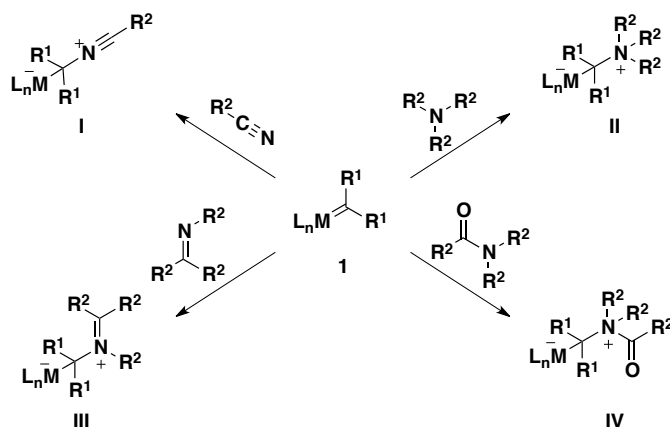

Scheme 4.1: Pathways of metallocarbene reactivity with nitrogen nucleophiles.

The most commonly used method for the generation of metallocarbenes is through the decomposition of diazo compounds with late transition metal catalysts (Cu, Rh, Pd, Fe, Co, Ru).³ These complexes function as Lewis acids that are

coordinatively unsaturated at the metal center and are capable of stabilizing the metal bound carbene. The mechanism of ylide formation from diazo compounds is shown in Scheme 4.2. This process begins with addition of the diazo compound (**3**) to the metal (**2**) followed by loss of nitrogen to give the metalcarbene intermediate (**VI**). Metalcarbene intermediate **VI** is very electrophilic and quickly reacts with a nucleophile (**Nu**), in this case the lone pair on nitrogen, to generate the metal bound ylide **VII**. This ylide can undergo subsequent transformations as is or dissociate from the transition metal to give the free ylide **VIII**.

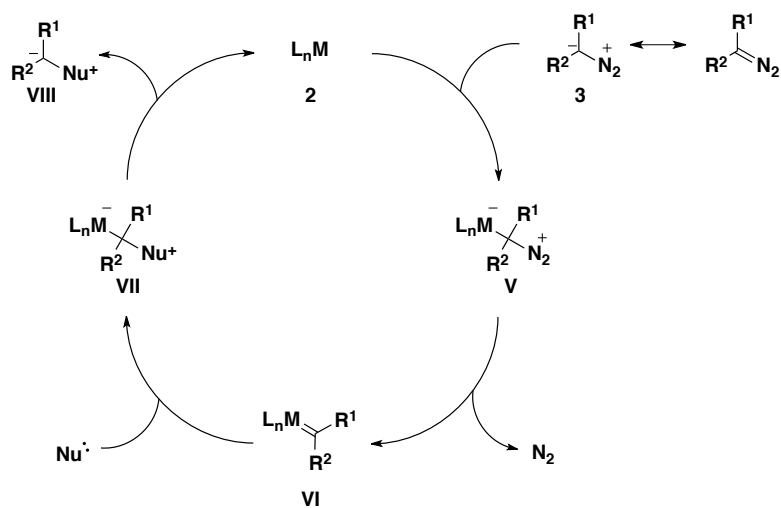

Scheme 4.2: Mechanism of ylide generation *via* metalcarbenes.

Successful reactivity of metalcarbenes and nitrogen-containing compounds is often dependent on which metal catalyst is employed. Commonly employed catalysts are Cu(I) salts, such as CuOTf, Cu(II) salts, such as Cu(acac)₂, Cu(tfacac)₂, and Cu(hfacac)₂, and Rh(II) carboxylates, such as Rh₂(OAc)₄ (Figure 4.1). Some catalysts, like those derived from Rh(II), have a high affinity for basic nitrogen. This means that the amine substrate can potentially act as a ligand and shut down the desired reaction.⁴ Increasing the reaction temperature or screening other metal catalysts can generally solve this problem.

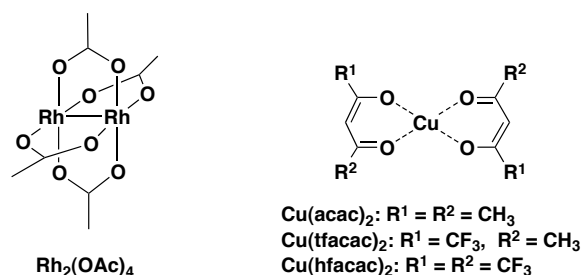
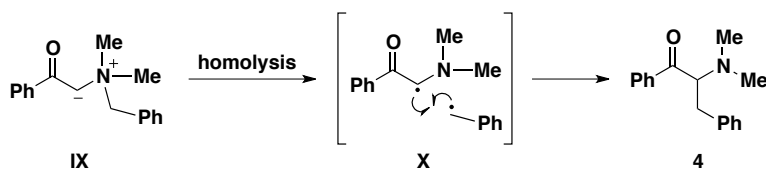

Figure 4.1: Commonly employed catalysts in ammonium ylide formation.

4.1.1. Reaction of Metallo-carbenes with Amines

Ammonium ylides derived from tertiary amines and metallo-carbenes have been extensively studied by several groups, including the West group, as a means to access a wide variety of acyclic and cyclic nitrogen-containing compounds.⁵ There are two reaction pathways commonly observed with ammonium ylides: the Stevens [1,2]-shift pathway and the [2,3]-rearrangement pathway.

The Stevens [1,2]-shift pathway, which is explained in greater detail in chapter 2, involves the formation of an ammonium ylide intermediate (**IX**) followed by homolytic cleavage of a carbon-nitrogen bond to give a radical pair intermediate **X** (Scheme 4.3). This radical pair, which is presumably held in close proximity by a solvent cage, recombines to form the [1,2]-shift product. This process has been successfully demonstrated with a large array of substrates ranging from acyclic amines (eq 1)⁶ and simple heterocycles (eq 2-3),⁷ to more complex natural product frameworks (eq 4-5).⁸



Scheme 4.3: Mechanism of the Stevens Rearrangement.

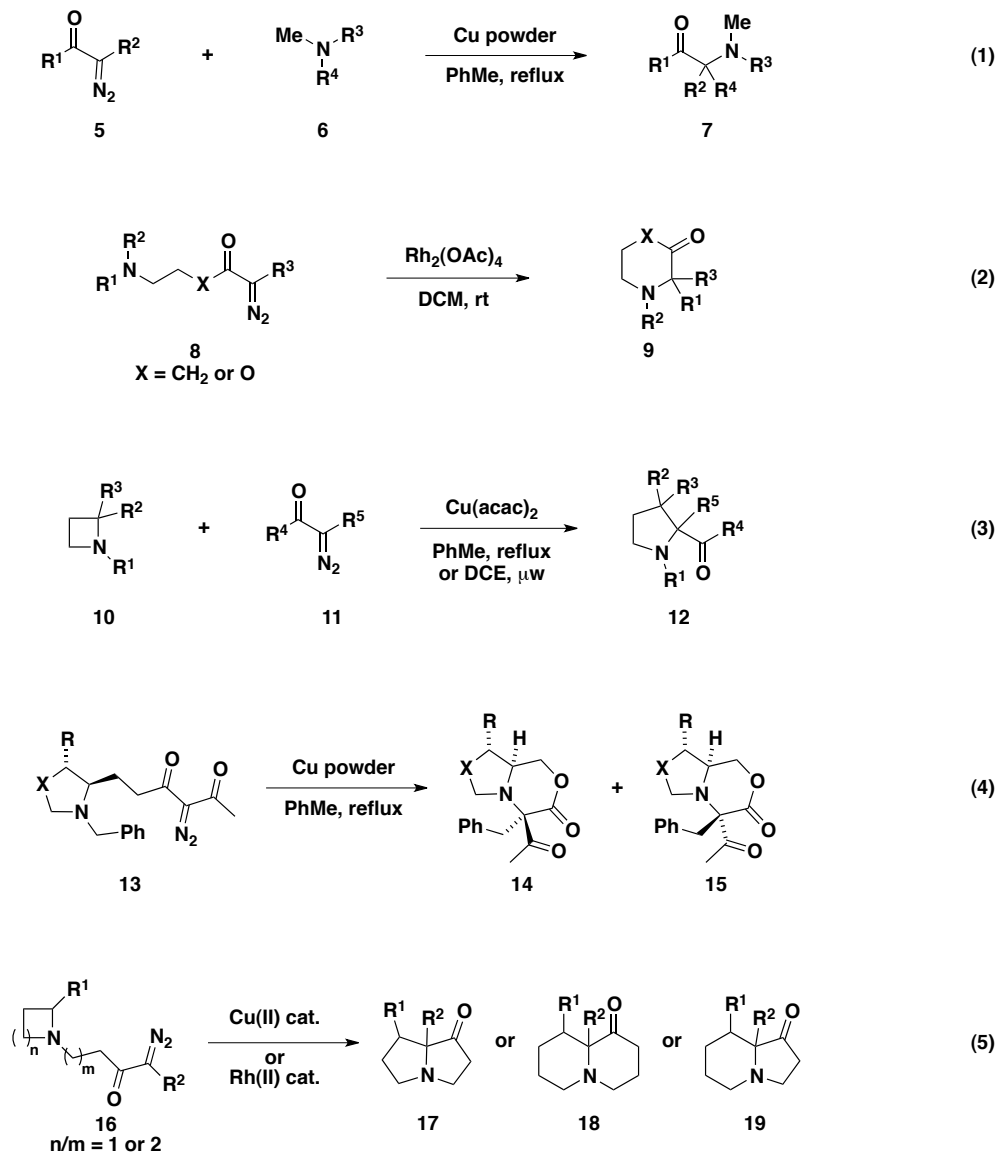

The [2,3]-rearrangement is the pathway often observed when the nitrogen bears an allylic or propargylic substituent. In most cases, the concerted [2,3]-rearrangement pathway will dominate over the [1,2]-shift pathway as long as there is sufficient overlap of the necessary orbitals. This is presumably due to a lower activation barrier for the concerted process. A simple example of a [2,3]-shift, and the mechanism of the rearrangement, is shown with allylamine **20** in equation 6.⁴ More complex examples of this rearrangement have allowed access to mono and bicyclic amines with a wide range of ring sizes (eq 7-10).⁹

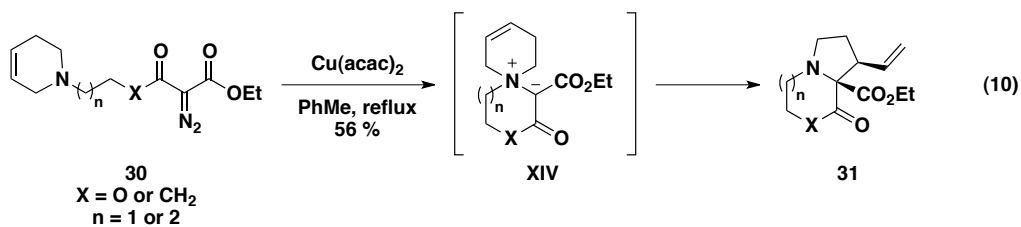
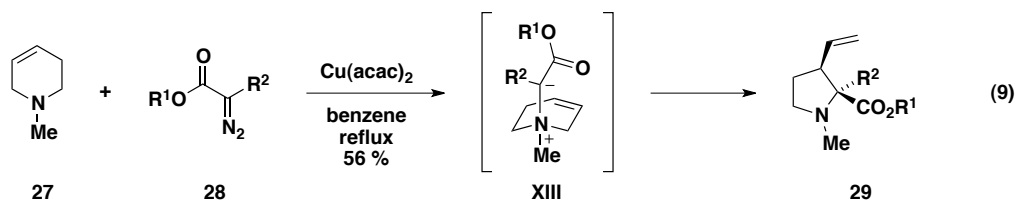
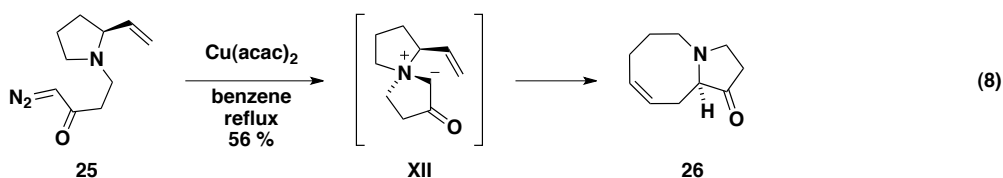
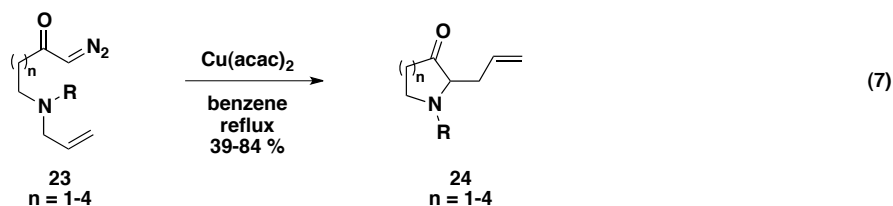
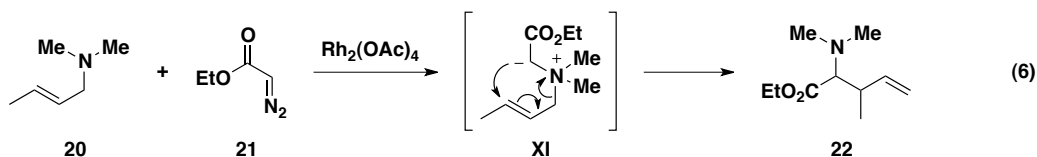

4.1.2. Reaction of Metallocarbenes with Imines

Imines have been shown to react with diazocarbonyl compounds in the presence of copper or rhodium metal catalysts to form azomethine ylides (**XV**).¹⁰ The ylide intermediate can subsequently undergo a [3+2] cycloaddition with another equivalent of imine or, if available, a different molecule possessing a

reactive π -bond (Scheme 4.4).^{11, 10a} This process has been used to assemble highly functionalized heterocyclic systems, such as imidazolines (**34**), oxazoles (**35**) or pyrrolidines (**36**) in one step.

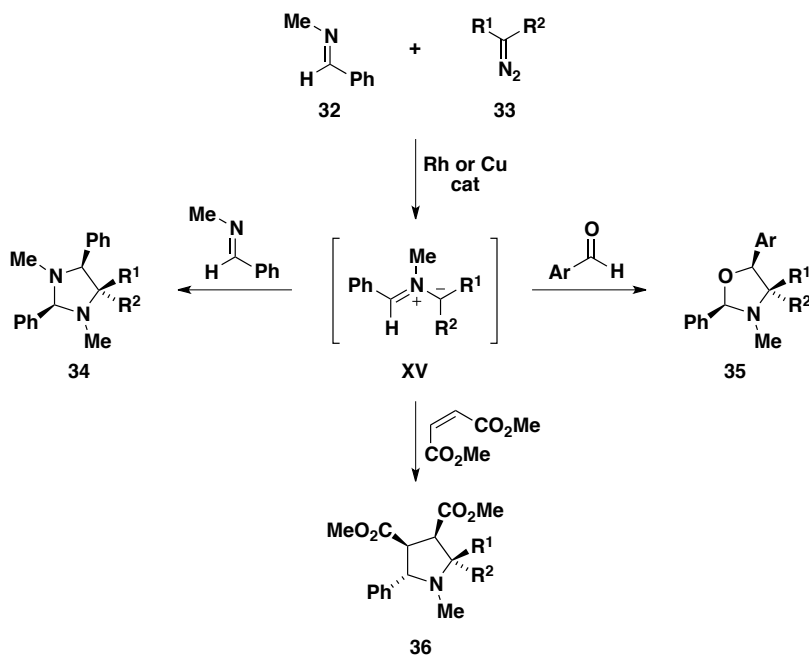

Scheme 4.4: Reactions of metalcarbene derived azomethine ylides.

4.1.3. Reaction of Metalcarbenes with Amides

It has been established that ammonium ylides can be derived from the intramolecular reaction of metalcarbenes with amides; however, this process can be quite dependent on the reaction conditions used.¹² Padwa and coworkers reported that diazo-amides **37** and **38** were converted to **39** and **40** respectively when treated with catalytic $\text{Rh}_2(\text{OAc})_4$ (Scheme 4.5).¹³ In the case of diazo-amide **37**, [1,2]-shift product **39** was obtained in 62 % yield *via* a process that is presumed to involve formation of N-acylammonium ylide **XVI**, followed by bond homolysis to radical pair **XVII** and radical recombination. The ylide derived from diazo-amide **38**, on the other hand, reacted *via* an α' - β -fragmentation pathway generating *N*-ethyl amide **40** in 75 % yield.

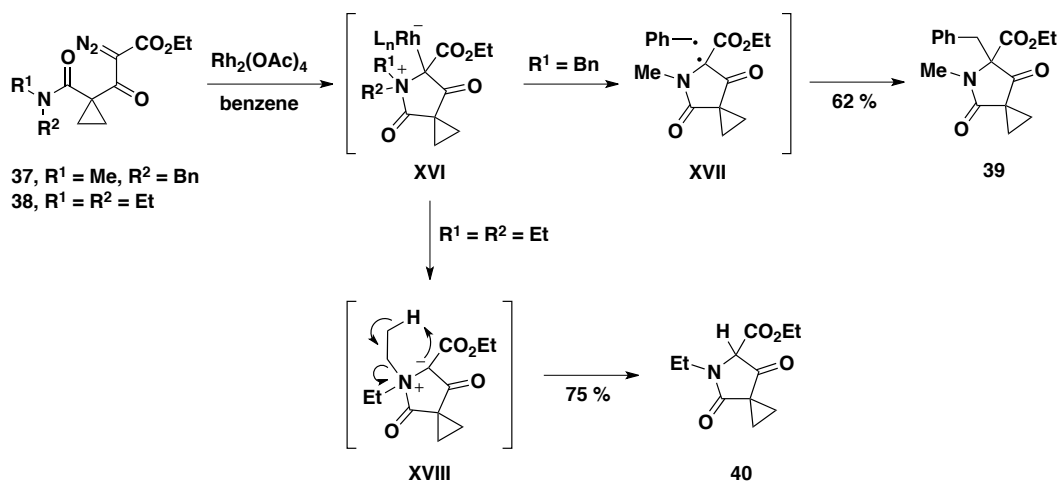

Scheme 4.5: Intramolecular ylide formation with amides.

Although the above examples were successful in generating products derived from ammonium ylides the reactivity of amides with metallocarbene derivatives can also occur via the oxygen of the amide, producing a carbonyl ylide. This was observed when the authors performed the same reaction with the addition of an equivalent of dimethyl acetylenedicarboxylate (DMAD) (Scheme 4.6). The formation of **41** and **42**, which dominated in these cases, was the result of a cycloaddition between the carbonyl ylide intermediate **XIX** and DMAD.

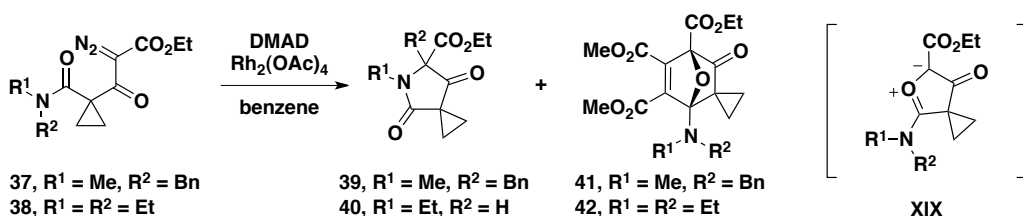

Scheme 4.6: Change in ylide reactivity upon the addition of DMAD.

The change in reactivity in the above example suggests that an equilibrium exists between ammonium and carbonyl ylide intermediates. A similar investigation reported by Kappe the same year looked into ammonium vs. carbonyl ylide formation in diazo-acetal ureas (**43**).¹⁴ In the presence of Rh₂(OAc)₄ the reaction resulted in the formation of an isolable ammonium ylide

(**44**) as a crystalline solid in 68 % yield. This suggested that the formation of the ammonium ylide (**44**) was more thermodynamically favoured than carbonyl ylide intermediate **XXI** (Scheme 4.7).

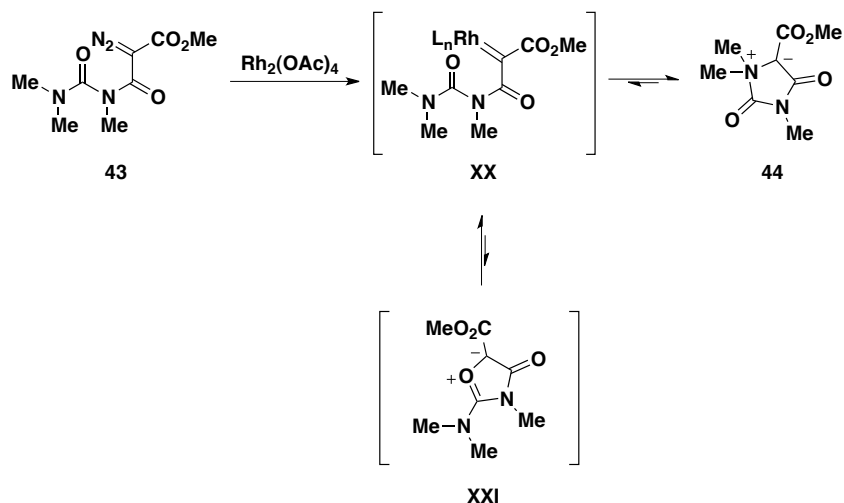

Scheme 4.7: Equilibrium between ammonium and carbonyl ylides.

This hypothesis was strengthened when the authors ran the reaction again in the presence of DMAD (Scheme 4.8). The observed yields of **44**, **45** and **47** again suggest that ammonium ylide **44** is thermodynamically favoured but that carbonyl ylide **XXI**, which must be present in small amounts, is more reactive with DMAD, resulting in **47** via a facile 1,3-dipolar cycloaddition followed by extrusion of methyl isocyanate.

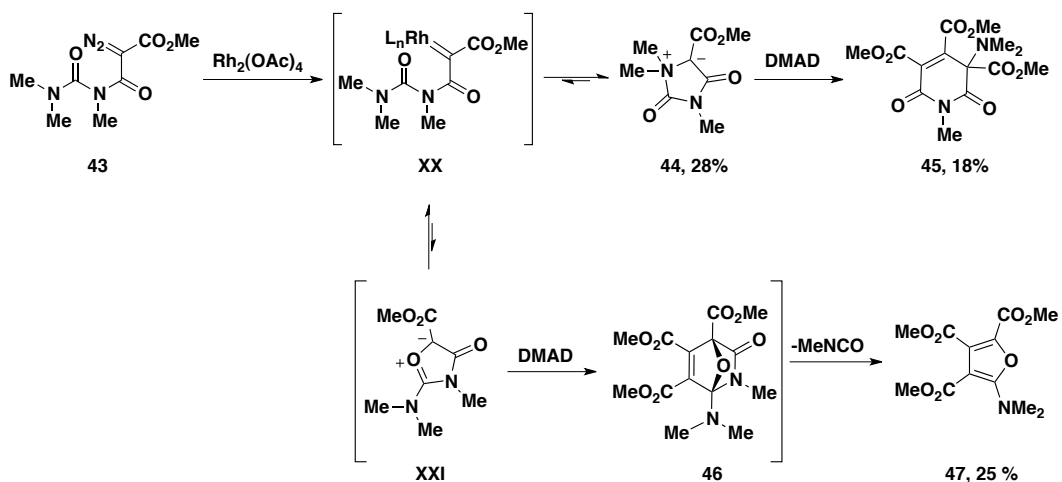

Scheme 4.8: Insight into ylide equilibrium in the presence of DMAD.

4.1.4. Reaction of Metallocarbenes with Nitriles

The formation of a nitrile ylide by reaction with a metallocarbene is useful method for the generation of oxazoles, pyrroles and other complex heterocycles.¹⁵ The intramolecular 5-*endo dig* cyclization of the intermediate ylide **XXII** results in formation of oxazole **50**, whereas in the presence of a dipolarophile such as DMAD the pyrrole derivative **51** can be obtained (Scheme 4.9).

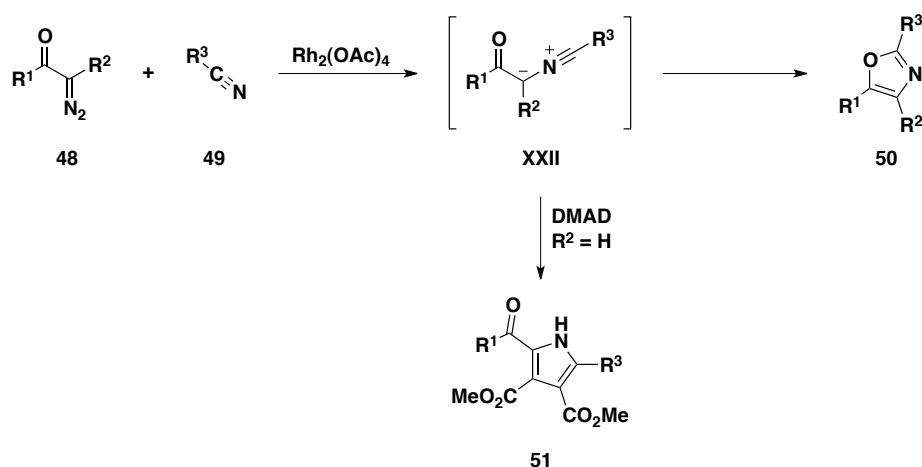

Scheme 4.9: Reactions of nitrile ylides.

4.2. Reaction of Metallocarbenes with Azides

One area of this chemistry that appears to be underexplored is the reaction of metallocarbenes with organic azides. A thorough search of the literature brought up only three reported examples. Interestingly, the first example, reported by Kirmse and Arold in 1968¹⁶ was at the forefront of exploration into the use of metal catalysts to decompose diazo compounds. When the authors subjected allylazide (**52**) to diazomethane in the presence of copper (I) chloride they were able to isolate a small amount cyclopropylazide **53** as well as the hexahydrotriazine **54** (Scheme 4.10). The hexahydrotriazine product was most

likely the result of nucleophilic attack on the metallocarbene by the azide nitrogen followed by loss of nitrogen gas to give imine **55**. A subsequent [2+2+2]-cyclization of three equivalents of **55** would result in the formation of the hexahydrotriazine **54**.

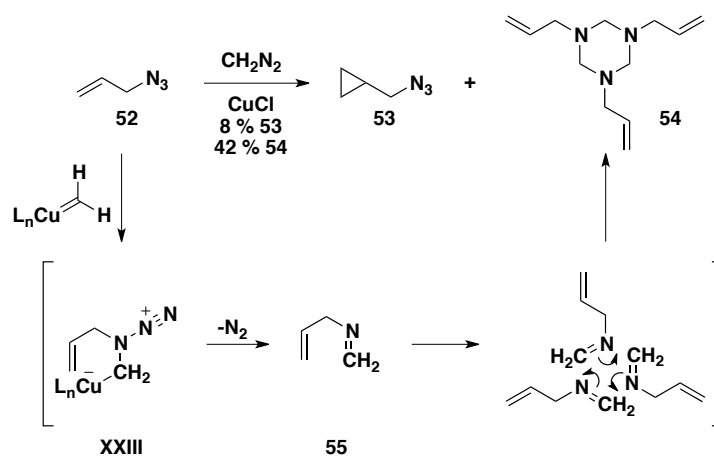

Scheme 4.10: Early example of azides reacting with metallocarbenes.

There have subsequently been two more examples where similar reactivity was observed. In 1996, the Wee group observed the interception of a Rh-derived metallocarbene with the azide nitrogen of diazoamides **56** and **57**, which resulted in the formation of tricyclic C-acylimine derivatives **58** and **59** (Scheme 4.11). A similar result, published just recently by Micoutin and coworkers,¹⁷ allowed the authors to gain access to bicyclic heterocycle **63** in just a few steps from diaminocyclopentanol (**60**, Scheme 4.12).

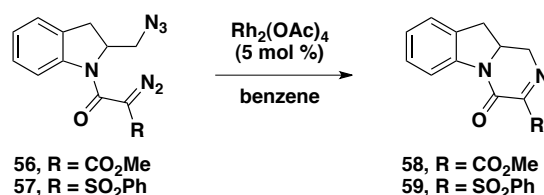

Scheme 4.11: First example of Rh-catalyzed reaction of an azide with a metallocarbenes.

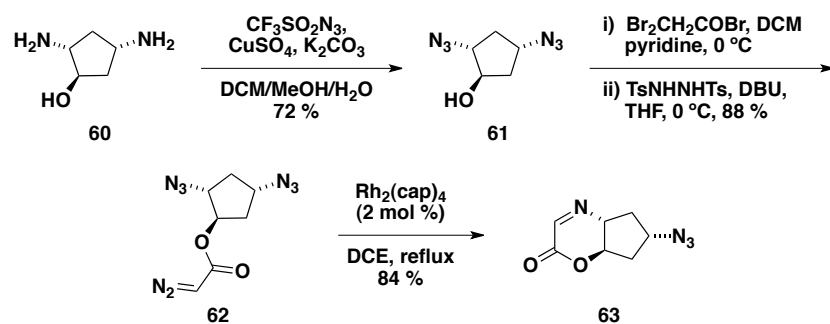

Scheme 4.12: Use of azide/metallocarbene chemistry for derivatization of diaminocyclopentanol.

The potential of this relatively unexplored area of metallocarbene chemistry was very appealing to us and we sought out to use the azide moiety, and its inherent potential to lose N_2 , to generate C-acylimines in an environmentally benign fashion. We believed that tethering the azide and the diazocarbonyl functionalities, such as in compound **64**, would encourage intramolecular reactivity between the internal azide nitrogen and the *in situ* derived metallocarbene **XXIV**. After ring closure, intermediate **XXV** would subsequently eliminate N_2 leaving us with **65** (Scheme 4.13). Our hope was that **65** could then be activated to allow for further functionalization to more complex structures.

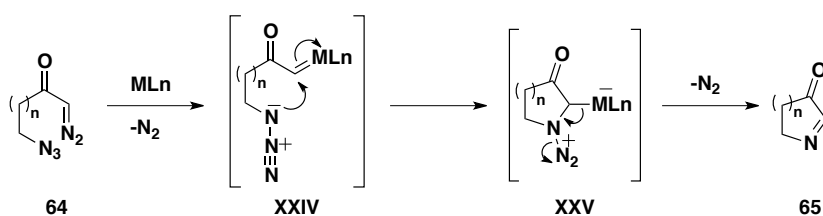

Scheme 4.13: Proposed route to cyclic C-acylimines.

4.3. Results and Discussion

Our initial plan was to synthesize a simple alkyl-tethered diazo-azide compound, such as 4-azido-diazobutanone (**67**), from readily available starting materials (Scheme 4.14). The substrate was prepared in two steps from

commercially available 3-bromopropionic acid (**66**) but unfortunately, was only stable when kept in solution, making purification impractical.

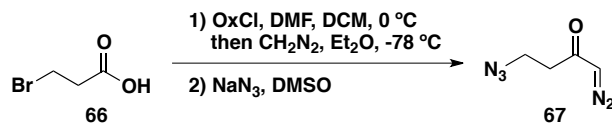

Scheme 4.14: Attempted synthesis of a simple azide-tethered diazocarbonyl compound.

We believed that the substrate stability problem, which was most likely the result of the ratio of nitrogen to carbon in the initial target being too low,¹⁸ could be overcome by increasing the molecular weight of the test substrate. Anthranilic acid (**68**) seemed to be an excellent candidate to accomplish this goal, as it was inexpensive, readily available and most importantly, the functional groups were in an *ortho*-relationship to one another. Conversion of **68** to the diazo-azide derivative **70** was accomplished in two one-pot procedures (Scheme 4.15). The first step, exchanging the amine for the azide, was achieved *via* displacement of the *in situ* generated diazonium species (**XXVI**) with sodium azide using a known procedure.¹⁹ After drying, 2-azidobenzoic acid (**69**) was subsequently transformed into **70** by conversion of the acid moiety to the acid chloride with oxalyl chloride (OxCl), followed by addition of an ethereal solution of diazomethane.

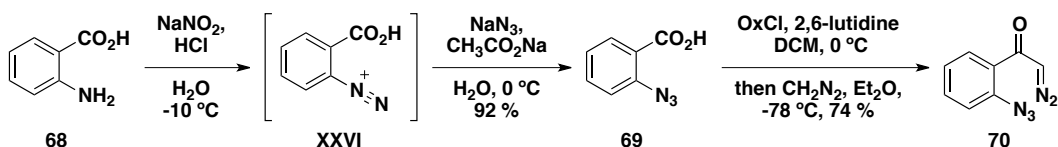

Scheme 4.15: Synthesis of a stable diazo-azide test substrate.

Our initial test reaction with **70**, using $\text{Cu}(\text{acac})_2$ as the diazo-decomposition catalyst and toluene as the solvent, showed a fast consumption of starting material at room temperature and led to the isolation of a small quantity of indolone **71** as a bright red solid (Scheme 4.16). This product was the result of

trapping of the target intermediate C-acylimine species (**XXVII**) with an anionic acetylacetonate ligand from the catalyst, followed by subsequent autoxidation to give the exocyclic double bond. With this interesting result in hand we decided to see if adding an external nucleophilic trap to the reaction flask would allow for construction of other substituted indolone derivatives.

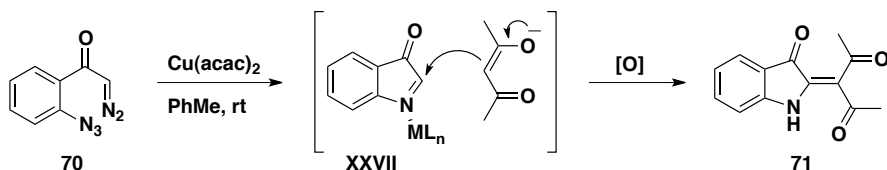

Scheme 4.16: Initial test reaction with diazo-azide **70**.

Addition of silyl ketene acetal (**72**) to the reaction mixture resulted in isolation of both indolone (**71**), seen previously, as well as a new indolone derivative (**73**, Scheme 4.17). The *Z*-stereochemistry of **73** was confirmed by comparison of the NMR data we obtained with the reported NMR data for the known *cis*-isomer of **73**, which the authors had confirmed by X-ray spectroscopic analysis.²⁰

The formation of indolone **73** with the addition of silyl ketene acetal **72** to the reaction mixture was quite promising and we consequently set out to optimize the reaction for preferential formation of this product over that observed from trapping with the ligands of the metal catalyst. A screen of several catalysts revealed that Cu(tfacac)₂, Cu(hfacac)₂ and Rh₂(OAc)₄ were all capable of catalyzing the reaction. Cu(hfacac)₂ was chosen as the preferred catalysts for additional investigations because it catalyzed the reaction most efficiently at room temperature without the formation of side-products resulting from trapping of the C-acylimine intermediate with the hexafluoroacetylacetonate (hfacac) ligand. The lack of the observed ligand-trapped product is presumably due to the lower nucleophilicity of the hfacac methylene. Upon further optimization it was found that indolone **73** could be reproducibly isolated in excellent yield when the diazo-

azide substrate was added to two equivalents of silyl ketene acetal **72** and 10 mol % of $\text{Cu}(\text{hfacac})_2$ over 1h *via* syringe pump.

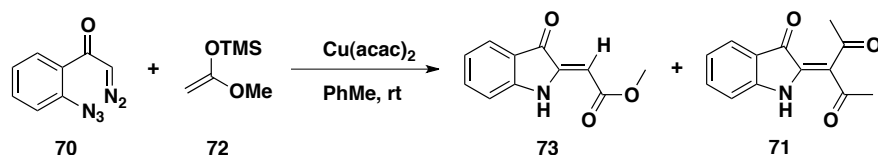

Scheme 4.17: Indolone derivatives by *in situ* trapping of the C-acylimine with a silyl ketene acetal.

We then turned our investigation toward looking for other nucleophiles that could react with the C-acylimine intermediate without interfering with the initial metallocarbene formation step (Table 4.1). It is well known that both oxygen and nitrogen can readily bind with some copper catalysts, rendering them inactive, therefore our initial screening looked at carbon nucleophiles. It was found that *in situ* indolone formation was facile with the more highly substituted silyl ketene acetal (**74**), Danishefsky's diene (**76**) and sodium acetoacetate (**78**) (entries 2-4). Acetylacetone (**79**) was also capable of trapping the C-acylimine intermediate (entry 5), but the time scale of the reaction was a great deal slower. Attempts at trapping with dimethylbutadiene (entry 6), *in situ* reduction with triethylsilane (entry 7) or alkylation with phenylboronic acid pinacol ester **81** (entry 8) were unsuccessful.

The formation of **77** was the result of an aza-Diels-Alder reaction of the C-acylimine intermediate **XXVII** with Danishefsky's diene (**76**), followed by hydrolysis of **82** to give enone **83**. Enone **83** underwent subsequent autoxidation to generate the observed 4-pyridone product **77** (Scheme 4.18). Isolation and purification of **77** was initially found to be difficult because the product was soluble in both aqueous and organic solvents. This was most likely due to contributions from the zwitterionic resonance form **77'**. The contribution of the zwitterionic form was supported by the IR spectrum. Initial attempts to obtain an IR spectrum by the cast film method using DCM as the solvent resulted in

observation of an OH peak at 3393 cm^{-1} . An IR spectrum obtained of the same compound in the solid state, however, did not show an OH stretching band.

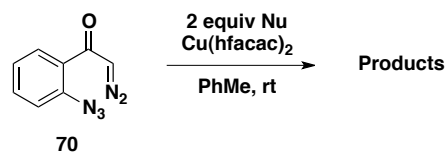

Entry	Nucleophile	Product	Yield (%)
1			96
2			93
3			75
4			78
5			n.d
6		complex mixture	-
7	Et_3SiH	Complex mixture	-
8		Complex mixture	-

Table 4.1: Nucleophilic trapping of reactive C-acylimines with various C-nucleophiles.

Regrettably, an analogous cycloaddition was not observed when dimethylbutadiene was used as a trap. During the reaction the formation of a single new spot was observed by TLC analysis, however, within a few minutes the spot quickly changed colour several times. This suggested the initially formed compound was not stable and all attempts to isolate products from this reaction were met with failure.

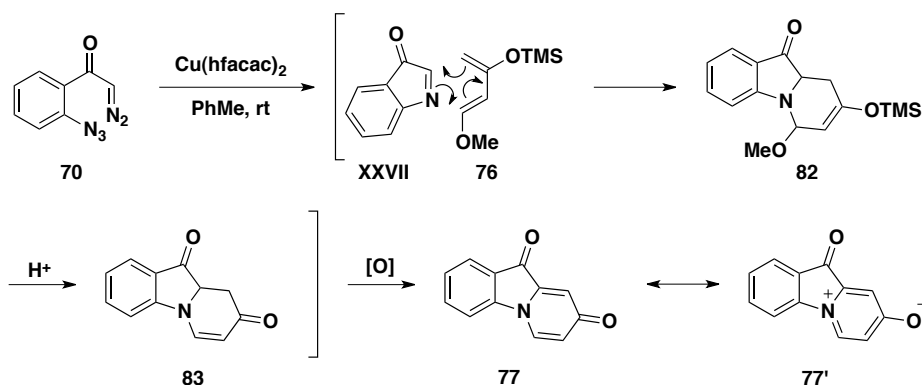

Scheme 4.18: Mechanism for the formation of the tricyclic indolone derivative 77.

Interestingly, in the case of trapping with β,β -disubstituted silyl ketene acetal 74, autoxidation of the initially formed indolone product (75) occurred at a much slower rate than that observed with indolone 73 derived from silyl ketene acetal 72. This allowed for isolation of 75 in excellent yield if purification was completed quickly. With prolonged exposure to air, however, 75 was oxidized to α -hydroxy derivative 84 (Scheme 4.19). Furthermore, exposure of 84 to trace acid, like that found in deuterated chloroform, initiated an elimination/oxidation sequence resulting in the formation of nitrene 85.

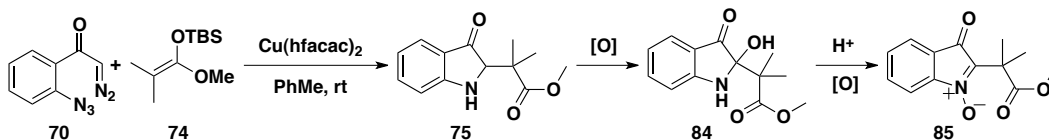

Scheme 4.19: Stepwise oxidation of indolone derivative 75.

With the success observed with diazo-azide substrate **70**, we then decided to investigate whether or not similar results could be obtained with a second stabilizing group on the diazoketone. If a similar reaction were successful, it would allow access to a quaternary center on the resulting indolone in a one-step procedure. The distabilized diazo-azide substrate (**87**) was also readily prepared from anthranilic acid (**68**, Scheme 4.20). Direct conversion of **68** to 1,3-diketone **86** was accomplished in good yield using a titanium-mediated crossed-Claisen procedure reported by Tanabe and coworkers.²¹ Conversion of **86** to the desired distabilized diazo-azide substrate **87** occurred quantitatively using standard Regitz diazotransfer conditions.

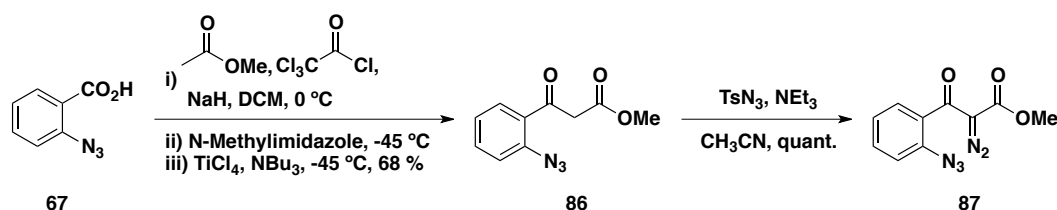

Scheme 4.20: Synthesis of distabilized aryl-tethered diazo-azide substrate.

Diazo-azide **87** was initially reacted with silyl ketene acetal **72** using the standard conditions applied to the mono-stabilized substrate (see Table 4.1). In this case, however, the conditions were found to be too mild to initiate product formation. Heating the reaction to reflux solved this problem and allowed isolation of the indolone **88**, possessing a quaternary center, in good yield (Scheme 4.21). We were also pleased to see that reaction of **87** with the more sterically demanding silyl ketene acetal **74** was also successful in generating an indolone derivative (**89**), albeit in a lower yield. Although the yield of the **89** was lower than observed with the other cases, it is significant in that the product has two adjacent quaternary centers.

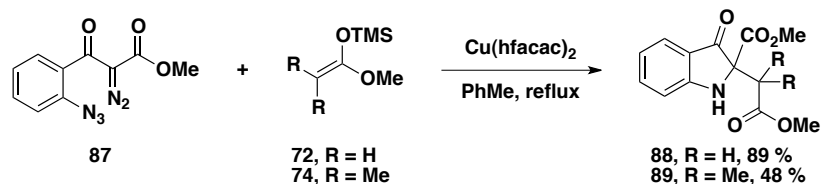

Scheme 4.21: Synthesis of indolones possessing quaternary centers.

To illustrate that this process could be viable in non-aromatic tethered systems we decided to synthesize an acyclic diazo-azide substrate that would be similar to that proposed originally, yet would have enough molecular weight to circumvent the instability issues observed with the original target. Our first acyclic target was diazo-azide **90**, which we believed could be synthesized in a few simple steps from dimethyl malonate (**92**) using procedures for similar compounds found in the literature (Scheme 4.22).

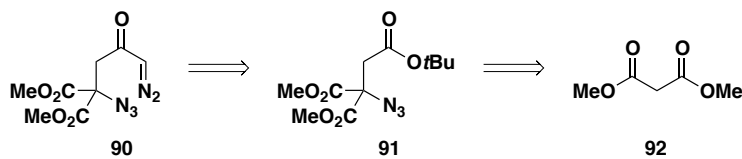

Scheme 4.22: Retrosynthetic approach to an alkyl-tethered diazo-azide substrate.

Alkylation of **92** with *tert*-butyl bromoacetate **93** resulted in a mixture of mono- and di-alkylated products **94** and **95**, as well as leftover starting material. Bulb to bulb distillation allowed for separation of the desired mono-alkylated compound **94** from the di-alkylated compound **95**; however, a small amount of dimethyl malonate was still present. The mixture of **92** and **94** (15:85) was subsequently treated with *N*-bromosuccinamide (NBS) and catalytic benzoyl peroxide (**96**) which, after purification, furnished the desired brominated product in 62 % yield over two steps.²² Displacement of the bromide with azide was attempted using a procedure described by Benati and coworkers;²³ however, these conditions resulted in the formation of α -amino-diazocarbonyl compound **98**. Although interesting, this result led to a re-evaluation of the target compound.

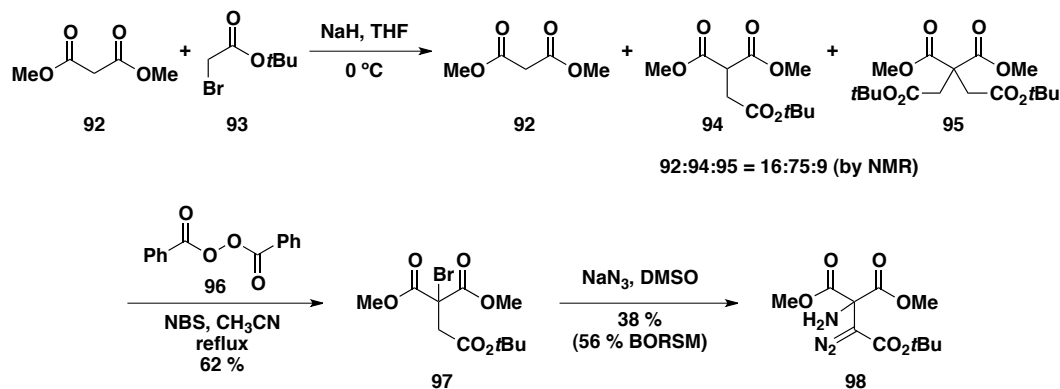

Scheme 4.23: Synthesis of an unexpected α -amino diazocarbonyl compound.

To simplify the structure of the target molecule and eliminate the potential for unwanted side reactions we decided to synthesize diazo-azide **99**. We believed that exchanging the ester groups found in **90** (see Scheme 4.22) with methyl groups would reduce the risk of undesired side reactions caused by the high acidity of the neighbouring protons in **97**. Also, the use of the distabilized diazoketone moiety would allow an increase of molecular weight and reduce the danger associated with a low carbon to nitrogen ratio. Once again, the target compound was envisioned to come from inexpensive, commercially available building blocks (Scheme 4.24).

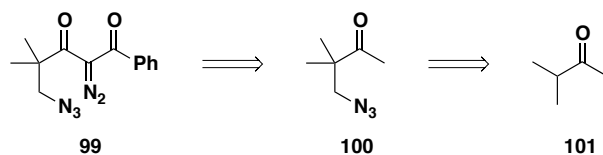

Scheme 4.24: Retrosynthetic analysis of an acyclic, distabilized diazo-azide substrate.

A mixture of 3-methyl-2-butanone (**101**) and paraformaldehyde were refluxed in trifluoroacetic acid (TFA) according to the procedure reported by De Kimpe and coworkers to provide 3,3-dimethyl-4-hydroxy-butanone (**102**) in excellent yield (Scheme 4.25).²⁴ Subsequent conversion of **102** to the mesylate, followed by displacement with sodium azide using microwave irradiation conditions gave 3,3-dimethyl-4-azido-butanone (**100**) in good yield. Generation

of the lithium enolate of **100**, followed by addition of benzoyl cyanide resulted in isolation of enol **103** after acid hydrolysis. Conversion of enol **103** to the desired diazo-azide target (**99**) was accomplished using standard Regitz diazo-transfer conditions.

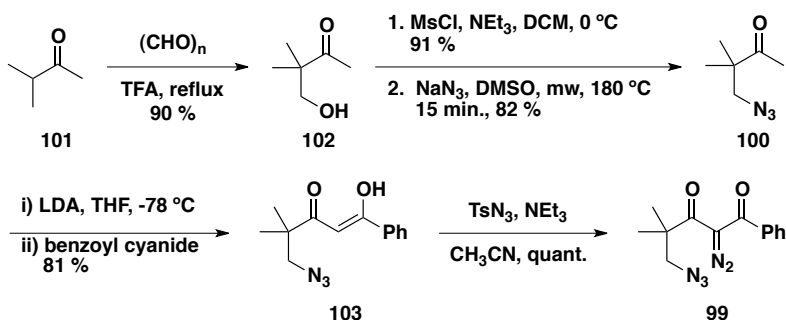

Scheme 4.25: Synthesis of an acyclic diazo-azide substrate.

The mesylate displacement with sodium azide deserves specific comment as optimization of this reaction required a bit of experimentation. The displacement of a mesylate with sodium azide can typically be accomplished by heating the reagents in DMSO anywhere from room temperature to ~ 150 °C. Attempts to produce the desired azide (**100**) using this approach were unsuccessful. Traces of the desired product were obtained at 150 °C; however, the prolonged heating required to consume the starting material (> 48 h) resulted in significant decomposition. We hoped that by switching to microwave heating that we could increase the rate of the reaction and prevent the loss of material due to decomposition. After screening through various microwave conditions (Table 4.2) it was found that irradiation of the reaction mixture at 180 °C for 15 minutes resulted in the formation of **100** in 82% yield which, after workup, could be used without further purification in the next step.

With a successful synthesis of diazo-azide **99** in hand it was time to investigate how it would react when treated with silyl ketene acetal **72** and $\text{Cu}(\text{hfacac})_2$ in refluxing toluene. The results were quite intriguing. Instead of isolating 3-pyrrolidone **106**, as anticipated, we ended up obtaining C-acylimine (**105**) in 71% yield, which could be increased to 95% if a solution of **99** and $\text{Cu}(\text{hfacac})_2$ were heated in the absence of an external nucleophile (Scheme 4.26).

This was quite a fascinating result, as it seemed that the C-acylimine generated with the alkyl-tethered diazo-azide was not reactive toward subsequent nucleophilic trapping.

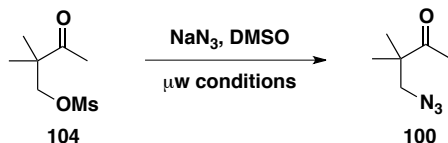

Entry	NaN ₃ (equiv)	Temperature (° C)	Time (min)	Yield (%)
1	1.5	200	60	56
2	1.5	200	30	68
3	1.5	200	15	72
4	1.5	180	15	82
5	1.5	180	10	75
6	1.2	180	15	80
7	1.5	150	15	69*

*starting material was not completely consumed.

Table 4.2: Optimization of the microwave conditions for azide displacement.

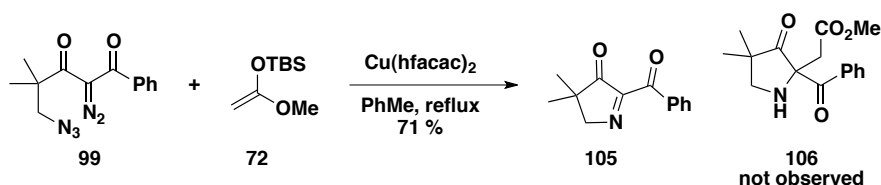

Scheme 4.26: Formation of a stable C-acylimine product.

Attempts to initiate the trapping with subsequent addition of azaphilic Lewis acids such as BF₃•OEt₂ or Cu(OTf)₂ to the reaction flask did not result in the formation of **106**. Further attempts to react the purified C-acylimine with silyl ketene acetal **72** were also unsuccessful. Treating the isolated C-acylimine (**105**) with either ethyl Grignard or diethyl zinc, however, resulted in addition of the ethyl group to the nitrogen (Scheme 4.27), suggesting that the electronics of this substrate are quite different from those of the aromatic cases seen initially.

Unfortunately, the resulting *N*-alkylated product was difficult to isolate in pure form as it underwent facile oxidation to the known 2,3-dicarbonyl compound (**108**), presumably *via* a debenzoylative oxidation sequence similar to others reported in the literature.^{25, 7c}

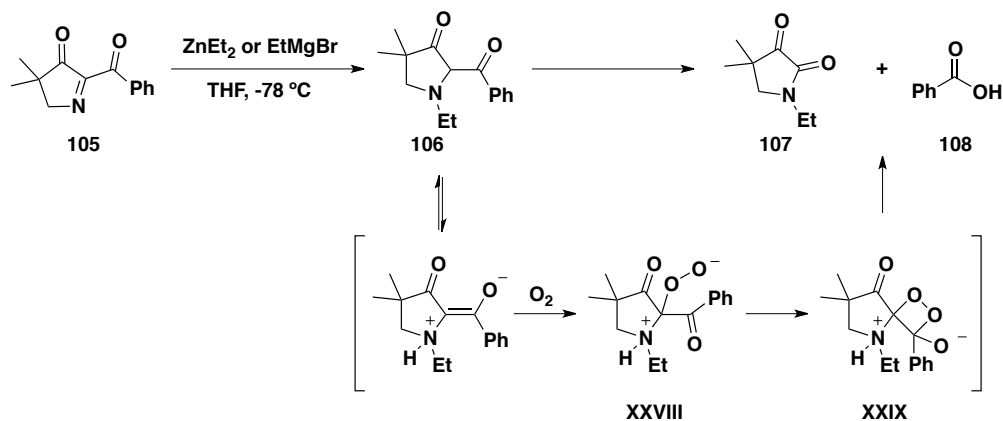

Scheme 4.27: Addition of organometallic reagents to C-acylimine **106**.

Similar *N*-alkylation processes have been observed with the addition of organometallic reagents to acyclic α -iminoesters (Scheme 4.28).²⁶ It has been proposed that bidentate coordination of the metal with both the imine nitrogen and the oxygen of the ester results in a conformationally rigid intermediate (**XXX**) that hinders access to the C-terminus of the imine, however, in many cases the reactions result in C-alkylated or 1,2-carbonyl addition products as well.

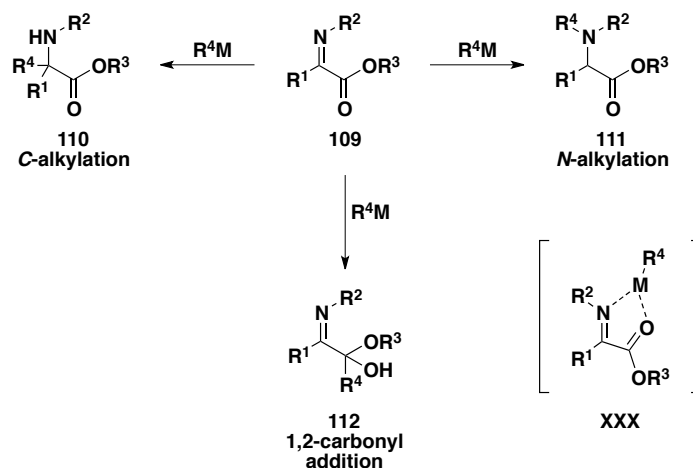

Scheme 4.28: Reactivity of α -aminoesters with organometallic reagents.

4.4. Conclusions

This project has successfully shown that alkyl azides will react with metallocarbenes to generate C-acylimine derivatives. In the case of aryl-tethered diazo-azides the resulting C-acylimines were found to be quite reactive, which allowed for *in situ* trapping with a variety of carbon nucleophiles to give indolone derivatives in excellent yield. Notably, the addition of a second stabilizing group adjacent to the diazo moiety gave rise to products containing quaternary centers. The outcome observed with the alkyl-tethered diazo-azide derivative, on the other hand, was quite different. In this case the C-acylimine was quite stable, showing no reactivity toward the previously successful external nucleophiles under the standard reaction conditions. Instead, this C-acylimine displayed some fascinating umpolung reactivity toward organometallic reagents resulting in *N*-alkylated products.

4.5. Future Directions

The fascinating reactivity we have observed during the early stages of this project suggests there is a great deal of potential in generating reactive C-acylimine intermediates using this approach. Future work will look into homologating the tether between the diazo and azide moieties to determine the limits of ring formation as well as explore the compatibility of other functional groups with the reaction conditions. Ideally, this methodology will be successful for the generation of medium-sized ring systems such as **116** and **117**.

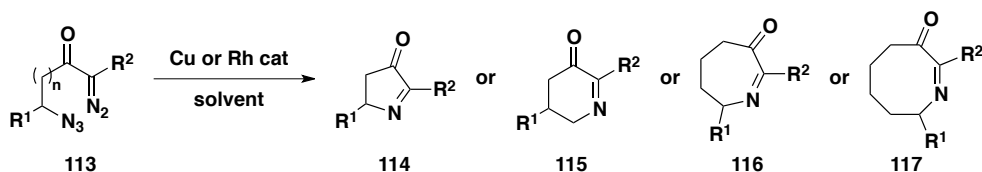

Scheme 4.29: Potential for homologation of the alky-tethered diazo-azide substrates.

Concurrently, it would be essential to explore the nature of the umpolung reactivity of the alkyl-tethered substrates (Scheme 4.30). As the addition of organometallic reagents has not been fully explored at this point it would be beneficial to screen other reagents, such as cuprates or alkyllithiums, to get a greater understanding of this process. The possibility of adding external electrophiles after addition of the organometallic reagent would also be a nice extension of this chemistry, allowing for the formation of highly functionalized compounds in a potential one-pot sequence.

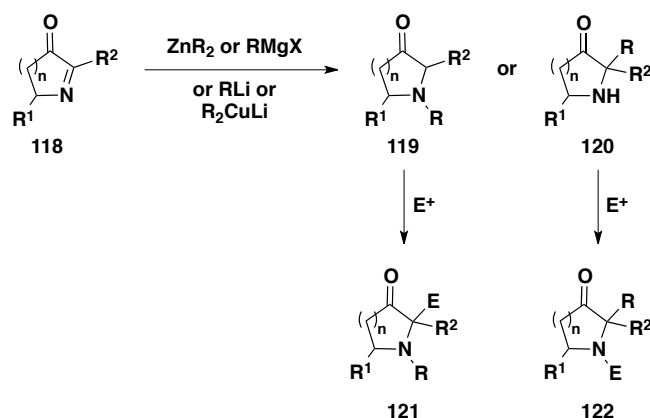

Scheme 4.30: Exploration into the umpolung reactivity of alkyl-tethered diazo-azides.

An intermolecular extension of this methodology would be very useful for synthesizing a wide range of C-acylimines in a quick and easy manner. An early, unoptimized test reaction between **123** and **124** has demonstrated to us that this process is viable for the synthesis of known compound **125** in good yield (Scheme 4.31).

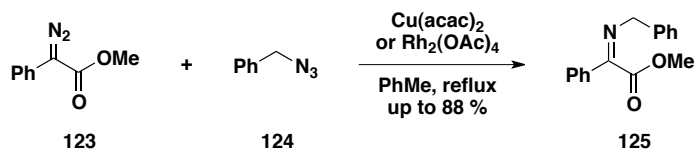

Scheme 4.31: Intermolecular reaction of azides with diazocarbonyl compounds.

The success observed with the trapping of *in situ* formed aryl-tethered C-acylimines with carbon nucleophiles suggests there is a good possibility of expanding this reaction for use in natural products synthesis. Hinckdentine A,²⁷ (+)-isatine A²⁸ and (+)-duocarmycin A²⁹ are biologically active molecules that possess a core that could be envisioned to come from the indolone derivatives accessible by this methodology.

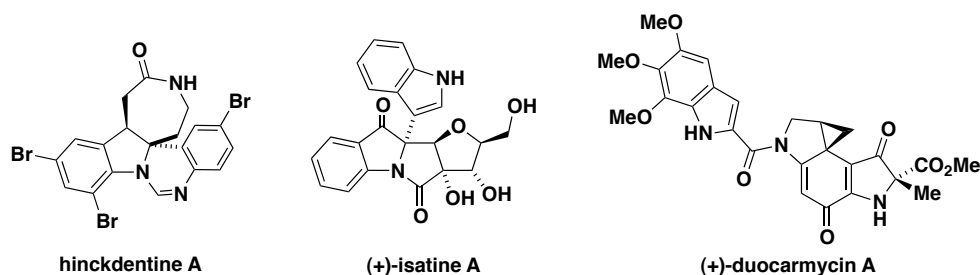

Figure 4.2: Natural products containing an indolone framework.

4.6. Experimental

4.6.1. General Information

Reactions were carried out in oven (130 °C) or flame-dried glassware under a positive argon atmosphere unless otherwise stated. Transfer of anhydrous reagents was accomplished with oven-dried syringes or cannulae. Solvents were distilled before use: acetonitrile (CH₃CN), dichloromethane (DCM) dichloroethane (DCE), and toluene (PhMe) from calcium hydride, diethyl ether (Et₂O) and tetrahydrofuran (THF) from sodium metal. Microwave heating was carried out in a Biotage Initiator microwave reactor, using 2-5 mL microwave vials. Reaction temperature was determined through measurement of the vial surface temperature using an infrared sensor, then correction of internal temperature by the unit's processor using a proprietary algorithm. Thin layer chromatography was performed on glass plates pre-coated with 0.25 mm silica gel with fluorescent indicator UV₂₅₄ (Rose Scientific). Flash chromatography columns were packed with 230-400 mesh silica gel (Silacycle).

4.6.2. Characterization

1-(2-azidophenyl)-2-diazoethanone **70**:

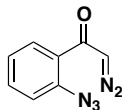

DCM (35 mL) was added to a reaction flask containing 2-azido benzoic acid¹⁹ (1.35g, 8.3 mmol) and the suspension was cooled to 0 °C. Addition of 2,6-lutidine (1.4 mL, 16 mmol) resulted in a homogeneous reaction mixture that was subsequently treated with oxalyl chloride (1.9 mL, 16.4 mmol). The reaction was allowed to stir at 0 °C, with gradual warming to room temperature overnight. Removal of the solvent provided a deep red solid that was immediately dissolved in Et₂O and cooled to -78 °C. Once cooled, the acid chloride solution was transferred via cannula into an ethereal solution of diazomethane (~5 equivalents, prepared from Diazald®) at -78 °C. The reaction was allowed to warm from -78 °C to room temperature overnight. Excess diazomethane was quenched by dropwise addition of glacial acetic acid. The solution was subsequently washed with an equal volume of water (2x), 1M NaOH (3x) and brine. The combined organic layers were then dried over MgSO₄, filtered and concentrated to provide a yellow oil. Purification by flash chromatography, using a 9:1 mixture of hexanes:EtOAc, gave **70** in 74 % yield. To prevent decomposition the product was stored under Ar in the freezer in a foil wrapped flask. Under these conditions the compound was stable over several months.

70: bright yellow crystalline solid; (m.p. = 66-67 °C), $R_f = 0.5$ (4:1 hexanes:EtOAc); IR (cast film) 3138, 2199, 2119, 1603, 1590, 1567, 1479, 1445, 1347, 1313, 1286 cm⁻¹; ¹H NMR (300 MHz, CDCl₃) $\delta = 7.79$ (br d, $J = 6.3$ Hz, 1H); 7.50 (ddd, $J = 1.4, 7.0, 7.0$ Hz, 1H), 7.26-7.19 (m, 2H), 6.18 (br s, 1H); ¹³C NMR (125 MHz, CDCl₃) $\delta = 184.9, 137.9, 132.8, 130.2, 129.3, 125.0, 118.9, 58.0$; HRMS calc'd for C₈H₅N₅ONa [M + Na]⁺ 210.0386, found 210.0385.

General Procedure for the reaction of diazo-azide substrate **70** with external nucleophiles.

A solution of diazo-azide **70** in toluene (0.04 M) was added via syringe pump over 1h to a solution of the nucleophile (2 equiv, 0.04 M in toluene) and Cu(hfacac)₂ (10 mol %) at room temperature. The reaction mixture turned dark brown over the course of the addition. Once the addition was complete, the reaction was monitored by TLC for consumption of the diazo-azide starting material. The reaction was typically complete within 15 minutes of the conclusion of the syringe pump addition. In most cases, the reaction mixture was washed with an equivalent volume of 0.5 M aqueous solution of K₂CO₃ and brine. The combined organic layers were then dried over MgSO₄, filtered, concentrated under reduced pressure and purified by flash chromatography. The one exception, for the formation of **77** using Danishefsky's diene (**76**) as the nucleophile, gave better results by evaporating the crude reaction mixture followed by direct column chromatography.

3-(3-oxoindolin-2-ylidene)pentane-2,4-dione **71**:

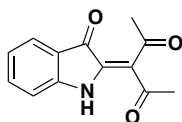

Isolated as bright red needles in 78% yield; m.p. = 219-221 °C R_f = 0.36 (4:1 hexanes:EtOAc); IR (KBr pellet) 3302, 2924, 1715, 1683, 1638, 1615, 1573, 1465 cm⁻¹; ¹H NMR (500 MHz, CDCl₃) δ = 10.21 (br s, 1H, NH), 7.67-7.66 (m, 1H), 7.53 (ddd, J = 1.4, 7.4, 8.0 Hz, 1H), 7.04 (dt, J = 0.8, 7.4 Hz, 1H), 6.98-6.96 (m, 1H), 2.59 (s, 3H), 2.29 (s, 3H); ¹³C NMR (125 MHz, CDCl₃) δ = 203.4, 197.6, 188.6, 152.9, 140.2, 137.7, 125.6, 122.6, 119.4, 116.8, 112.2, 32.3, 28.9; HRMS calc'd for C₁₃H₁₁NO₃ [M⁺] 229.0739, found 229.0714.

Z-methyl 2-(3-oxindolin-2-ylidene)acetate 73:²⁰

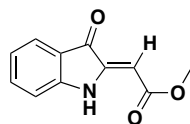

Isolated as orange/red needles in 96% yield; m.p. = 183-185 °C; R_f = 0.51 (7:3 hexanes:EtOAc); IR (cast film) 3362, 3057, 2997, 1720, 1662, 1606, 1468, 1309, 1209 cm^{-1} ; ^1H NMR (500 MHz, CDCl_3) δ = 8.85 (br s, 1H), 7.69 (br d, J = 7.4 Hz, 1H), 7.51 (app dt, J = 1.3, 7.7 Hz, 1H), 7.00 (app dt, J = 0.5, 7.5 Hz, 1H), 6.94 (d, J = 8.0 Hz, 1H), 5.89 (s, 1H), 3.84 (s, 3H); ^{13}C NMR (125 MHz, CDCl_3) δ = 186.8, 169.2, 152.8, 145.2, 137.4, 125.5, 121.6, 120.3, 111.6, 92.6, 51.8; HRMS calc'd for $\text{C}_{11}\text{H}_9\text{NO}_3$ [M^+] 203.0582, found 203.0609. Anal. calc'd for $\text{C}_{13}\text{H}_{11}\text{NO}_3$: C: 65.02, H: 4.46, N: 6.89, found C: 65.04, H: 4.63 N: 6.62.

Methyl 2-methyl-(3-oxindolin-2-yl)propanoate 75:

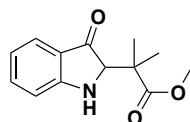

Isolated as a yellow oil in 93 % yield; R_f = 0.24 (4:1 hexanes:EtOAc); IR (cast film) 3364, 2980, 2951, 1726, 1692, 1620, 1489, 1471 cm^{-1} ; ^1H NMR (500 MHz, CDCl_3) δ = 7.59 (d, J = 7.2 Hz, 1H), 7.47-7.43 (m, 1H), 6.89 (d, J = 8.3 Hz, 1H), 6.85-6.82 (m, 1H), 4.95 (br s, 1H), 4.04 (d, J = 3.0 Hz, 1H), 3.77 (s, 3H), 1.46 (s, 3H), 1.20 (s, 3H); ^{13}C NMR (125 MHz, CDCl_3) δ = 200.4, 176.9, 161.1, 137.0, 124.3, 122.6, 119.1, 112.5, 67.7, 52.3, 46.3, 20.9, 19.6; HRMS calc'd for $\text{C}_{13}\text{H}_{15}\text{NO}_3$ [M^+] 233.1052, found 233.1045.

Compound 77:

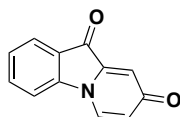

Isolated as a bright orange powder in 75% yield; m.p: 213-214 °C (decomposition); $R_f = 0.18$, 9:1 EtOAc:MeOH; IR (KBr pellet) 3116, 3064, 1710, 1669, 1644, 1607, 1595, 1554, 1493, 1470, 1329, 1310 cm^{-1} ; ^1H NMR (500 MHz, CDCl_3) $\delta = 7.89$ (app br d, $J = 7.5$ Hz, 2H), 7.75 (app dt, $J = 1.3, 8.2$ Hz, 1H), 7.40 (d, $J = 8.2$ Hz, 1H), 7.37 (dt, $J = 0.6, 7.6$ Hz, 1H), 7.00 (d, $J = 2.0$ Hz, 1H), 6.61 (dd, $J = 2.0, 8.0$ Hz, 1H); ^{13}C NMR (125 MHz, CDCl_3) $\delta = 183.9, 180.6, 147.1, 139.4, 137.2, 130.5, 126.4, 126.2, 123.2, 118.9, 116.3, 110.4$. HRMS calc'd for $\text{C}_{12}\text{H}_7\text{NO}_2$ [M^+] 197.0477, found 197.0470.

Methyl 2-(2-hydroxy-3-oxindolin-2-yl)-2-methylpropanoate 84:

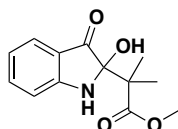

Isolated as a yellow oil; $R_f = 0.33$ (7:3 hexanes:EtOAc); IR (cast film) 3373, 2990, 2952, 1710, 1619, 1487, 1472 cm^{-1} ; ^1H NMR (500 MHz, CDCl_3) $\delta = 7.54$ (d, $J = 7.2$ Hz, 1H), 7.44 (t, $J = 7.6$ Hz, 1H), 6.83 (t, $J = 7.2$ Hz, 1H), 6.81 (d, $J = 8.1$ Hz, 1H), 5.05 (br s, 1H), 4.91 (br s, 1H), 3.79 (s, 3H), 1.30 (s, 3H), 1.29 (s, 3H); ^{13}C NMR (125 MHz, CDCl_3) $\delta = 200.1, 178.0, 160.4, 138.0, 125.1, 120.0, 112.46, 89.40, 52.73, 47.63, 21.17, 18.82$; HRMS calc'd for $\text{C}_{13}\text{H}_{15}\text{NO}_4$ [M^+] 249.1001, found 249.1000.

2-(1-Methoxy-2-methyl-1-oxopropan-2-yl)-3-oxo-3H-indole 1-oxide 85:

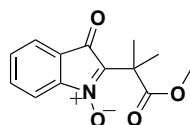

Isolated as a yellow oil. $R_f = 0.64$ (7:3 hexanes:EtOAc); IR (cast film) 2993, 2953, 1766, 1644, 1608, 1475, 1465 cm^{-1} ; ^1H NMR (500 MHz, CDCl_3) $\delta = 8.19$ (br d, $J = 8.4$ Hz, 1H), 7.82-7.78 (m, 1H), 7.61 (br d, $J = 8.1$ Hz, 1H), 7.54-7.50 (m, 1H), 3.73 (s, 3H), 1.65 (s, 3H), 1.64 (s, 3H); ^{13}C NMR (125 MHz, CDCl_3) $\delta = 173.4$,

162.8, 159.3, 146.1, 136.4, 128.6, 128.4, 127.2, 117.0, 52.8, 49.3, 23.5 (x2); HRMS calc'd for C₁₃H₁₃NO₄ [M⁺] 247.0845, found 247.0844.

Methyl 3-(2-azidophenyl)3-oxopropanoate **86:**

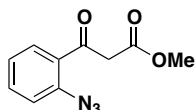

Dichloromethane (10 ml) was added to a conical flask containing 2-azido benzoic acid¹⁹ (350 mg, 2.2 mmol) and the suspension was cooled to 0 °C before addition of methyl acetate (175 μ L, 2.2 mmol) and trichloroacetyl chloride (290 μ L, 2.6 mmol). This solution was slowly transferred *via* cannula to a suspension of NaH (60 % dispersion in oil, 105 mg, 2.6 mmol) in DCM (3 mL) at 0 °C. After stirring at 0 °C for 15 min the solution was cooled to -45 °C before the addition of 1-methylimidazole (205 μ L, 2.6 mmol). The solution was stirred for an additional 10 minutes at -45 °C before slowly adding TiCl₄ (825 μ L, 7.5 mmol) followed by NBU₃ (2 mL, 8.4 mmol). The dark red/brown solution was kept at -45 °C for 30 minutes before being warmed to 0°C and subsequently quenched with water (10 mL). The organic layer was separated and the aqueous washed 3x with equal portions of Et₂O. The combined organic layers were washed with an equivalent volume of water and brine, dried over MgSO₄, filtered, and concentrated under reduced pressure. The crude product was purified by flash chromatography (silica gel, 1:4 hexanes:EtOAc) to afford 322 mg (68 %) of **86** as a pale yellow oil.

86: R_f = 0.6 (7:3 hexanes:EtOAc); IR (cast film) 2953, 2128, 1746, 1680, 1650, 1627, 1480, 1449, 1289, 1254, 1203 cm⁻¹; ¹H NMR (500 MHz, CDCl₃) *as a 4:1 mixture of keto:enol tautomers* δ (keto) = 7.84 (ddd, *J* = 0.5, 1.6, 7.8 Hz, 1H), 7.59 (ddd, *J* = 1.7, 7.3, 8.1 Hz, 1H), 7.27-7.22 (m, 2H), 4.11 (s, 2H), 3.77 (s, 3H); δ (enol) = 7.78 (dd, *J* = 1.6, 7.8 Hz, 1H), 7.48 (ddd, *J* = 1.6, 7.3, 8.1 Hz, 1H), 7.27-7.22 (m, 2H), 5.88 (s, 1H), 3.84 (s, 3H) *enol proton not detected*; ¹³C NMR (125 MHz, CDCl₃) *as a mixture of keto:enol tautomers* δ = 192.9, 173.4, 168.7, 168.1, 139.1, 137.9, 133.9, 131.6, 131.1, 129.9, 129.4, 125.7, 125.0, 124.8, 119.2,

119.1 92.6, 52.3, 51.6, 49.6; HRMS calc'd for $C_{10}H_9N_3O_3Na$ $[M + Na]^+$ 242.0536, found 242.0536.

Methyl 3-(2-azidophenyl)-2-diazo-3-oxopropanoate 87:

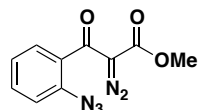

Triethylamine (715 μ L, 5.1 mmol) was added to a stirred solution of keto-ester **86** (1.02 g, 4.65 mmol) in CH_3CN (19 ml). Tosyl azide (916 mg, 4.65 mmol) in CH_3CN (9 mL) was transferred *via* cannula into the flask and the reaction was left to stir overnight. Concentration under reduced pressure followed by purified *via* flash chromatography (silica gel, 17:3 hexanes:EtOAc) resulted in a quantitative yield of **87** (1.14g) as a pale yellow solid. To prevent decomposition the product was stored under Ar in the freezer in a foil wrapped flask. Under these conditions the compound was stable over several months.

87: m.p. = 76-78 $^{\circ}C$; R_f = 0.54 (7:3 hexanes:EtOAc); IR (cast film) 2956, 2132, 1729, 1700, 1633, 1597, 1486, 1446, 1438, 1334, 1316, 1287 cm^{-1} ; 1H NMR (500 MHz, $CDCl_3$) δ = 7.54-7.52 (m, 1H), 7.34 (dd, J = 1.5, 7.8 Hz, 1H), 7.28-7.21 (m, 2H), 3.79 (s, 3H); ^{13}C NMR (125 MHz, $CDCl_3$) δ = 185.7, 160.9, 137.7, 137.5, 131.9, 130.3, 128.4, 124.8, 118.3, 52.3; HRMS calc'd for $C_{10}H_7N_5O_3$ $[M^+]$ 245.0549, found 245.0549.

Methyl 2-(2-methoxy-2-oxoethyl)-3-oxoindoline-2-carboxylate 88:

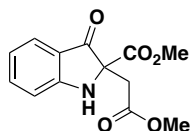

A solution of diazo-azide **87** (60 mg, 0.24 mmol) in toluene (6 mL) was added to a solution of [(1-methoxyethenyl)oxy]trimethylsilane **72** (105 μ L, 0.48 mmol) and $Cu(hfacac)_2$ (11.2 mg, 0.023 mmol) in toluene (6 mL) at reflux *via* syringe pump over 1h. The reaction mixture turned dark brown over the course of the addition. Once the addition was complete the reaction was monitored by TLC for

consumption of the diazo-azide starting material. Upon consumption of **87**, the reaction mixture was cooled to room temperature and then washed with an equivalent volume of 0.5 M aqueous solution of K_2CO_3 and brine. The combined organic layers were then dried over $MgSO_4$, filtered, concentrated under reduced pressure and purified by flash chromatography (silica gel, 4:1 hexanes:EtOAc) to yield 56 mg (89 %) of **88** as a yellow oil.

88: $R_f = 0.3$ (7:3 hexanes:EtOAc); IR (cast film) 3377, 2955, 1743, 1617, 1488, 1469, 1214 cm^{-1} ; 1H NMR (500 MHz, $CDCl_3$) $\delta = 7.60$ (br d, $J = 7.8$ Hz, 1H), 7.52-7.48 (m, 1H), 6.97 (dd, $J = 0.7, 7.5$ Hz, 1H), 6.91-6.88 (m, 1H), 5.61 (br s, 1H), 3.74 (s, 3H), 3.72 (s, 3H), 3.55 (d, $J = 17.4$ Hz, 1H), 2.57 (d, $J = 17.4$ Hz, 1H); ^{13}C NMR (125 MHz, $CDCl_3$) $\delta = 194.0, 171.5, 167.8, 161.8, 138.0, 125.4, 120.3, 119.2, 113.3, 71.53, 53.6, 52.2, 39.6$; HRMS calc'd for $C_{13}H_{13}NO_5$ [M^+] 263.0794, found 263.0794.

Methyl 2-(1-methoxy-2-methyl-2-oxoethyl)-3-oxoindoline-2-carboxylate 89:

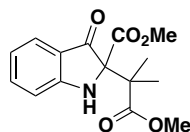

A solution of diazo-azide **87** (56 mg, 0.23 mmol) in toluene (6 mL) was added to a solution of *tert*-butyl(1-methoxy-2-methyl-1-propenyloxy)dimethylsilane (**74**) (93 μ L, 0.46 mmol) and $Cu(hfacac)_2$ (10.6 mg, 0.022 mmol) in toluene (6 mL) at reflux *via* syringe pump over 1h. Upon consumption of **87**, the reaction mixture turned dark brown over the course of the addition. Once the addition of the substrate was complete the reaction was monitored by TLC for consumption of the diazo-azide starting material. The reaction mixture was cooled to room temperature and then washed with an equivalent volume of 0.5 M aqueous solution of K_2CO_3 and brine. The combined organic layers were then dried over $MgSO_4$, filtered, concentrated under reduced pressure and purified by flash chromatography (silica gel, 4:1 hexanes:EtOAc) to yield 32 mg (48 %) of **89** as a yellow oil.

89: $R_f = 0.38$ (7:3 hexanes:EtOAc); IR (cast film) 3373, 2994, 2954, 1743, 1617, 1488, 1471, 1281, 1252, 1196, 1149 cm^{-1} ; ^1H NMR (500 MHz, CDCl_3) $\delta = 7.60$ (br d, $J = 7.7$ Hz, 1H), 7.49 (ddd, $J = 1.3, 7.1, 7.7$ Hz, 1H), 6.95 (br d, $J = 8.3$ Hz, 1H), 6.88 (dt, $J = 0.8, 7.4$ Hz, 1H), 5.90 (s, 1H), 3.76 (s, 3H), 3.67 (s, 3H), 1.59 (s, 3H), 1.28 (s, 3H); ^{13}C NMR (125 MHz, CDCl_3) $\delta = 194.8, 176.5, 168.4, 160.9, 137.6, 124.9, 121.3, 119.9, 112.8, 75.4, 53.3, 52.4, 49.6, 21.0, 20.1$; HRMS calc'd for $\text{C}_{15}\text{H}_{17}\text{NO}_5$ [M^+] 291.1107, found 291.1106.

2-tert-butyl 1,1-dimethyl 1-amino-2-diazoethane-1,1,2-tricarboxylate 98:

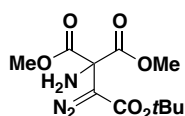

A solution of sodium azide in DMSO (1.1 mL, 0.55 mmol) was added to 177 mg (0.54 mmol) of 1-bromo-2-(1,1-dimethylethyl)-1,1-dimethyl ester (**97**), which had been prepared a previously reported method,²² and was stirred overnight at room temperature. The reaction was diluted with 5 mL of water and extracted with DCM (3 x 5 mL). The combined organic layers were washed with water (2 x 5 mL) and brine (1 x 5 mL) then dried over MgSO_4 , filtered and concentrated under reduced pressure. Purification by flash chromatography (silica gel, 17:3 hexanes:EtOAc) yielded 65 mg (38 %) of **98** as a yellow oil as well as 58 mg of recovered starting material.

98: $R_f = 0.21$ (7:3 hexanes:EtOAc); IR (cast film) 3392, 3320, 2980, 2957, 2108, 1752, 1693, 1457, 1436, 1370, 1321, 1256, 1151 cm^{-1} ; ^1H NMR (500 MHz, CDCl_3) $\delta = 3.83$ (s, 6H), 2.49 (br s, 2H), 1.48 (s, 9H); ^{13}C NMR (125 MHz, CDCl_3) $\delta = 169.2, 164.8, 82.4, 64.2, 53.7, 28.3, 27.8$; HRMS calc'd for $\text{C}_{11}\text{H}_{17}\text{N}_3\text{O}_6\text{Na}$ [$\text{M}+\text{Na}$]⁺ 310.101, found 310.1006.

4-Azido-3,3-dimethylbutane-2-one 100:

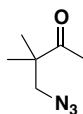

A solution of 0.5M NaN₃ in DMSO (19mL, 9.5 mmol) was added to a conical flask containing mesylate **105**²⁴ (1.50g, 7.7 mmol). Once thoroughly mixed the solution was divided up into several 2-5 mL microwave vials and irradiated at 180 °C for 15 minutes. Once cooled the reactions were combined, diluted with 20 mL of water and extracted with DCM (3 x 50 mL). The combined organic layers were washed with water (2 x 50 mL) and brine (1 x 50 mL) then dried over MgSO₄, filtered and concentrated under reduced pressure to give 895 mg (82 %) of **100** as a colourless oil which could be used in the subsequent reactions without purification.

100: R_f = 0.20 (7:3 hexanes:EtOAc); IR (cast film) 2974, 2936, 2875, 2106, 1709, 1471, 1309, 1357, 1274, 1130 cm⁻¹; ¹H NMR (500 MHz, CDCl₃) δ = 3.43 (s, 2H), 2.19 (s, 3H), 1.21 (s, 6H); ¹³C NMR (125 MHz, CDCl₃) δ = 211.5, 59.1, 48.6, 25.5, 22.6; HRMS for this compound was attempted by several different methods but no peak for [M⁺] could be obtained. In all cases the m/z = 100 peak observed was C₆H₁₁O [M-N₃]⁺ calc'd at 99.0810, found 99.0809.

Z-5-Azido-1-hydroxy-4,4-dimethyl-1-phenylpent-1-ene-3-one 103:

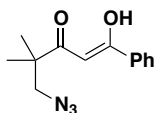

A solution of azide **100** (518 mg, 3.7 mmol) in THF (3.7 mL) was added dropwise to a freshly prepared solution of LDA (1.1 mmol, 1M in THF) at -78 °C. After stirring at -78 °C for 1h a solution of benzoyl cyanide (491 mg, 3.7 mmol) in THF (7.5 mL) was added slowly *via* cannula. The reaction was kept at -78 °C and monitored for consumption of starting material by TLC. When the reaction was complete (~ 1h) the reaction was warmed to 0 °C before quenching with sat'd aq. NH₄Cl (10 mL). The reaction was allowed to warm to room temperature then extracted with 2 x 10 mL of Et₂O. The combined organic layers were washed with water (10 mL) and brine (10 mL) then dried over MgSO₄, filtered and

concentrated under reduced pressure. Purification by flash chromatography (silica gel, 9:1 hexanes:EtOAc) yielded 744 mg (82 %) of **103** as a yellow oil.

103: $R_f = 0.64$ (4:1 hexanes:EtOAc); IR (neat)*keto form* 2973, 2934, 2871, 2102, 1714, 1602, 1570, 1473, 1277 cm^{-1} ; ^1H NMR (500 MHz, CDCl_3) $\delta = 7.94$ -9.92 (m, 2H), 7.57 (tt, $J = 1.5, 7.2$ Hz, 1H), 7.51-7.48 (m, 2H), 6.33 (s, 1H), 3.52 (s, 2H), 1.31 (s, 6H) *enol proton not detected*; ^{13}C NMR (125 MHz, CDCl_3) $\delta = 199.2, 184.8, 135.1, 132.5, 128.7, 127.1, 93.2, 59.6, 44.6, 23.5$; HRMS calc'd for $\text{C}_{13}\text{H}_{16}\text{N}_3\text{O}_2$ $[\text{M}+\text{H}]^+$ 246.1237, found 246.1236.

5-Azido-2-diazo-4,4-dimethyl-1-phenylpentane-1,3-dione **99**:

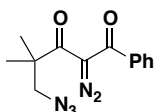

Triethylamine (370 μL , 2.65 mmol) was added to a stirred solution of compound **100** (580 mg, 2.36 mmol) in CH_3CN (9.5 ml). Tosyl azide (470 mg, 2.38 mmol) in CH_3CN (2.5 mL) was transferred *via* cannula into the flask and the reaction was left to stir overnight. After washing with an equivalent volume of water and brine the organic layer was dried over MgSO_4 , filtered and concentrated under reduced pressure. Purification by flash chromatography (silica gel, 19:1 hexanes:EtOAc) resulted in a 99 % yield of **99** (631 mg) as a yellow oil.

99: $R_f = 0.77$ (4:1 hexanes:EtOAc); IR (cast film) 2971, 2932, 2105, 1644, 1295, 1266 cm^{-1} ; ^1H NMR (500 MHz, CDCl_3) $\delta = 7.65$ -7.62 (m, 2H), 7.57-7.55 (m, 1H), 7.50-7.46 (m, 2H), 3.67 (s, 2H), 1.39 (s, 6H); ^{13}C NMR (125 MHz, CDCl_3) $\delta = 195.6, 185.2, 137.0, 133.0, 128.9, 127.5, 85.5, 58.6, 49.2, 21.5$; HRMS calc'd for $\text{C}_{13}\text{H}_{13}\text{N}_5\text{O}_2$ $[\text{M}^+]$ 271.1069, found 271.1050.

2-Benzoyl-4,4-dimethyl-4,5-dihydropyrrol-3-one **105**:

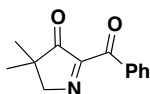

Toluene (25 mL) was added to a flask containing diazo-azide **99** (273mg, 1 mmol) and Cu(hfacac)₂ (43 mg, 0.09 mol). Once the solution was heated to reflux the reaction was complete within 5 minutes. The reaction mixture was cooled to room temperature and then washed with an equivalent volume of 0.5 M aqueous solution of K₂CO₃ and brine. The organic layer was then dried over MgSO₄, filtered, concentrated under reduced pressure and purified by flash chromatography (silica gel, 4:1 hexanes:EtOAc) to yield 205 mg (95 %) of **105** as a viscous yellow oil.

105: R_f = 0.27 (4:1 hexanes:EtOAc); IR (cast film) 2964, 2929, 1744, 1670, 1597, 1465, 1450, 1335, 1310, 1222 cm⁻¹; ¹H NMR (500 MHz, CDCl₃) δ = 8.06-8.04 (m, 2H), 7.69-7.66 (m, 1H), 7.53 (t, J = 7.9 Hz, 2H), 4.36 (s, 2H), 1.26 (s, 6H); ¹³C NMR (125 MHz, CDCl₃) δ = 203.9, 189.8, 168.0, 134.8, 134.6, 129.9, 128.8, 71.2, 42.8, 23.5; HRMS calc'd for C₁₃H₁₃NO₂ [M⁺] 215.0946, found 215.0941.

2-Benzoyl-1-ethyl-4,4-dimethylpyrrolidin-3-one **106**:

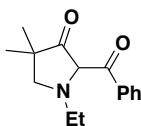

Diethylzinc (1.2 mL, 1.0M in hexanes) was added slowly added to a solution of **105** (58 mg, 0.27 mmol) in THF (2.7 mmol) at -78 °C. The solution was slowly warmed to room temperature, which induced a colour change to a deep orange/red. The reaction was monitored for consumption of starting material by TLC. When the reaction was complete (~ 30 min) the reaction was quenched with sat'd aq. NH₄Cl (1 mL). The reaction was diluted with Et₂O (5 mL) and washed with water (5 mL) before extracting with 1 M HCl (3 x 5 mL). The combined acidic aqueous layers were basified with 3 M NaOH (aq) until pH ≈ 12, at which point the solution changed from colourless to deep yellow in colour. The basified solution was extracted with DCM (3 x 10 mL). The combined organic layers were washed with an equivalent amount of water and brine, dried over MgSO₄, filtered and concentrated under reduced pressure to yield 53 mg of a crude yellow solid found by ¹NMR to contain a mixture of compound **106** and

107 as well as benzoic acid. Attempts to isolate **106** were not successful due to its rapid conversion to **107** and benzoic acid.

106: ^1H NMR (500 MHz, CDCl_3) δ = 8.10-8.07 (m, 2H), 7.72-7.56 (m, 1H), 7.51-7.46 (m, 2H), 4.54 (s, 1H), 3.38 (d, J = 9.0 Hz, 1H), 2.77-2.63 (m, 2H), 2.56 (d, J = 9.0 Hz, 1H), 1.27 (s, 3H), 1.18 (s, 3H), 1.08 (t, J = 7.7 Hz, 3H).

1-Ethyl-4,4-dimethylpyrrolidine-2,3-dione 107:

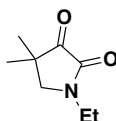

107: IR (cast film) cm^{-1} ; ^1H NMR (500 MHz, CDCl_3) δ = 3.61 (q, J = 7.5 Hz, 2H), 3.43 (s, 2H), 1.28 (s, 6H), 1.27 (7, J = 7.5 Hz, 3H); ^{13}C NMR (125 MHz, CDCl_3) δ = 203.9, 159.0, 55.5, 40.0, 39.2, 23.8, 12.1; HRMS calc'd for $\text{C}_{13}\text{H}_{13}\text{NO}_2$ [M^+] 215.0946, found 215.0941.

4.7. References

1. Clark, J. S., *Nitrogen, Oxygen and Sulfur Ylide Chemistry*. Oxford University Press: New York, 2002.
2. Padwa, A.; Hornbuckle, S. F., *Chem. Rev.* **1991**, *91*, 263-309.
3. Doyle, M. P.; McKervey, M. A.; Ye, T., *Modern Catalytic Methods for Organic Synthesis with Diazo Compounds: From Cyclopropanes to Ylides*. Wiley-Interscience: New York, 1998.
4. Doyle, M. P.; Tamblyn, W. H.; Bagheri, V., *J. Org. Chem.* **1981**, *46*, 5094-5102.
5. Vanecko, J. A.; Wan, H.; West, F. G., *Tetrahedron* **2006**, *62*, 1043-1062.
6. West, F. G.; Glaeske, K. W.; Naidu, B. N., *Synthesis* **1993**, 977-980.

7. (a) West, F. G.; Naidu, B. N., *J. Am. Chem. Soc.* **1993**, *115*, 1177-1178; (b) West, F. G.; Naidu, B. N., *J. Org. Chem.* **1994**, *59*, 6051-6056; (c) Bott, T. M.; Vanecko, J. A.; West, F. G., *J. Org. Chem.* **2009**, *74*, 2832-2836.
8. (a) West, F. G.; Naidu, B. N., *J. Am. Chem. Soc.* **1994**, *116*, 8420-8421; (b) Naidu, B. N.; West, F. G., *Tetrahedron* **1997**, *53*, 16565-16574; (c) Vanecko, J. A.; West, F. G., *Org. Lett.* **2002**, *4*, 2813-2816; (d) Glaeske, K. W.; Naidu, B. N.; West, F. G., *Tetrahedron Asymmetry* **2003**, *14*, 917-920; (e) Muroi, D.; Saba, A.; Culeddu, N., *Tetrahedron Asymmetry* **2004**, *15*, 2609-2614; (f) Vanecko, J. A.; West, F. G., *Org. Lett.* **2005**, *7*, 2949-2952.
9. (a) Clark, J. S.; Hodgson, P. B., *J. Chem. Soc., Chem. Commun.* **1994**, 2701-2702; (b) Clark, J. S.; Hodgson, P. B.; Goldsmith, M. D.; Street, L. J., *J. Chem. Soc., Perkin Trans. 1* **2001**, 3312-3324; (c) Heath, P.; Roberts, E.; Sweeney, J. B.; Wessel, H. P.; Workman, J. A., *J. Org. Chem.* **2003**, *68*, 4083-4086; (d) Roberts, E.; Sancon, J. P.; Sweeney, J. B.; Workman, J. A., *Org. Lett.* **2003**, *5*, 4775-4777; (e) Roberts, E.; Sancon, J. P.; Sweeney, J. B., *Org. Lett.* **2005**, *7*, 2075-2078.
10. (a) Padwa, A.; Weingarten, M. D., *Chem. Rev.* **1996**, *96*, 223-269; (b) Bartnik, R. Azomethine, carbonyl and thiocarbonyl ylides. 3.1 Generation of azomethine ylides from carbenes and carbenoids. In *Nitrogen, Oxygen and Sulfur Ylide Chemistry*, Clark, J. S., Ed.; Oxford University Press: New York, 2002; pp 187-196.
11. (a) Bartnik, R.; Mloston, G., *Tetrahedron* **1984**, *40*, 2569-2576; (b) A., P.; Dean, D. C.; Osterhout, M. H.; Precedo, L.; Semones, M. A., *J. Org. Chem.* **1994**, *59*, 5347; (c) Moran, M.; Bernardinelli, G.; Müller, P., *Helv. Chim. Acta* **1995**, *78*, 2048-2052.
12. Padwa, A.; Snyder, J. P.; Curtis, E. A.; Sheehan, S. M.; Worsencroft, K. J.; Kappe, C. O., *J. Am. Chem. Soc.* **2000**, *122*, 8155-8167.
13. Curtis, E. A.; Worsencroft, K. J.; Padwa, A., *Tetrahedron Lett.* **1997**, *38*, 3319-3322.

14. Kappe, C. O., *Tetrahedron Lett.* **1997**, *38*, 3323-3326.
15. (a) Ibata, T.; Fukushima, K. Generation of nitrile ylides by the reaction of carbenes or carbenoids with nitriles. In *Nitrogen, Oxygen and Sulfur Ylide Chemistry*, Clark, J. S., Ed.; Oxford University Press: Oxford, 2002; (b) Escolano, C.; Duque, M. D.; Vazquez, S., *Curr. Org. Chem.* **2007**, *11*, 741-772.
16. Kirmse, W.; Arold, H., *Chem. Ber.* **1968**, *101*, 1008-1012.
17. Blond, A.; Moumne, R.; Begis, G.; Pasco, M.; Lecourt, T.; Micouin, L., *Tetrahedron Lett.* **2011**, *52*, 3201-3203.
18. Bräse, S.; Gil, C.; Knepper, K.; Zimmermann, V., *Angew. Chem. Int. Ed.* **2005**, *44*, 5188-5240.
19. More, S. S.; Shanmughapriya, D.; Lingam, Y.; Patel, N. B., *Synth. Commun.* **2009**, *39*, 2058-2066.
20. Okuma, K.; Matsunaga, N.; Nagahora, N.; Shioji, K.; Yokomori, Y., *Chem. Commun.* **2011**, *47*, 5822-5824.
21. Misaki, T.; Nagase, R.; Matsumoto, K.; Tanabe, Y., *J. Am. Chem. Soc.* **2005**, *127*, 2854-2855.
22. Scott, D. M.; McPhail, A. T.; Porter, N. A., *Tetrahedron Lett.* **1990**, *31*, 1679-1682.
23. Benati, L.; Nanni, D.; Spagnolo, P., *J. Org. Chem.* **1999**, *64*, 5132-5138.
24. Boeykens, M.; De Kimpe, N.; Abbaspour Tehrani, K., *J. Org. Chem.* **1994**, *59*, 6973-6985.
25. (a) Yijima, C.; Hino, F.; Suda, K., *Synthesis* **1981**, 610-611; (b) Garcia-Valverde, M.; Pedrosa, R.; Vicente, M., *Synlett* **2002**, 2092-2094.

26. (a) Dickstein, J. S.; Fennie, M. W.; Norman, A. L.; Paulose, B. J.; Kozlowski, M. C., *J. Am. Chem. Soc.* **2008**, *130*, 15794-15795; (b) Dickstein, J. S.; Kozlowski, M. C., *Chem. Soc. Rev.* **2008**, *37*, 1166-1173.
27. Higuchi, K.; Sato, Y.; Tsuchimochi, M.; Sugiura, K.; Hatori, M.; Kawasaki, T., *Org. Lett.* **2009**, *11*, 197-199.
28. Karadeolian, A.; Kerr, M. A., *J. Org. Chem.* **2010**, *75*, 6830-6841.
29. (a) Boger, D. L.; McKie, J. A.; Nishi, T.; Ogiku, T., *J. Am. Chem. Soc.* **1996**, *118*, 2301-2302; (b) Boger, D. L.; McKie, J. A.; Nishi, T.; Ogiku, T., *J. Am. Chem. Soc.* **1997**, *119*, 311-325.

Appendix I: Selected NMR Spectra from Chapter 1

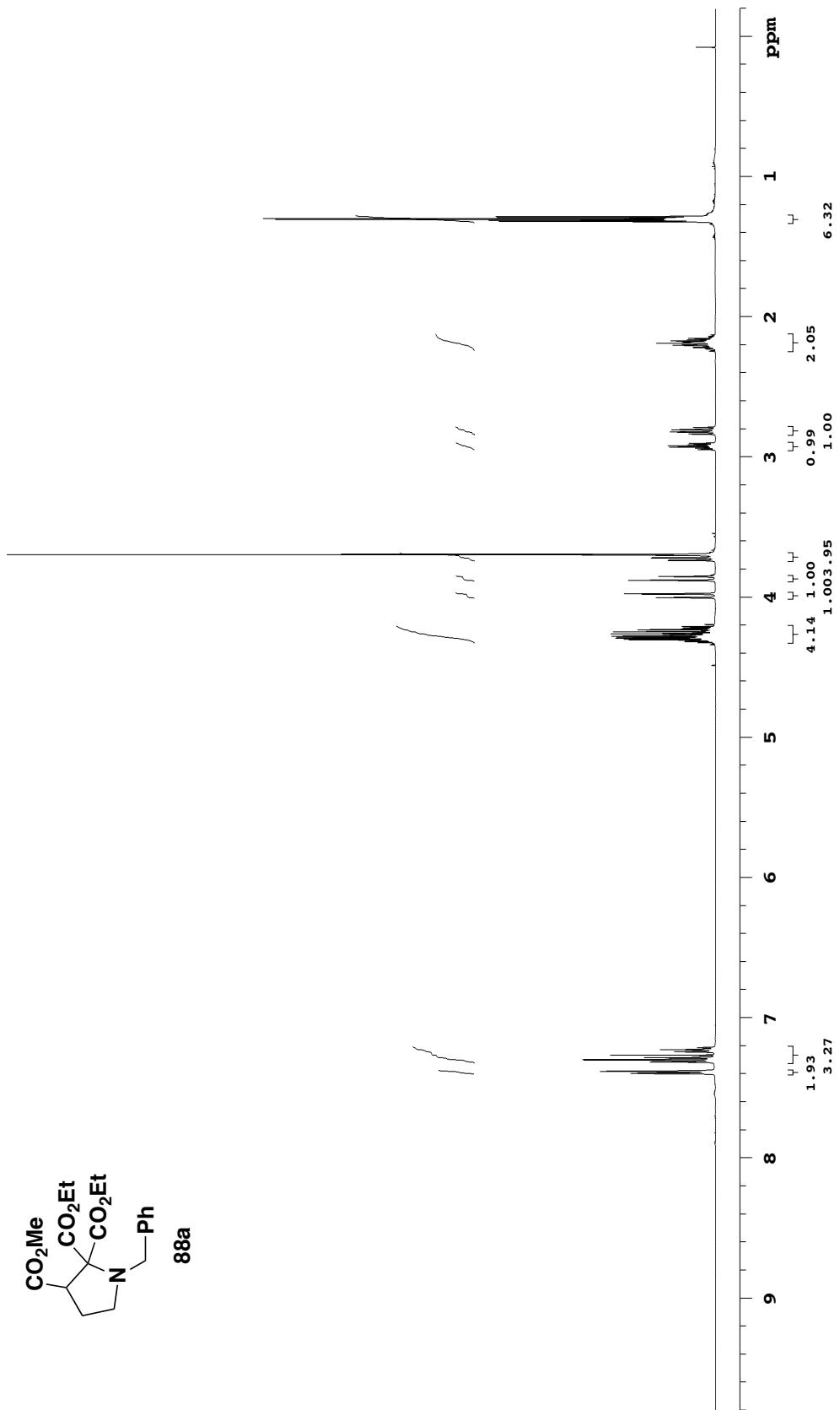
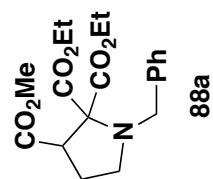

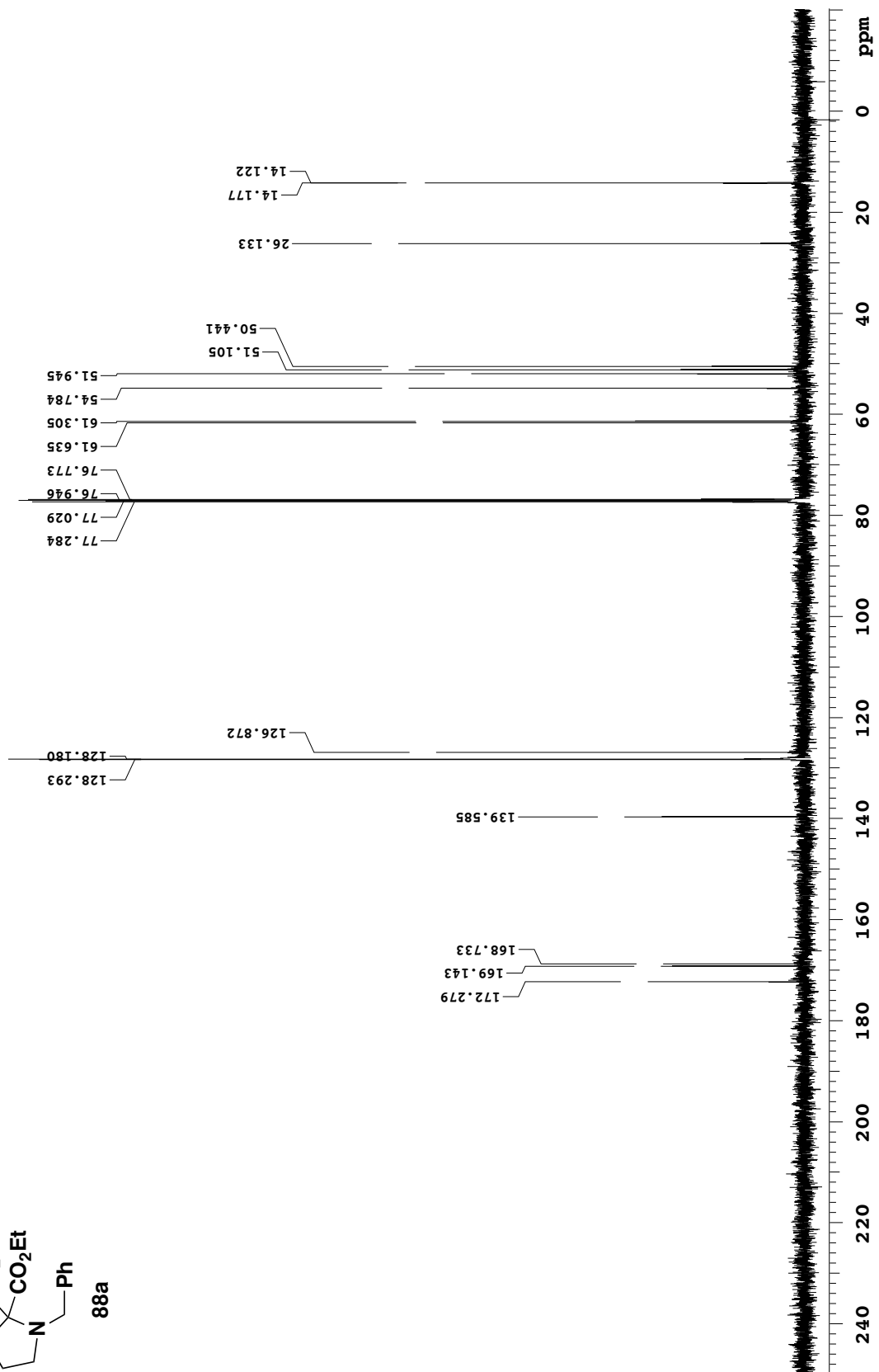
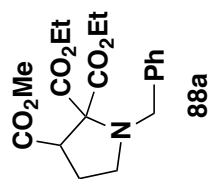

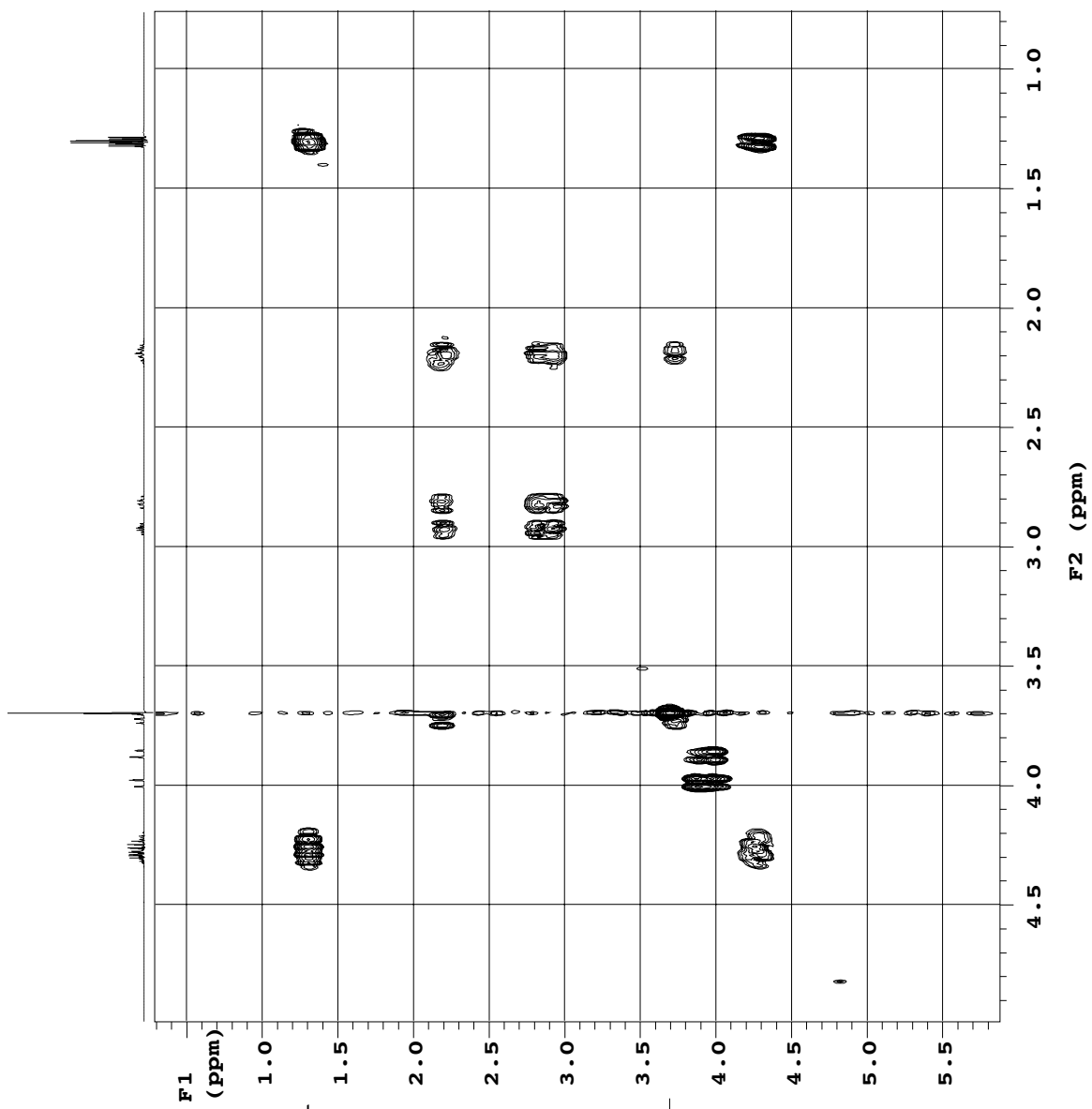
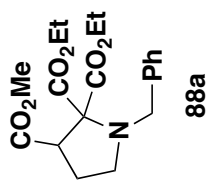

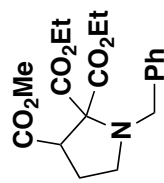

88a

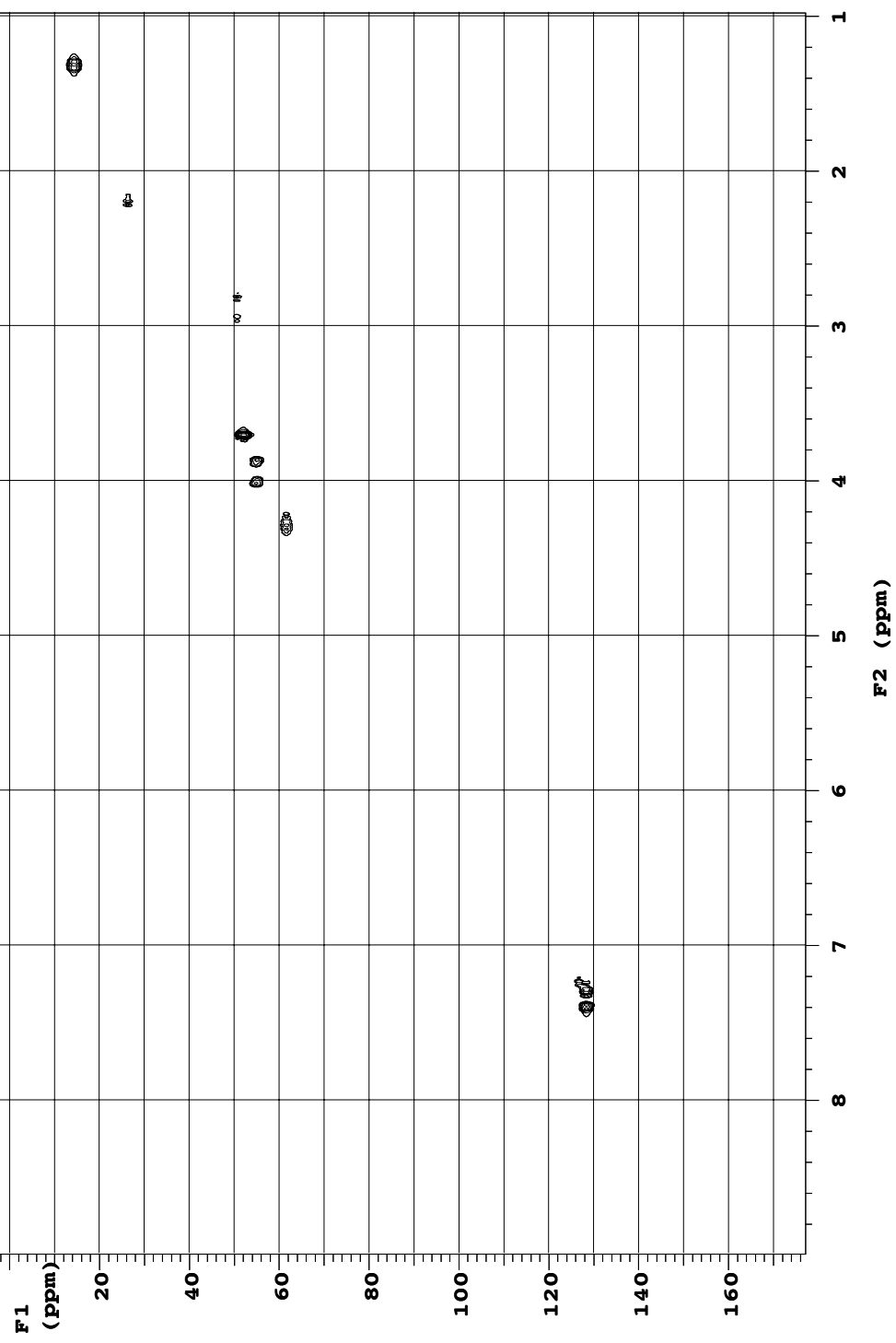

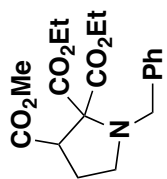

88a

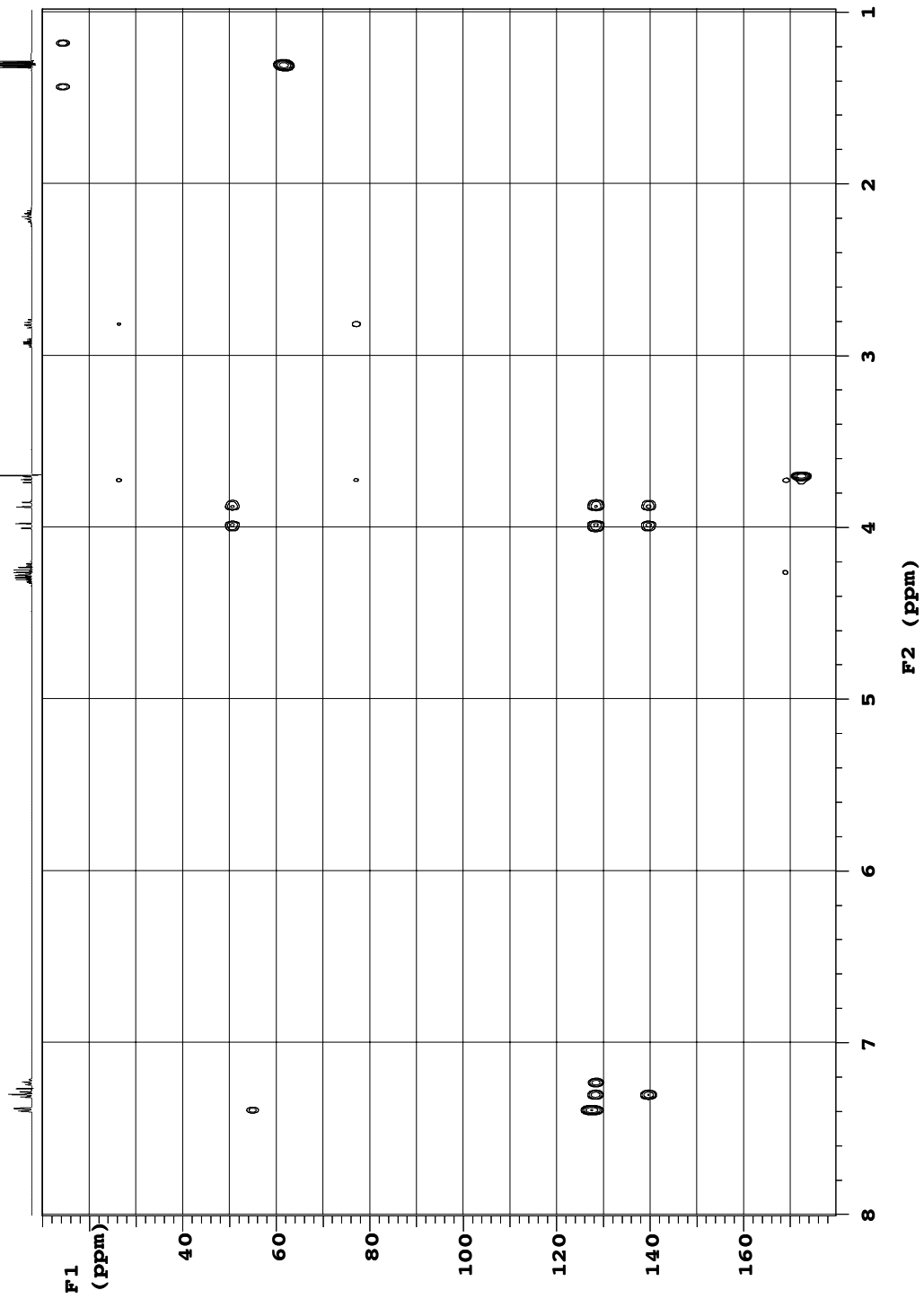

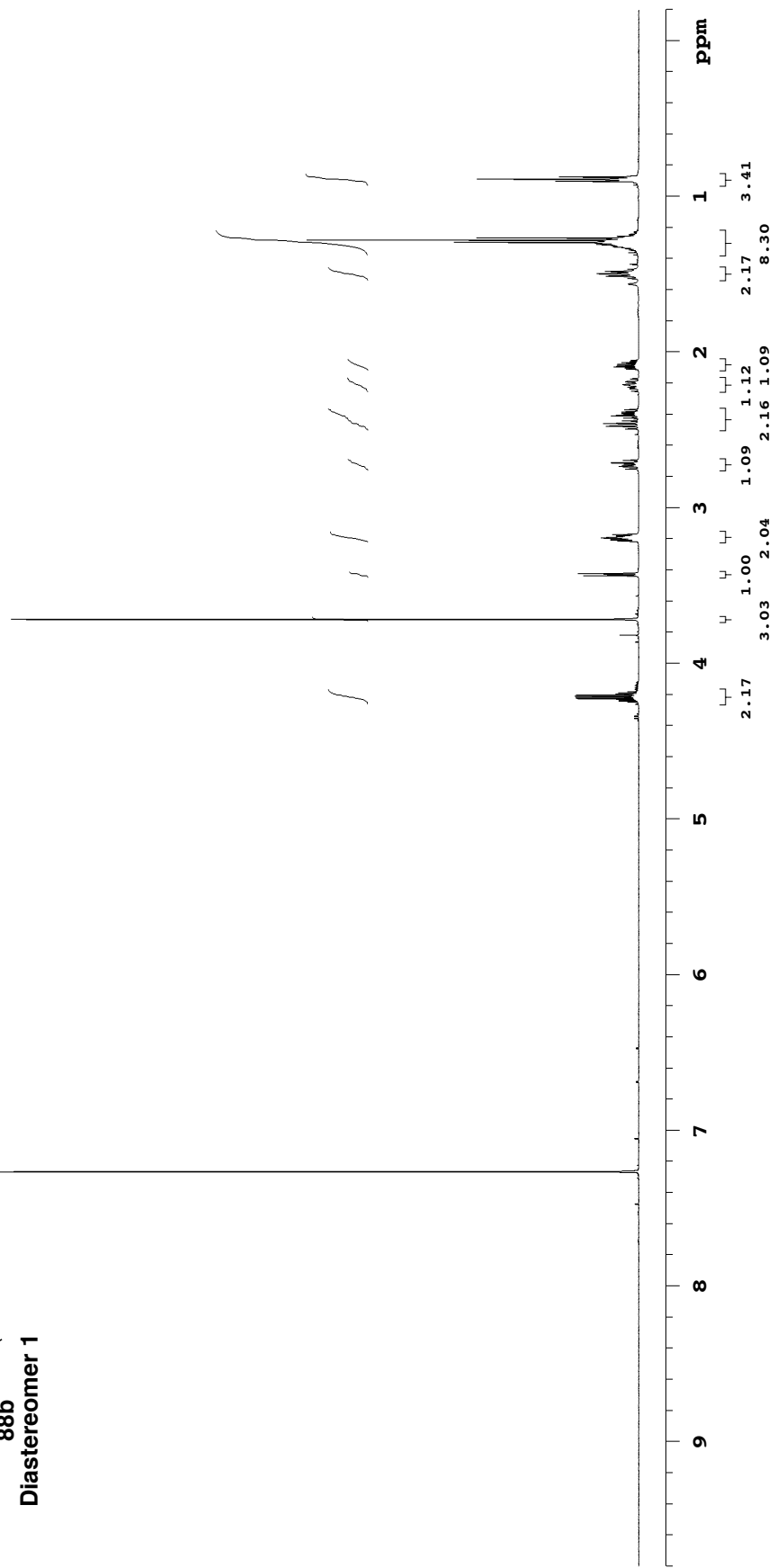
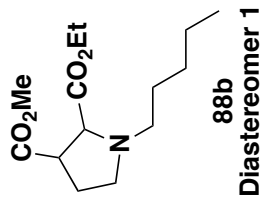

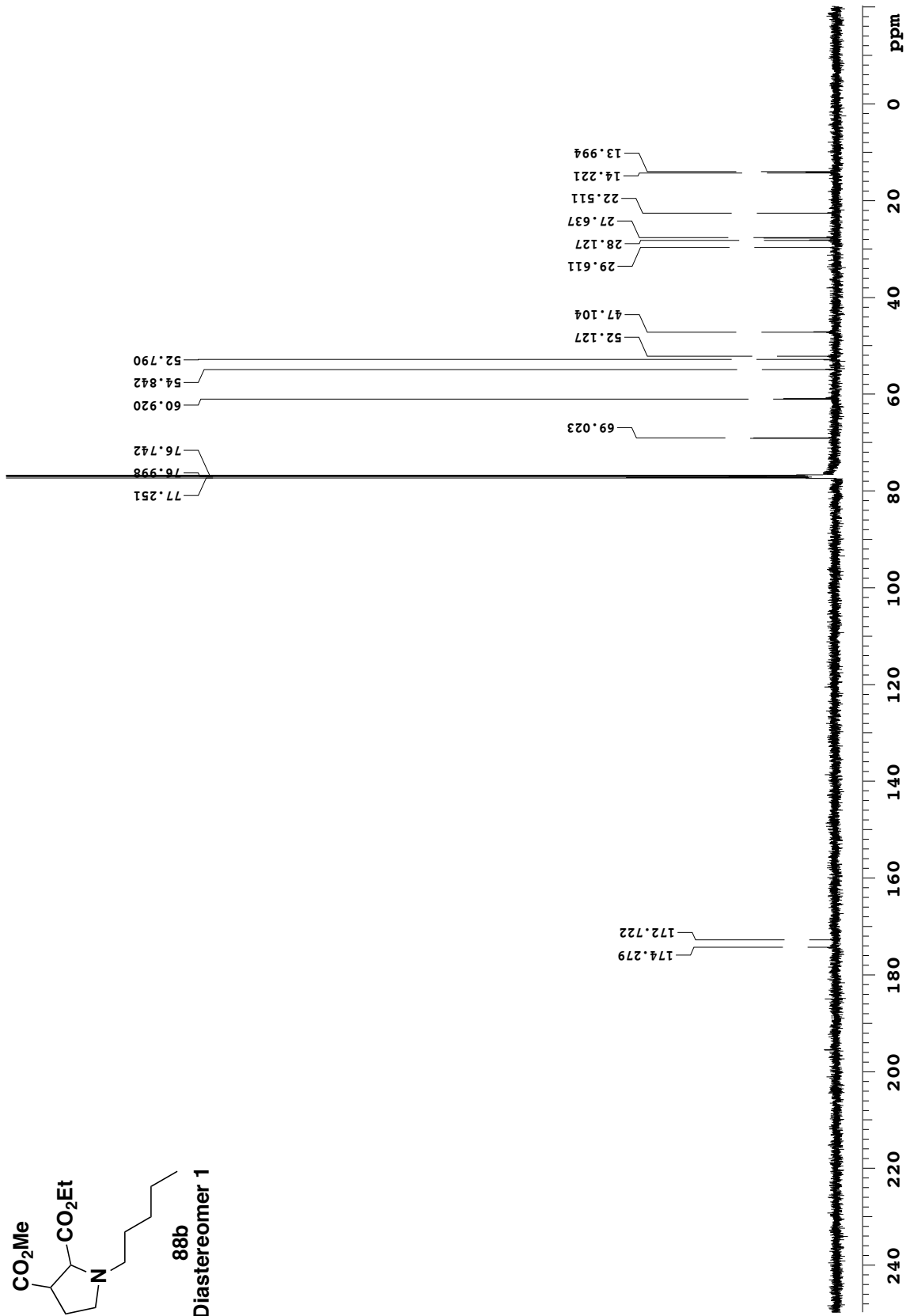
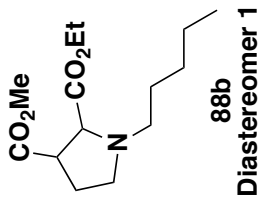

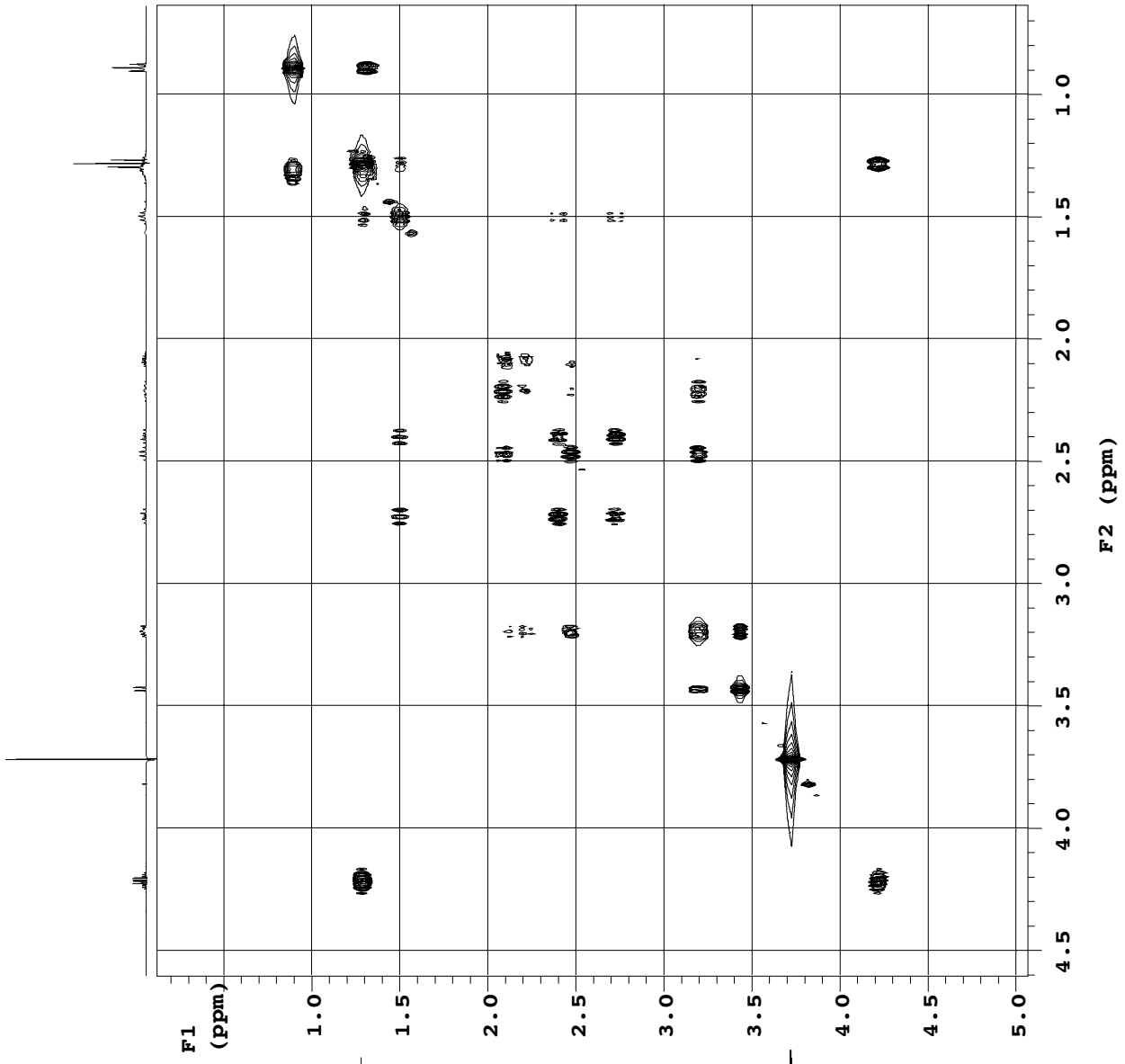
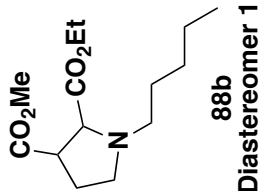

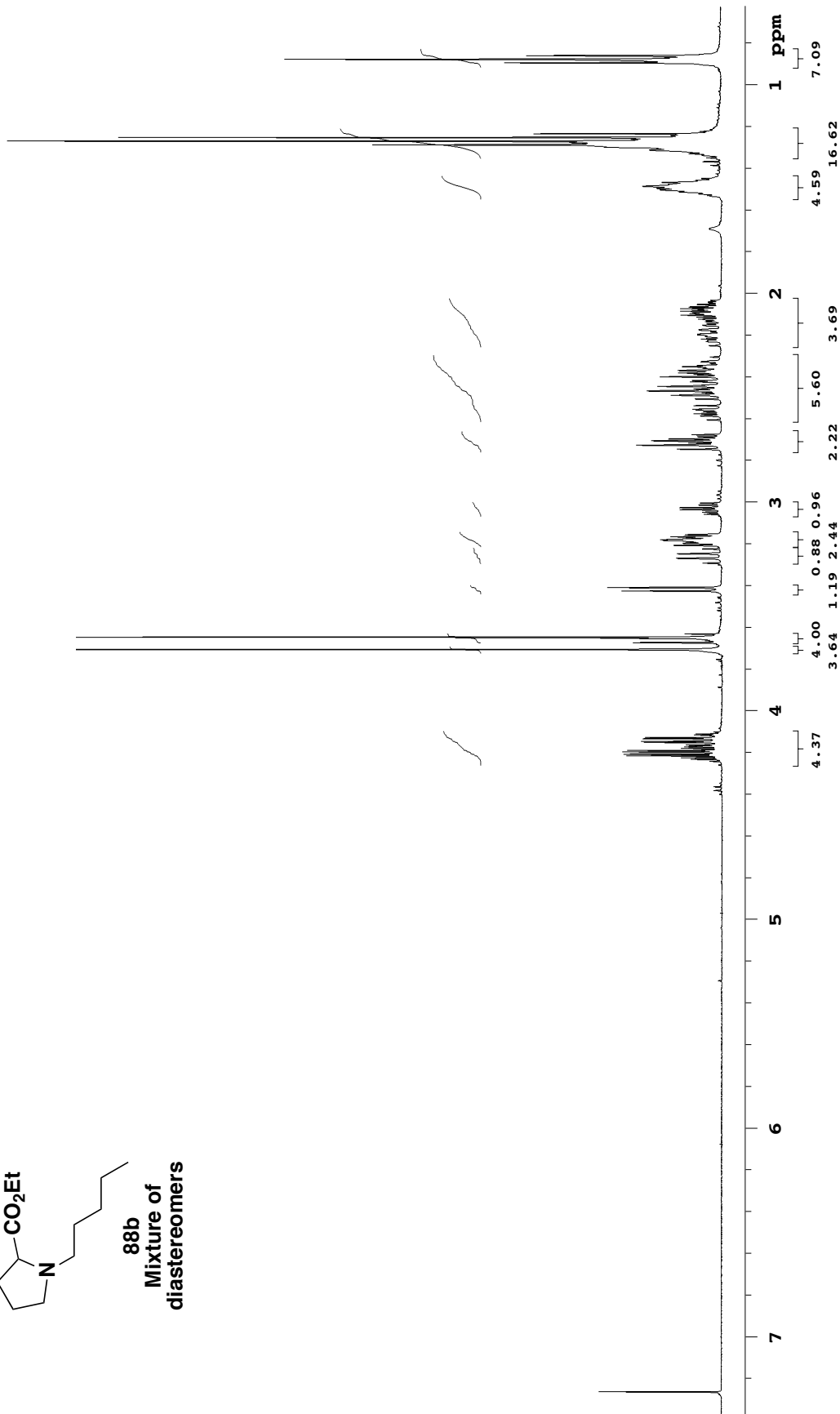
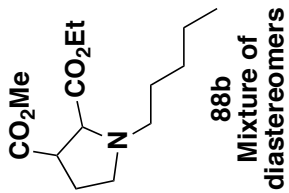

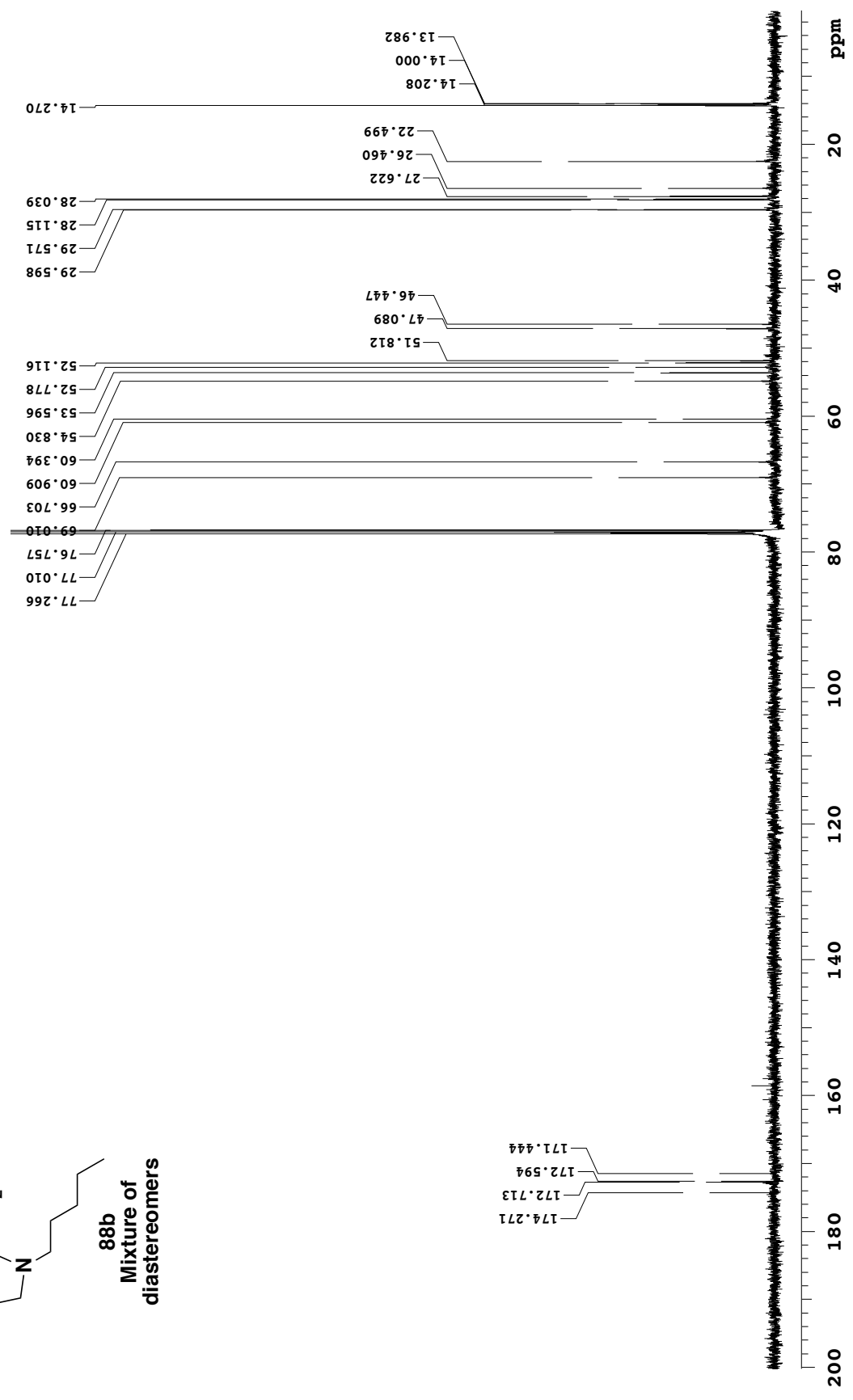
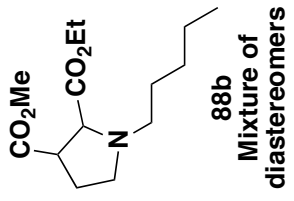

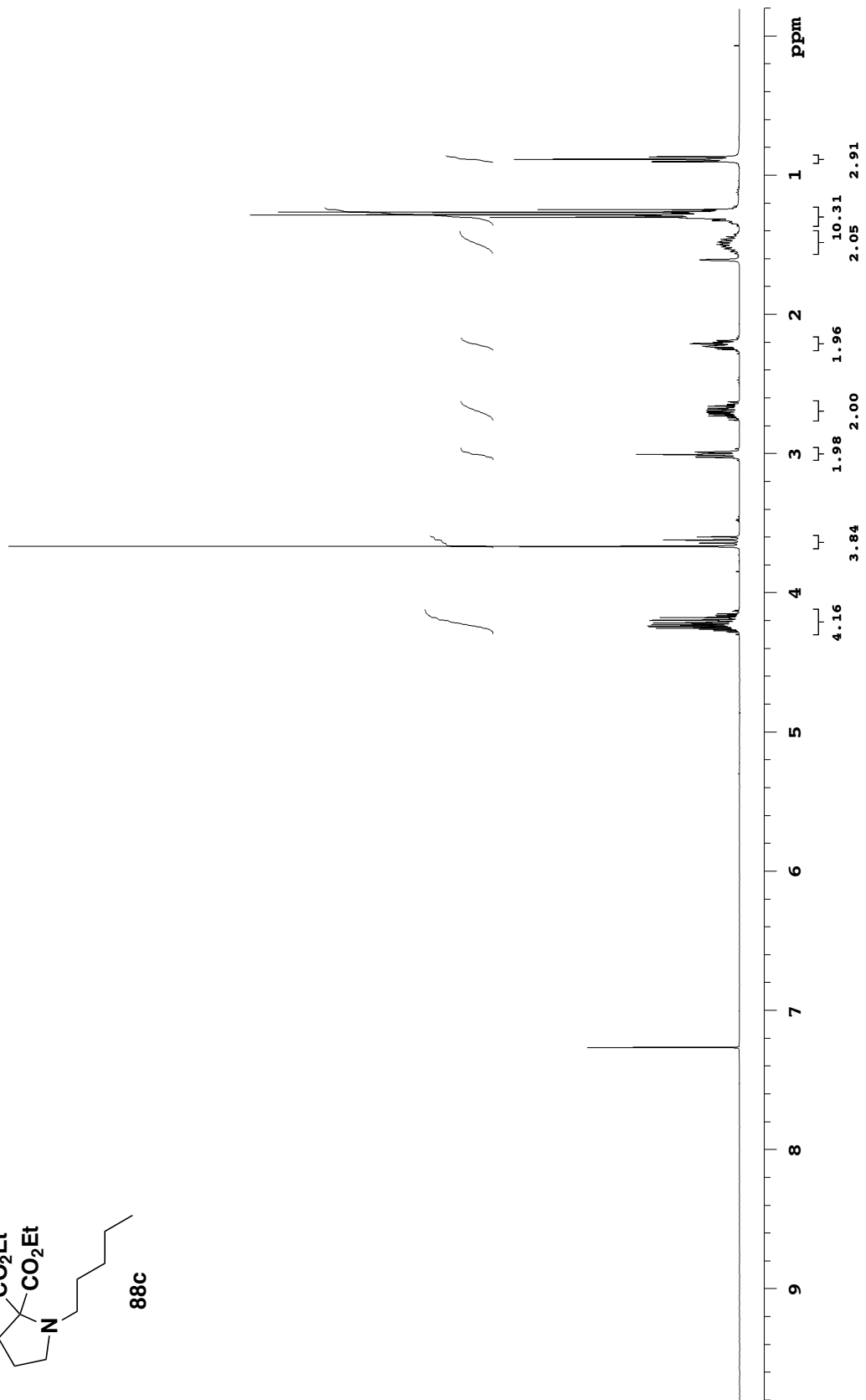
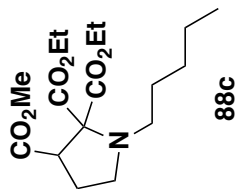

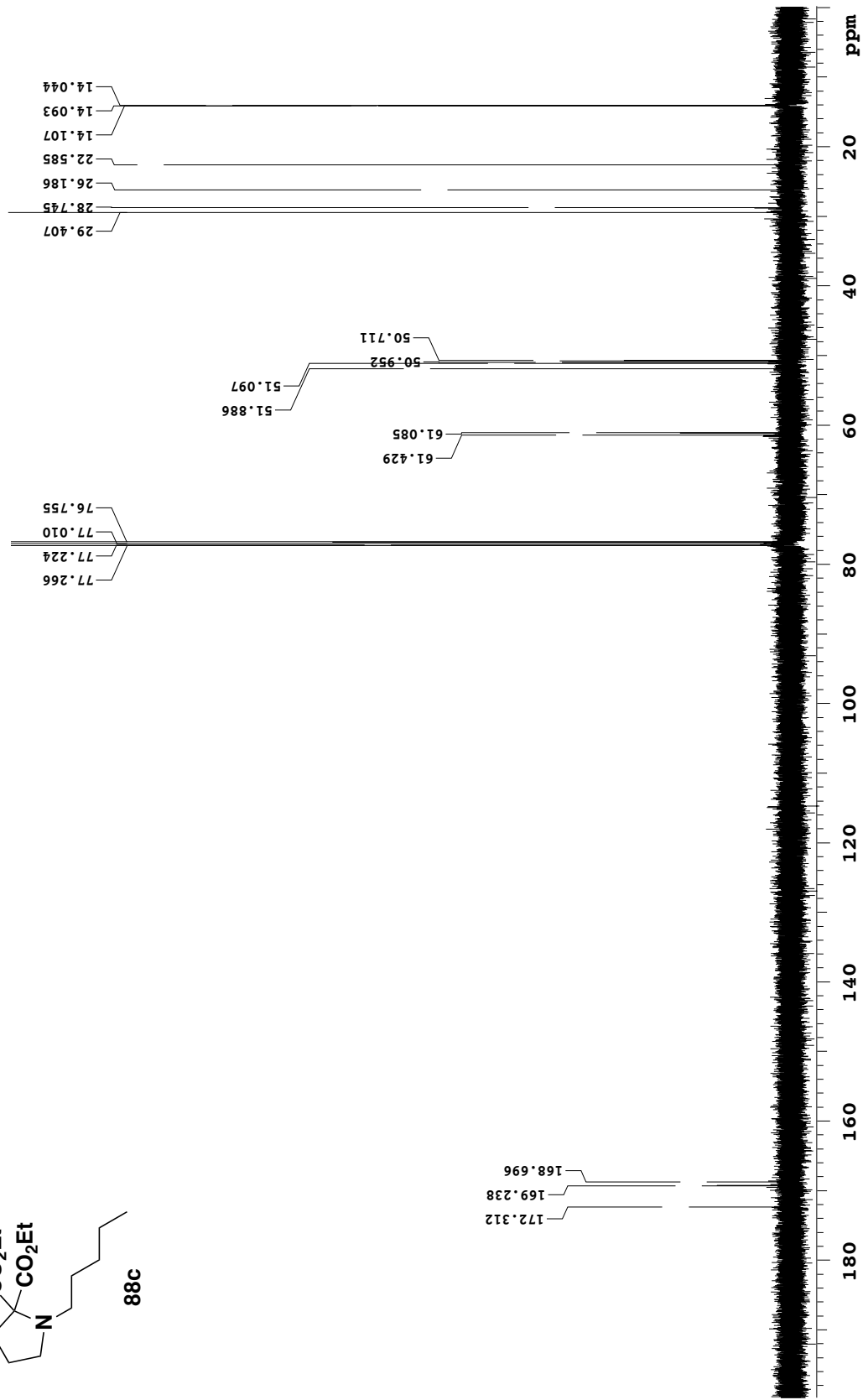
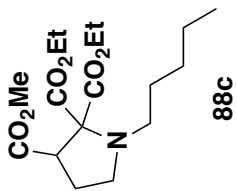

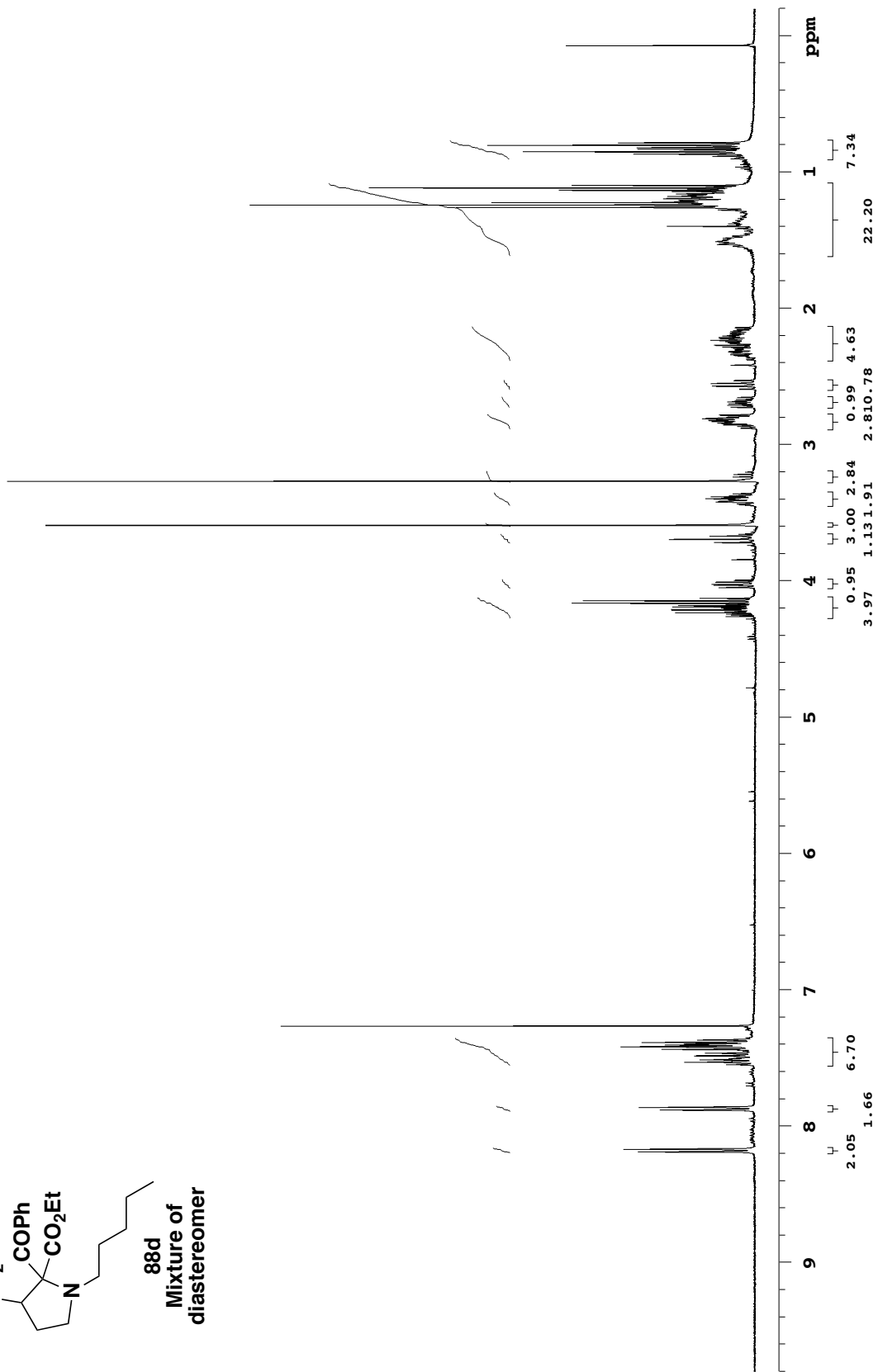
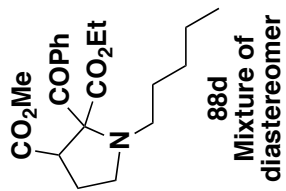

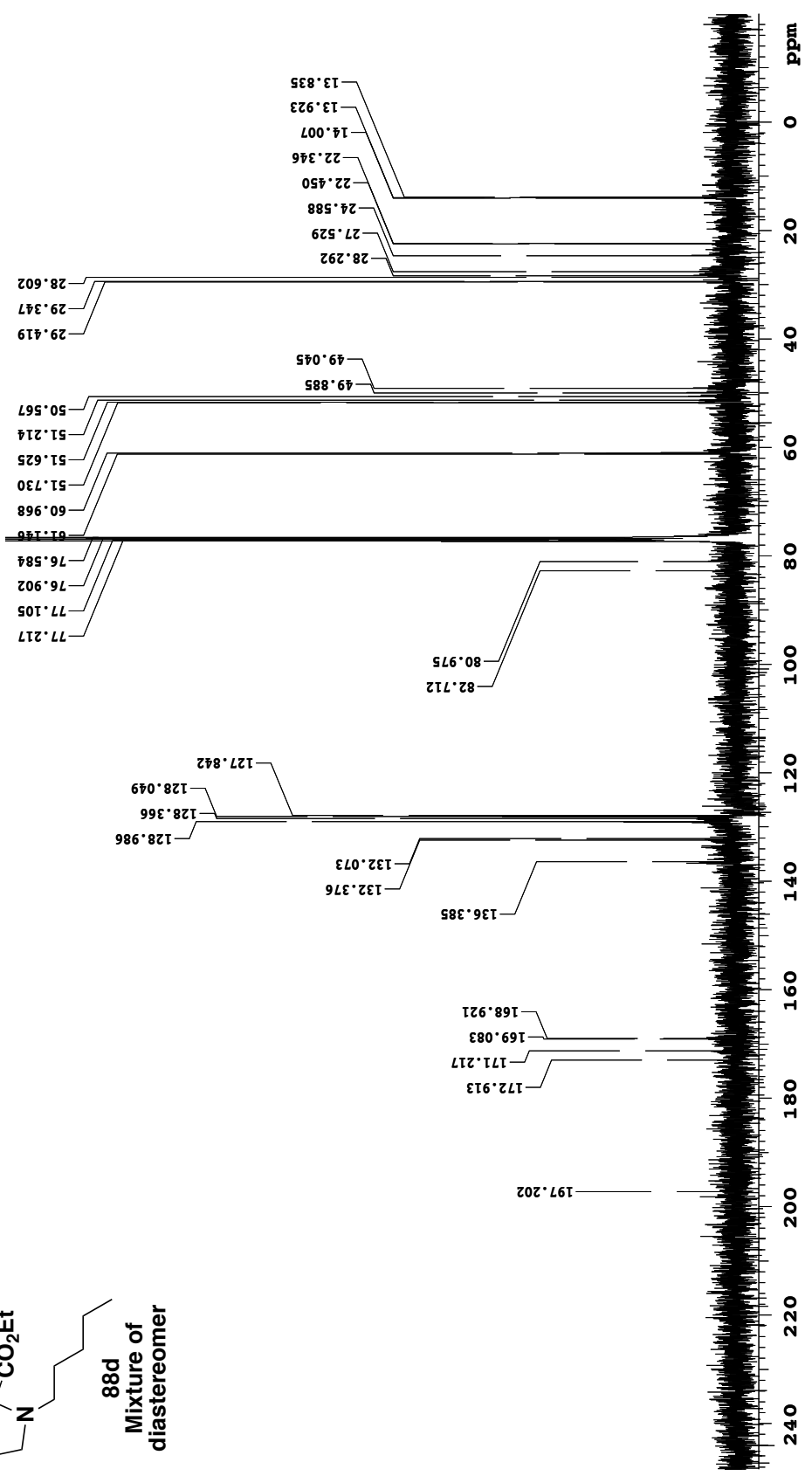
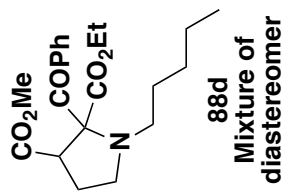

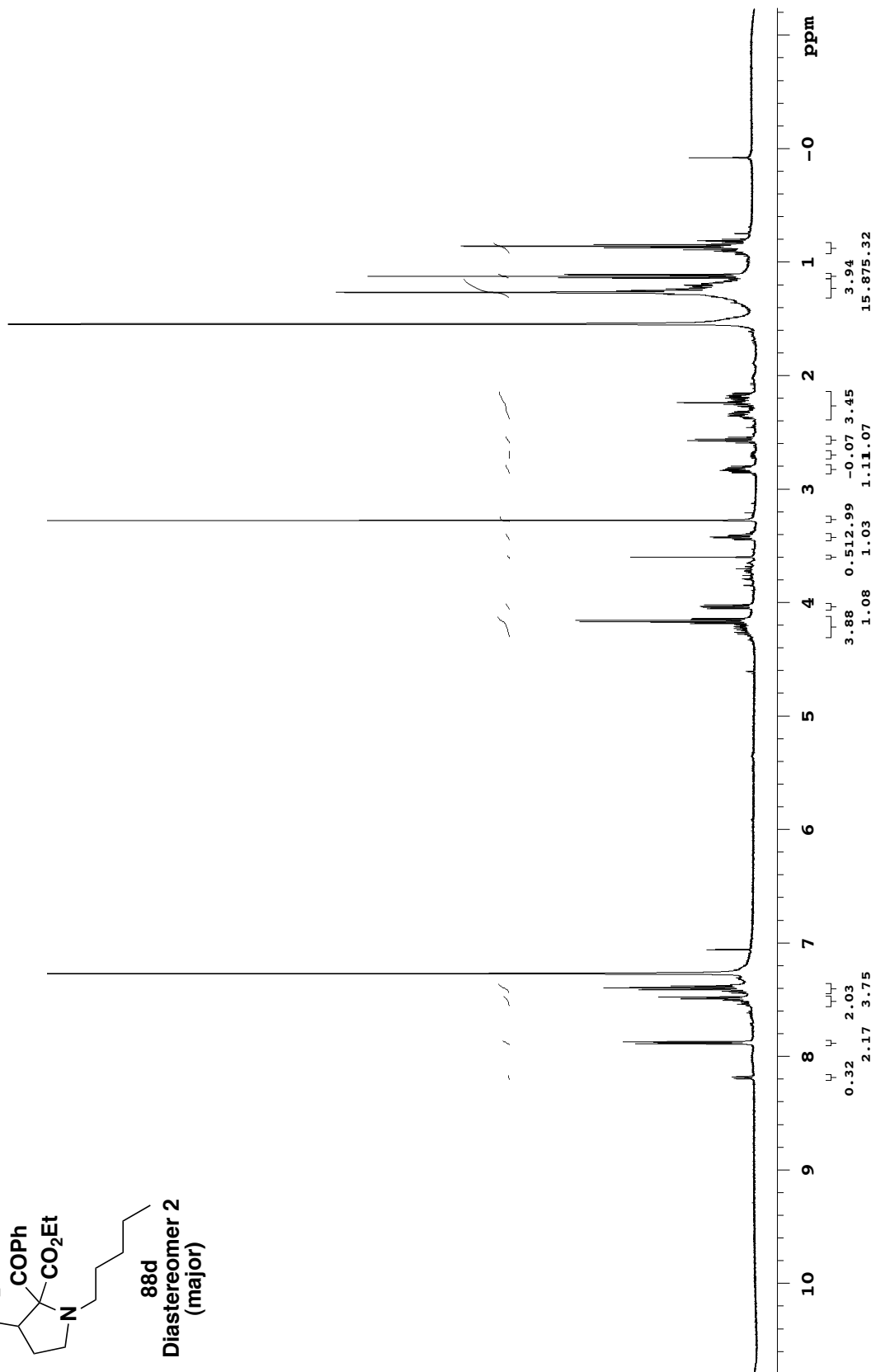
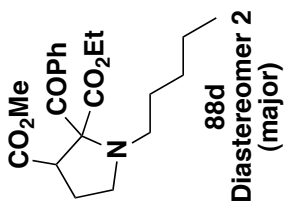

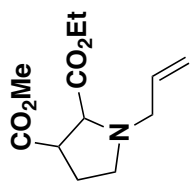

88e
Mixture of
diastereomers

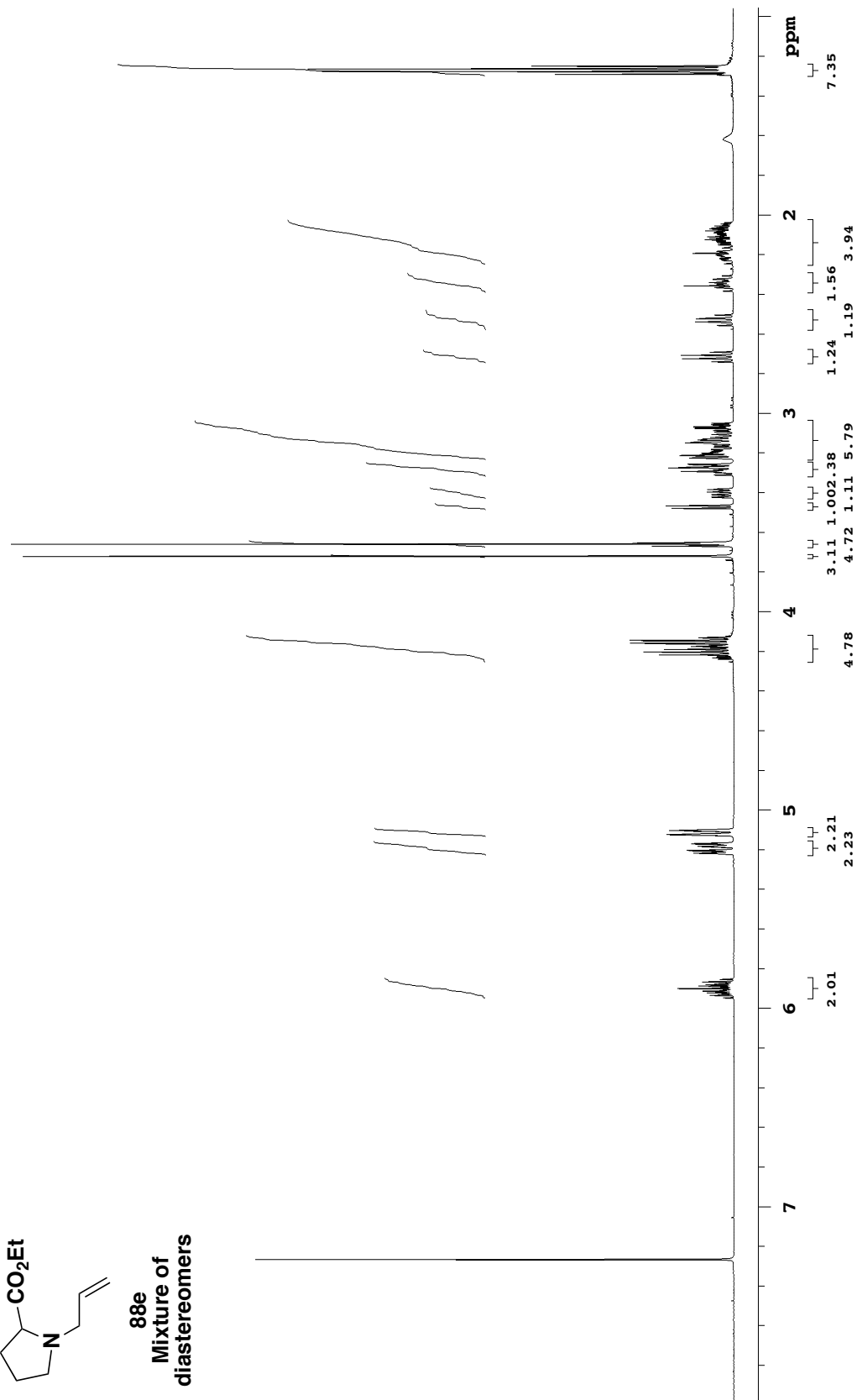

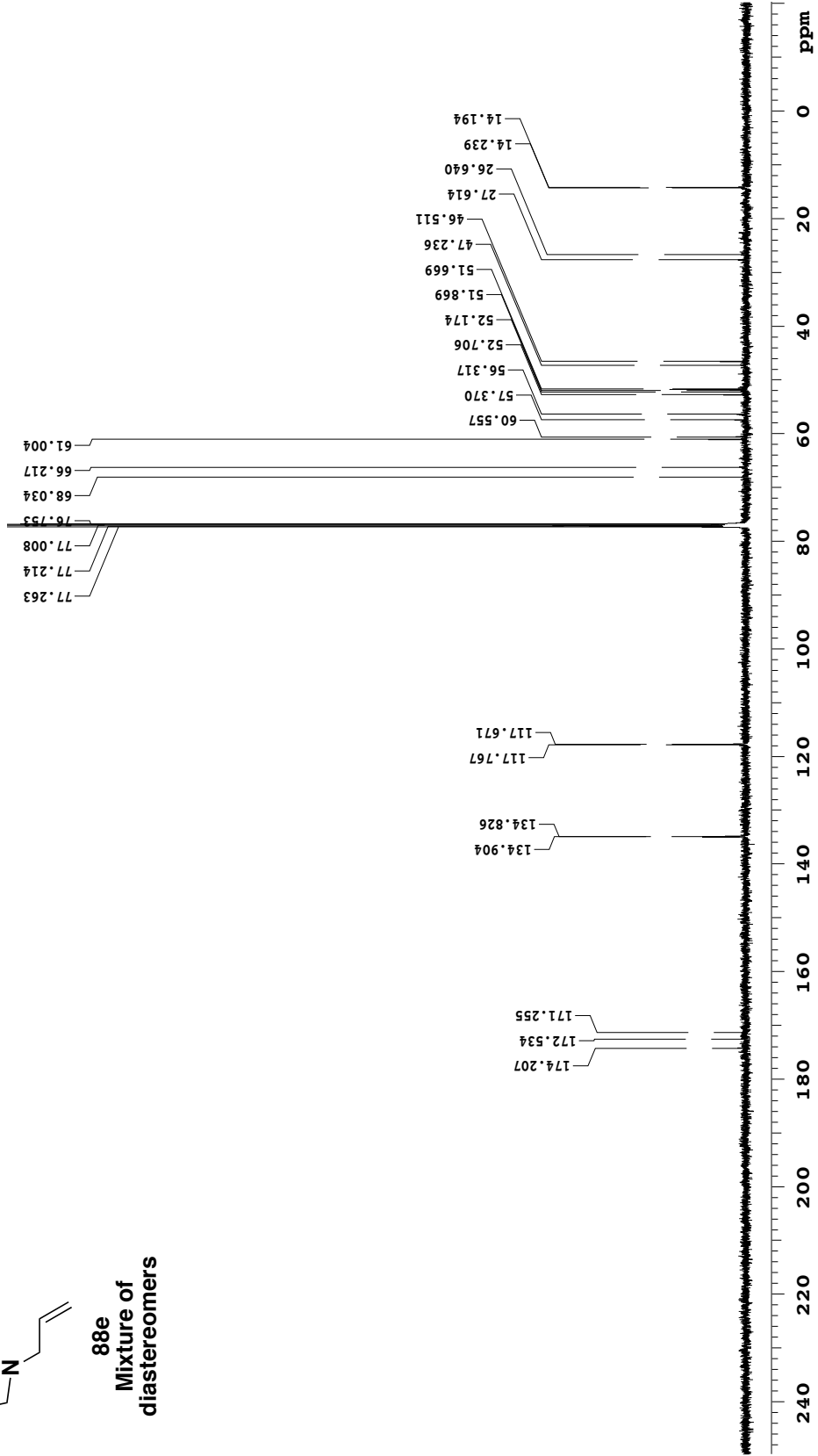
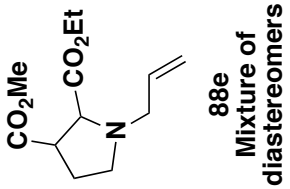

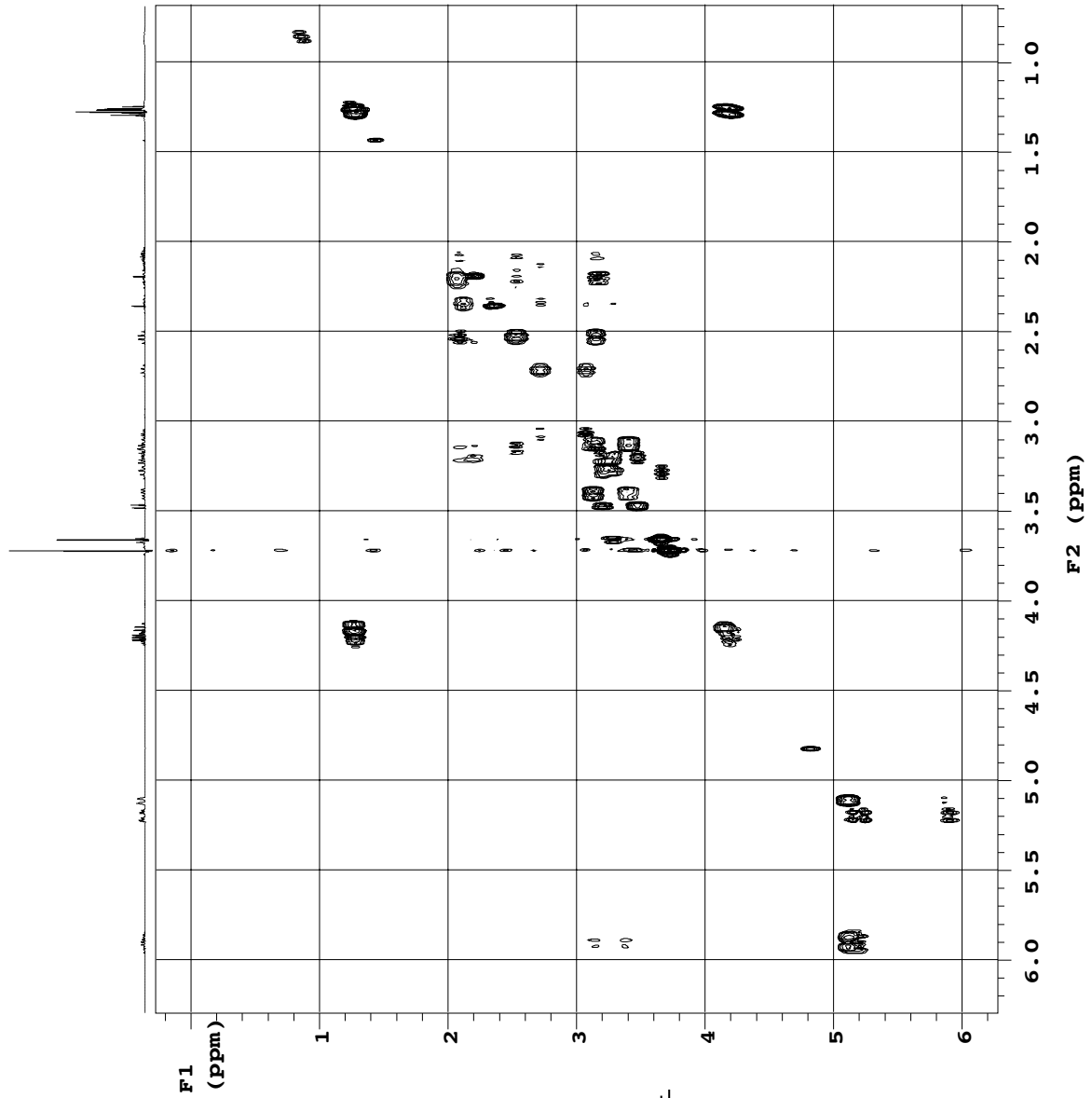
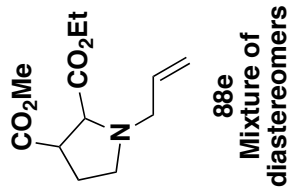

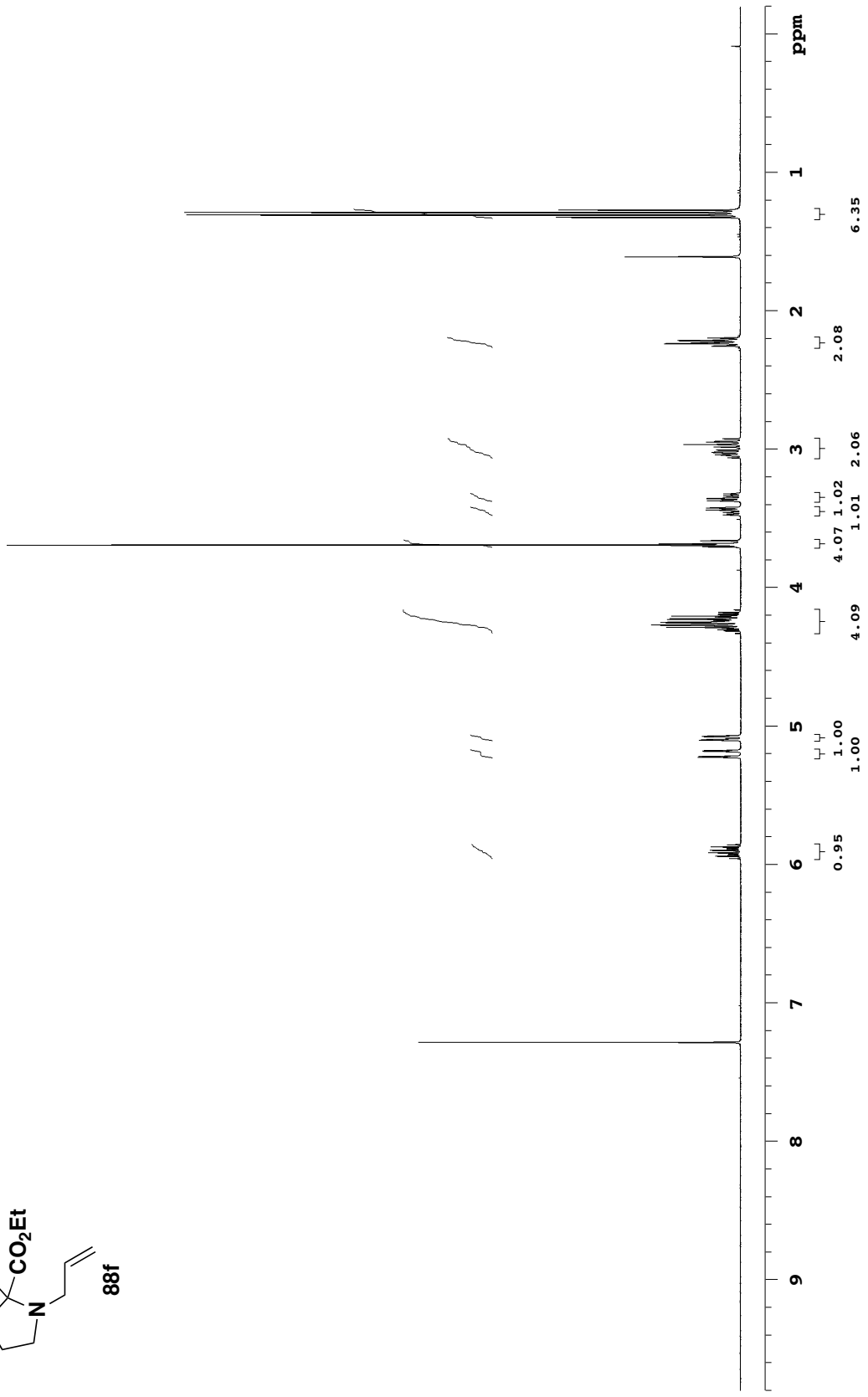
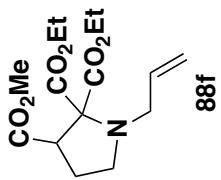

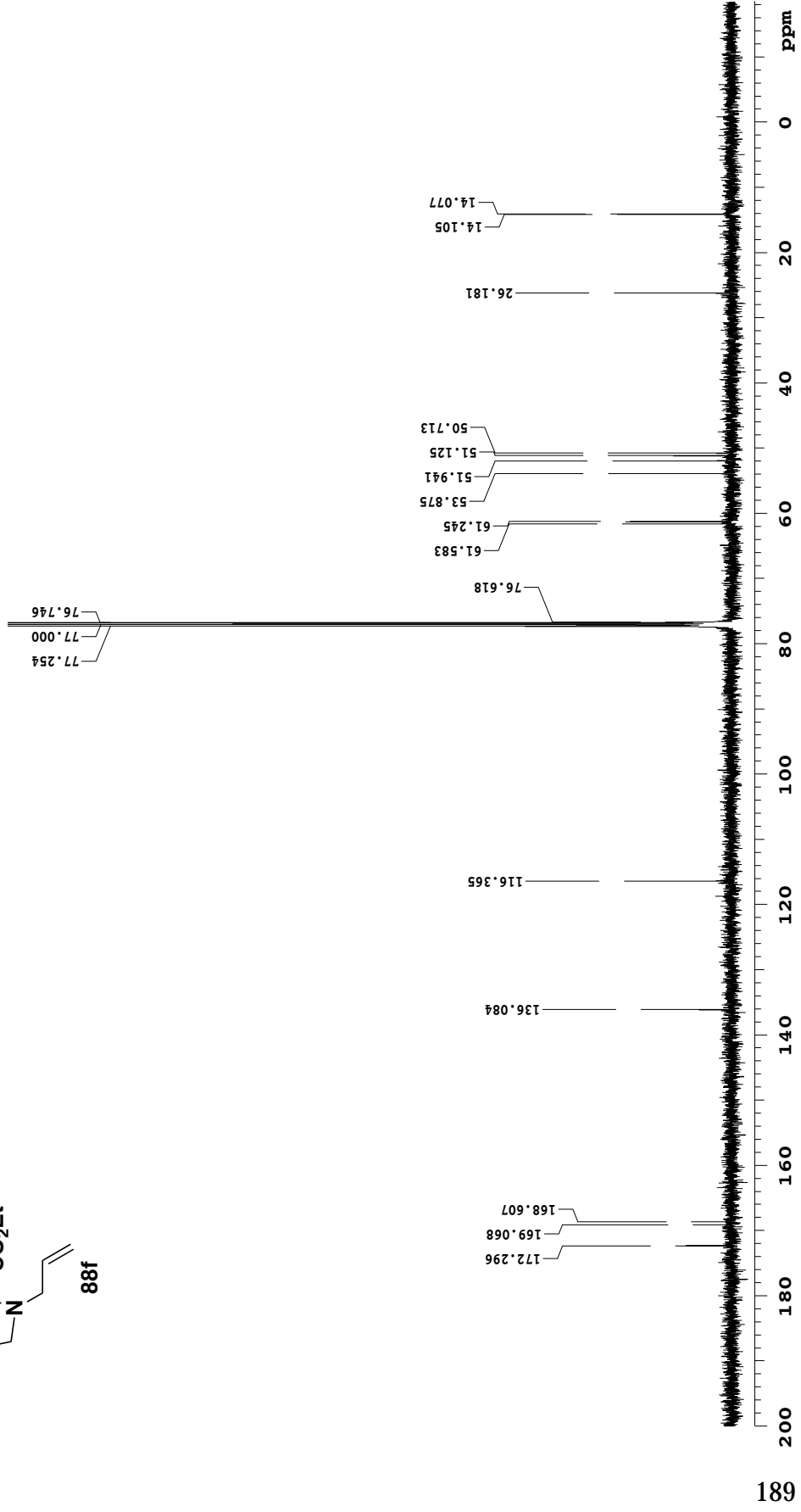
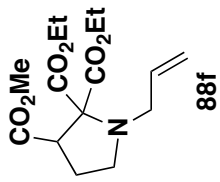

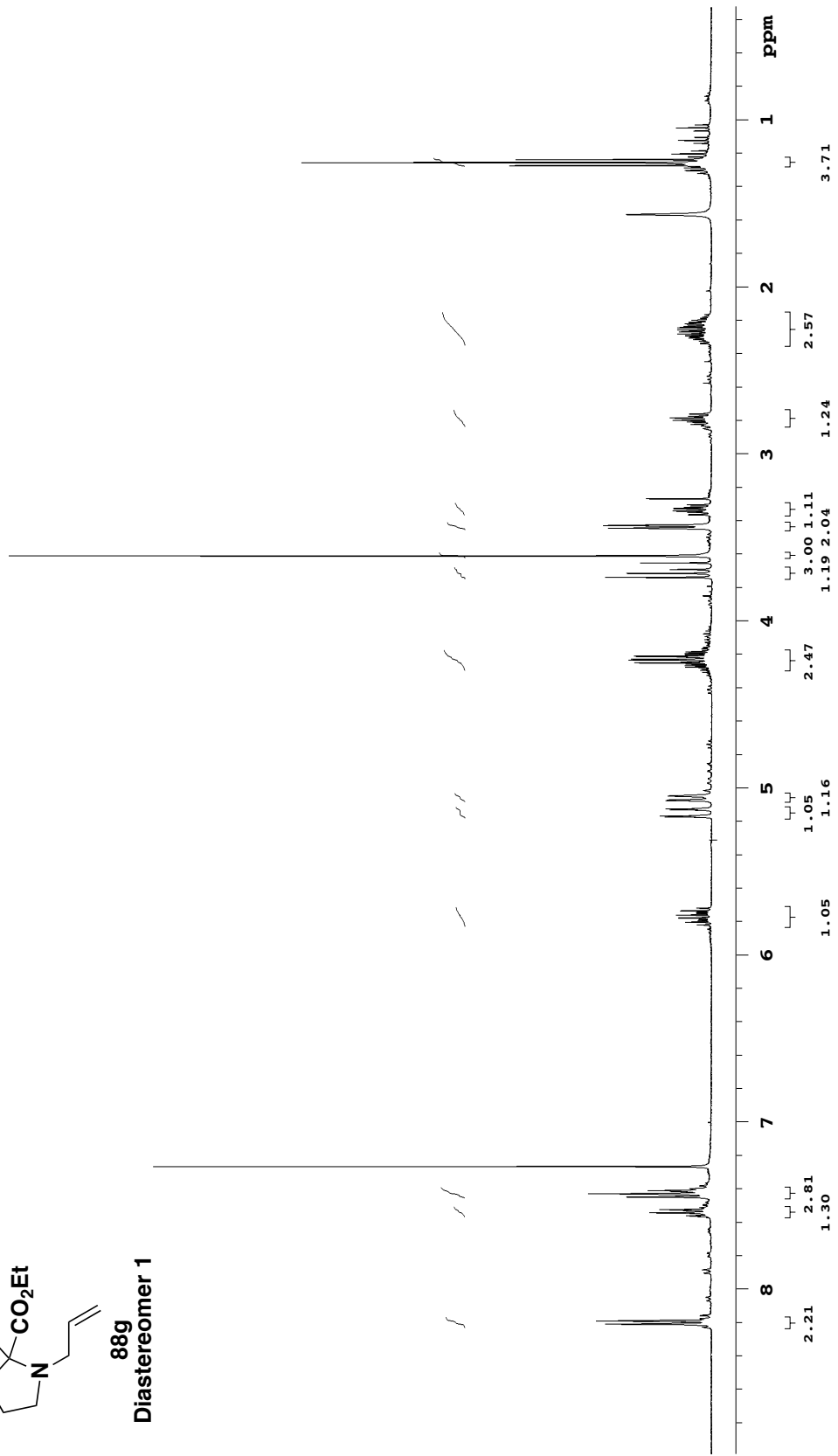
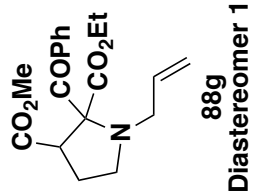

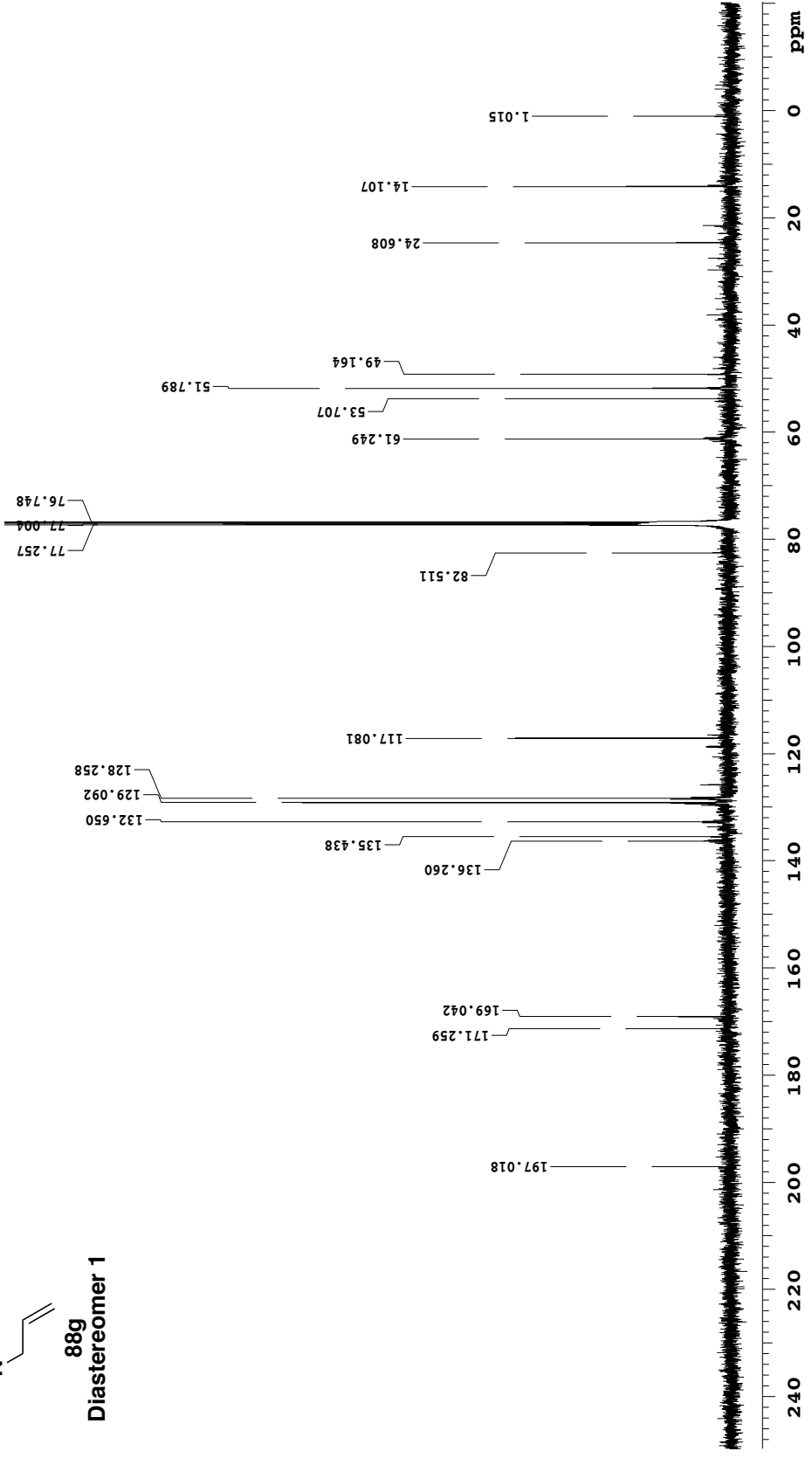
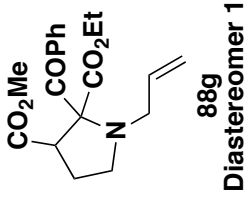

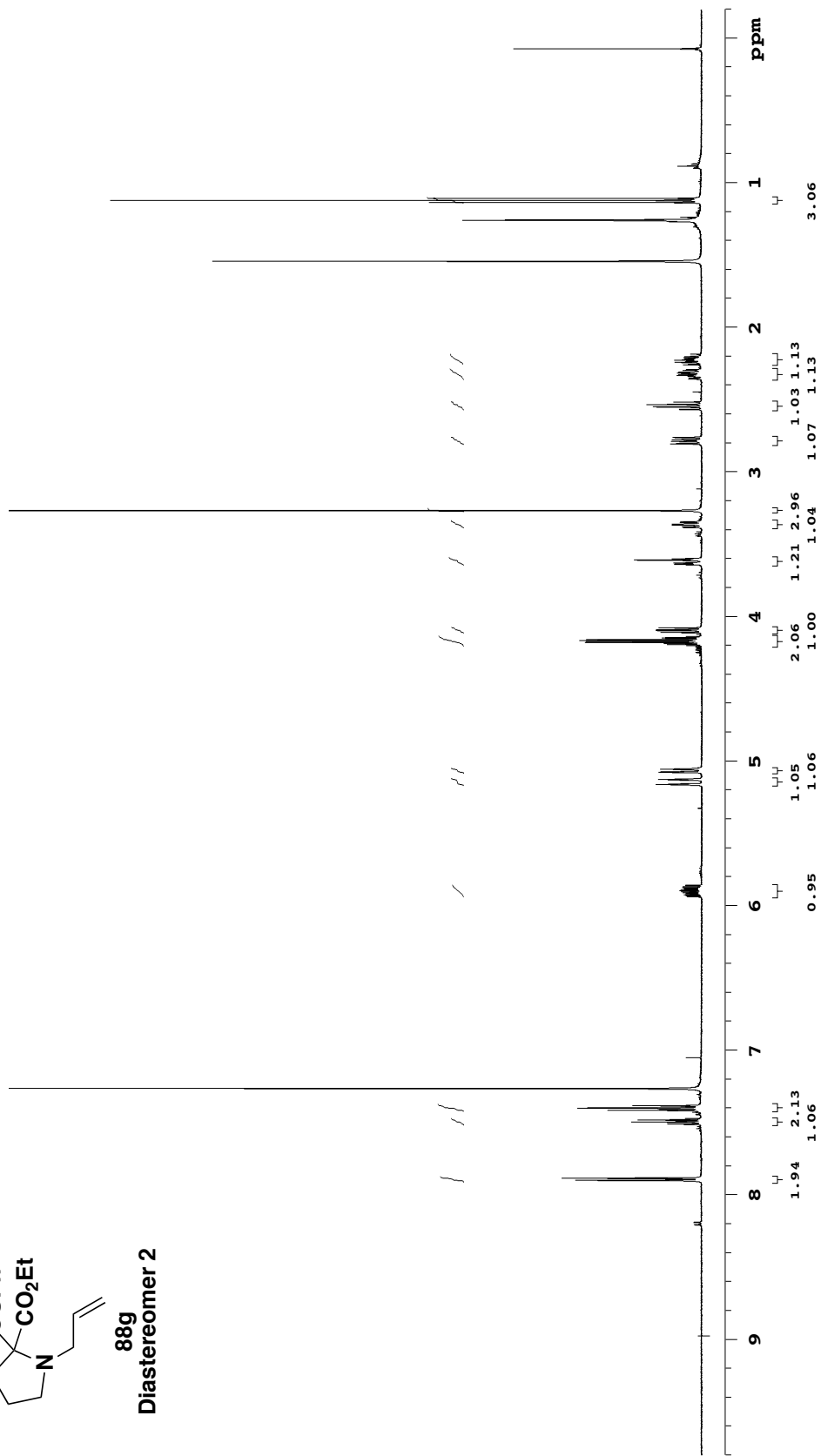
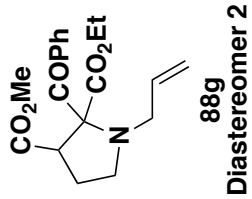

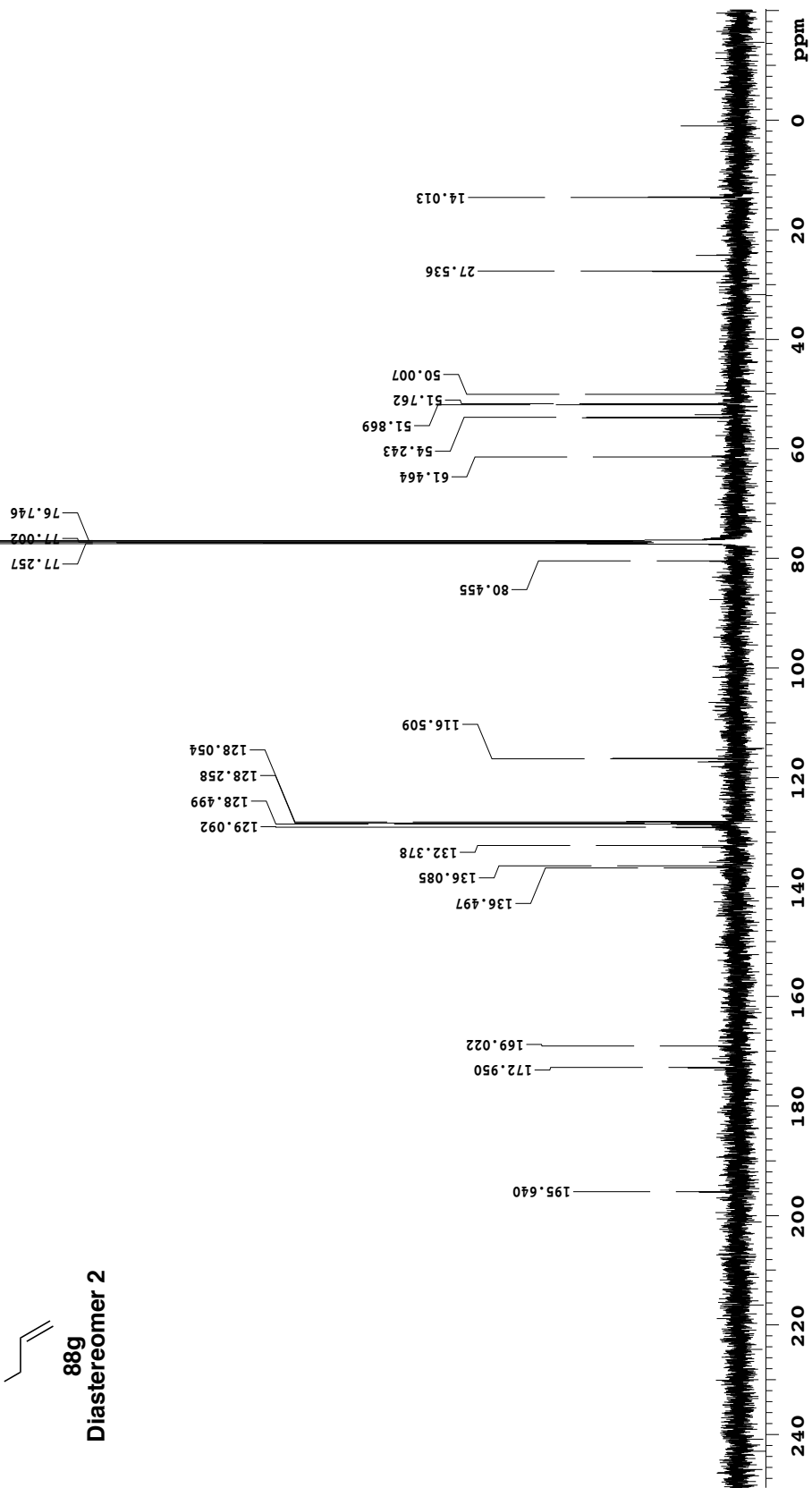
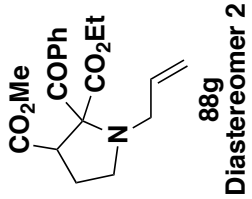

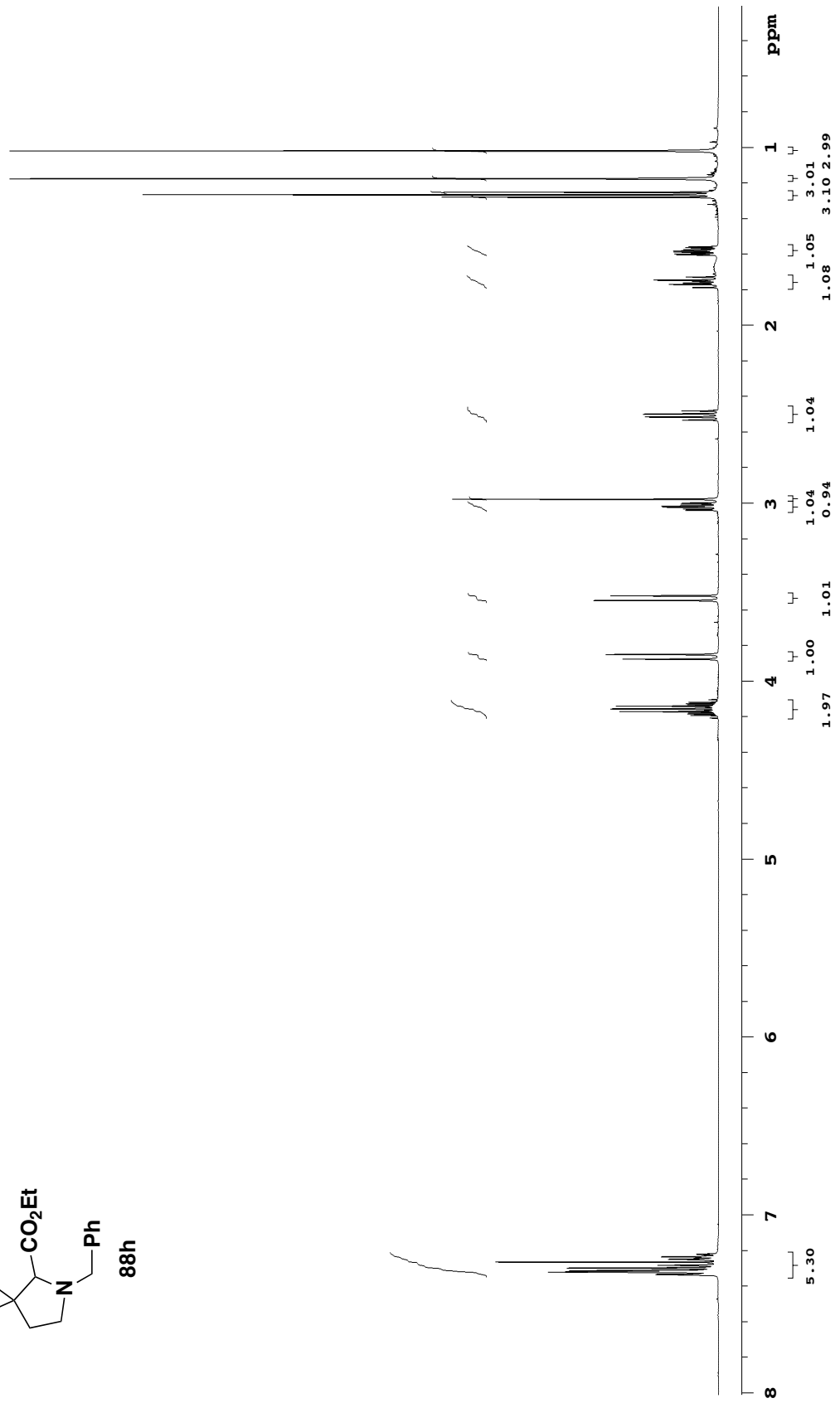
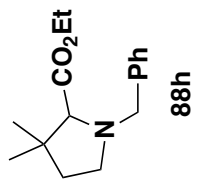

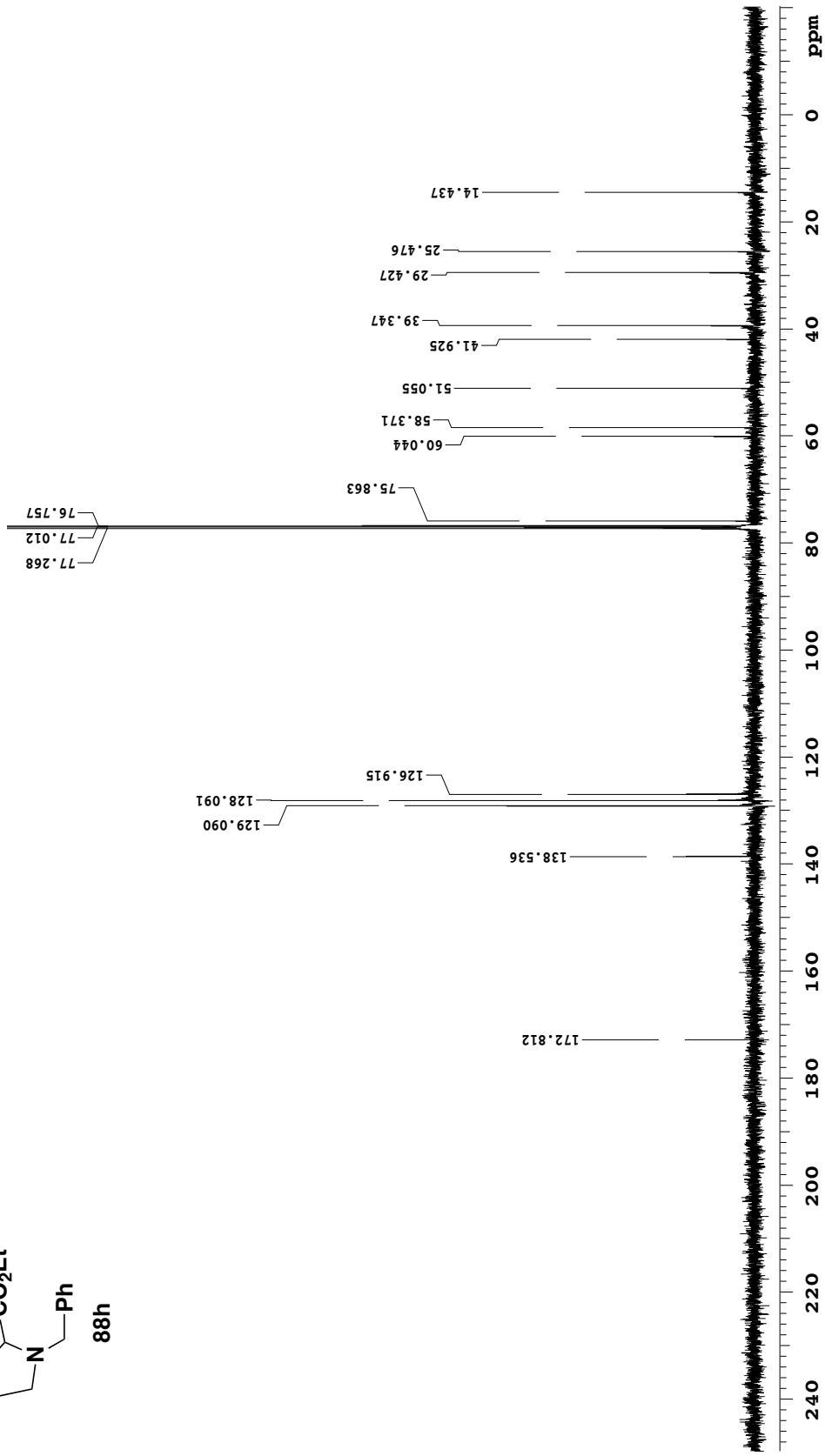
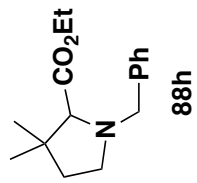

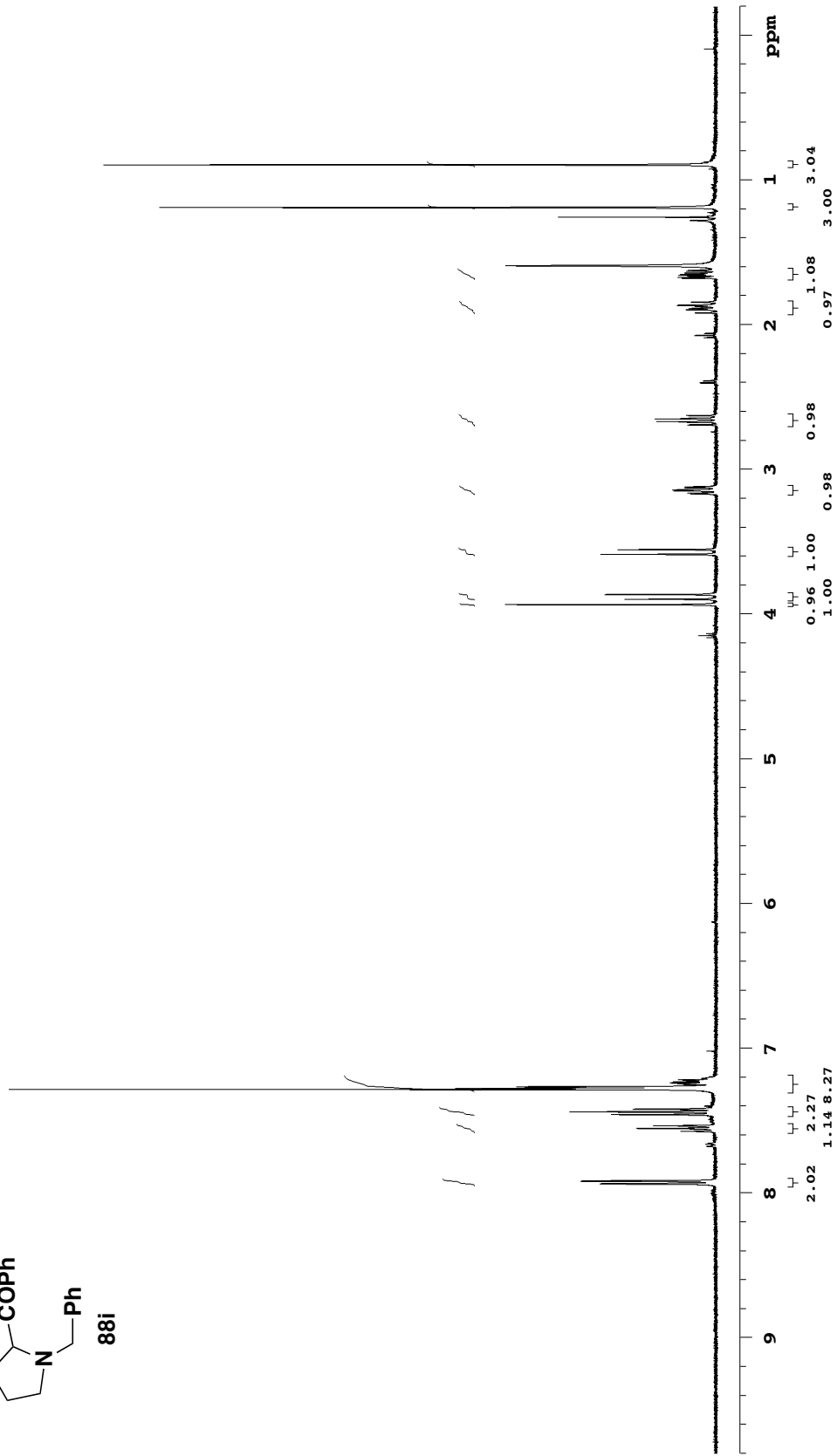
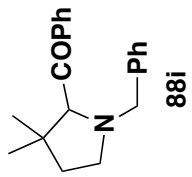

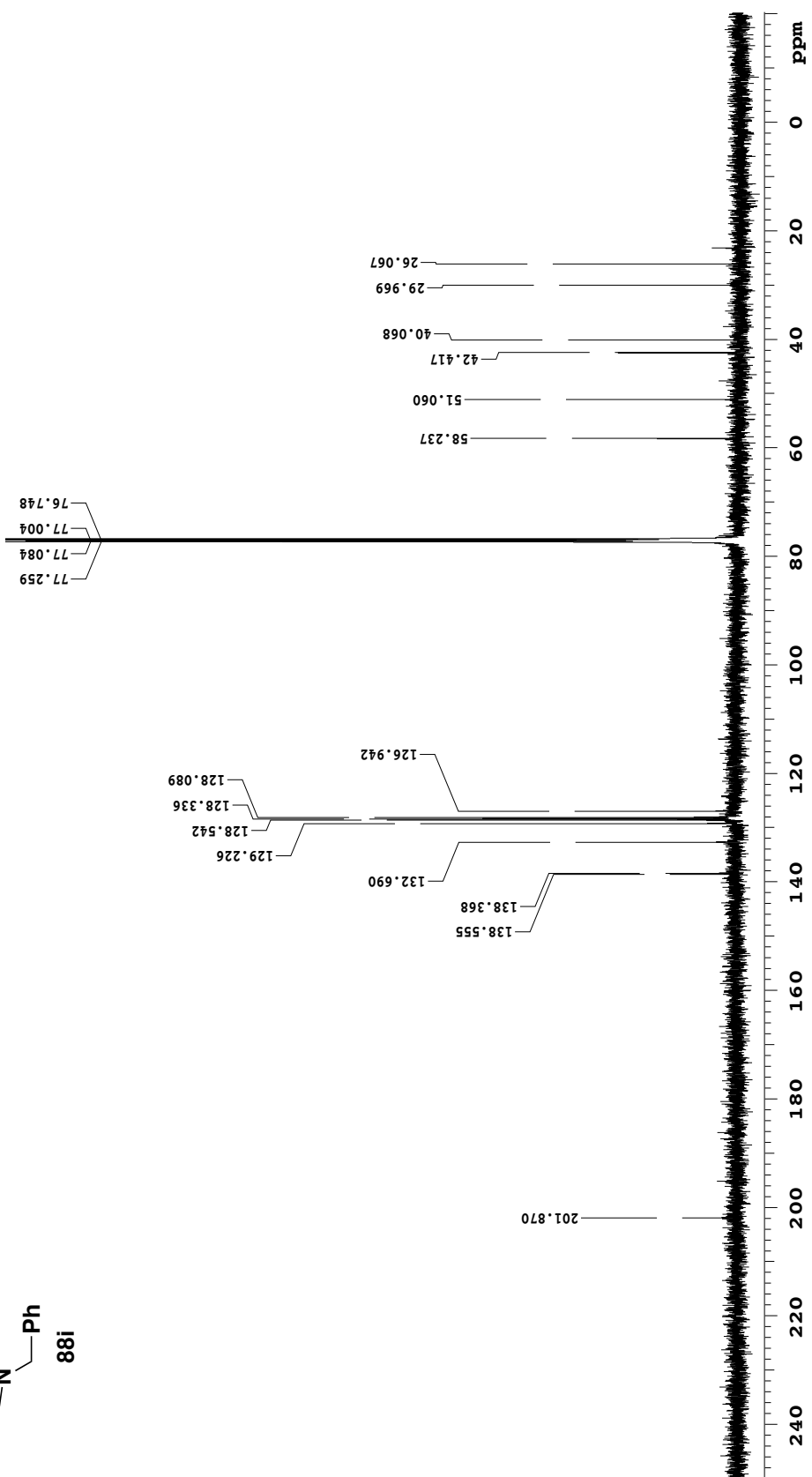
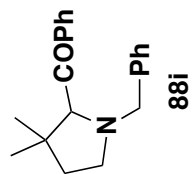

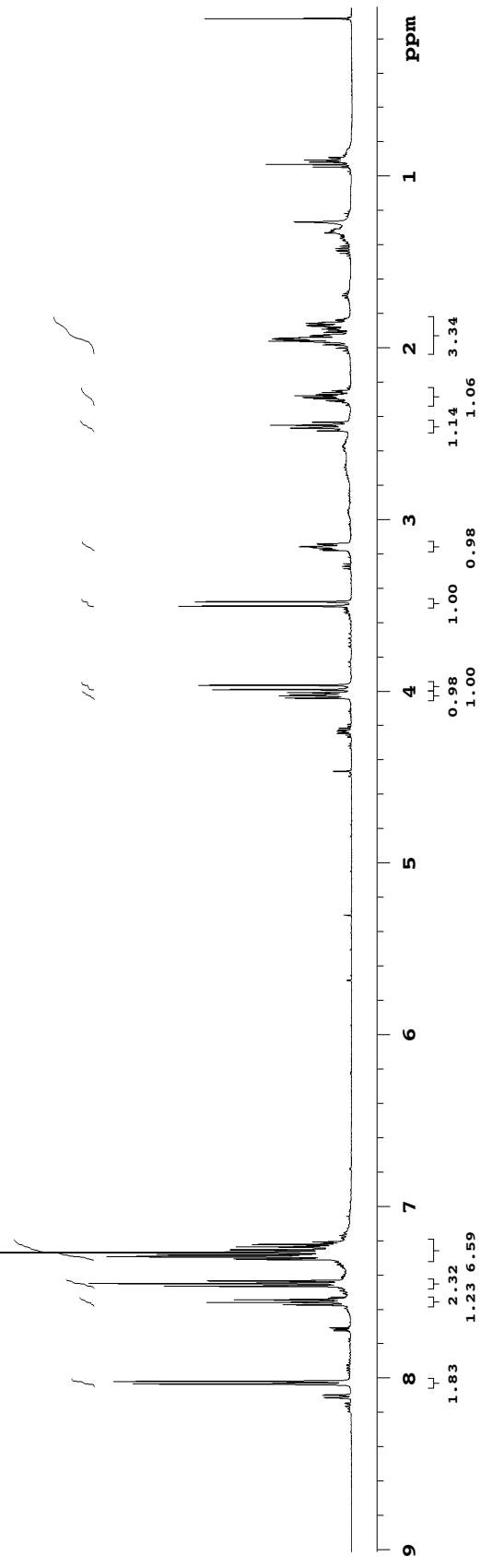
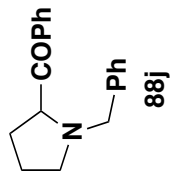

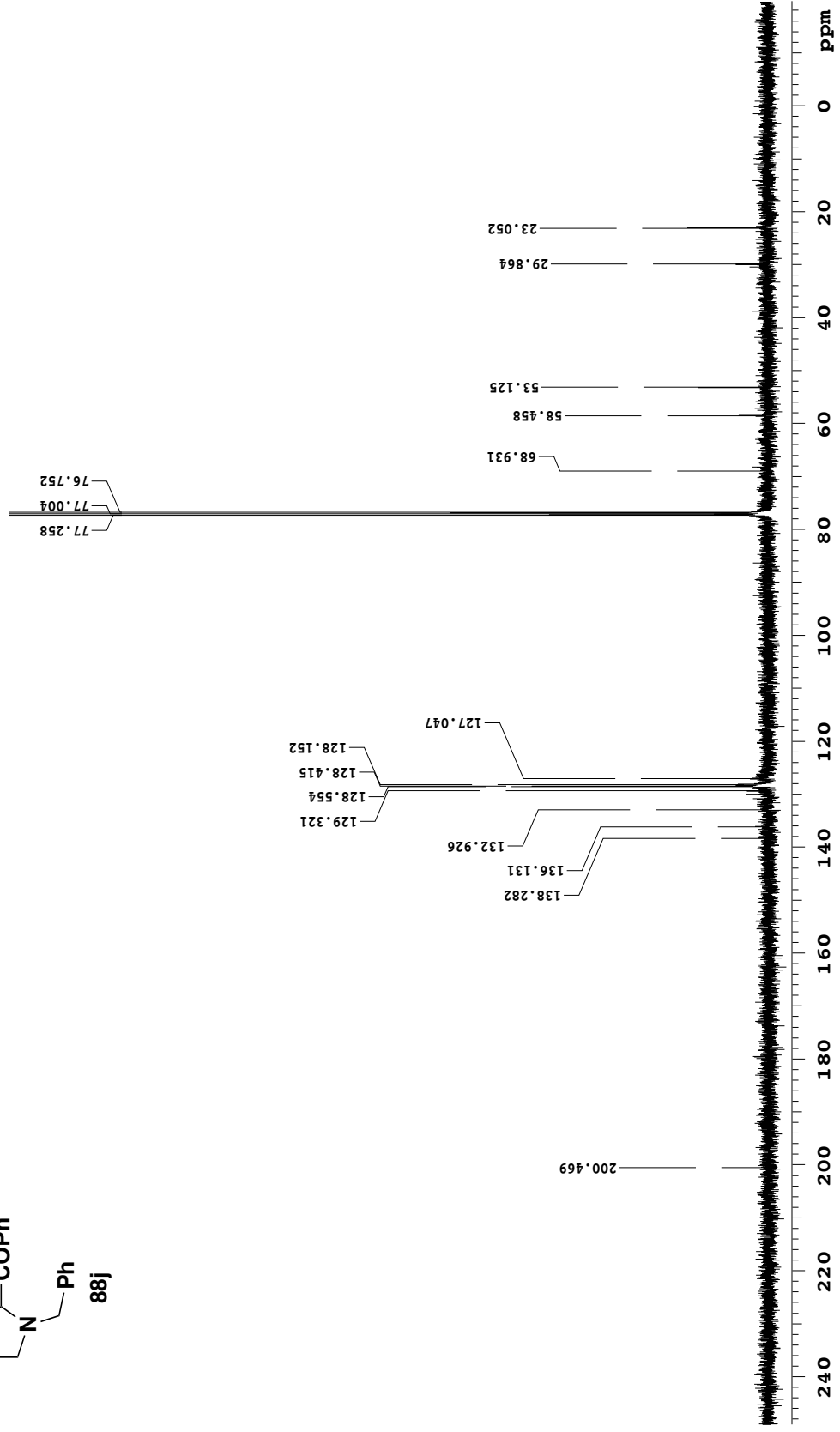
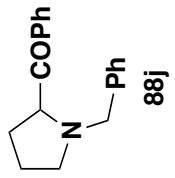

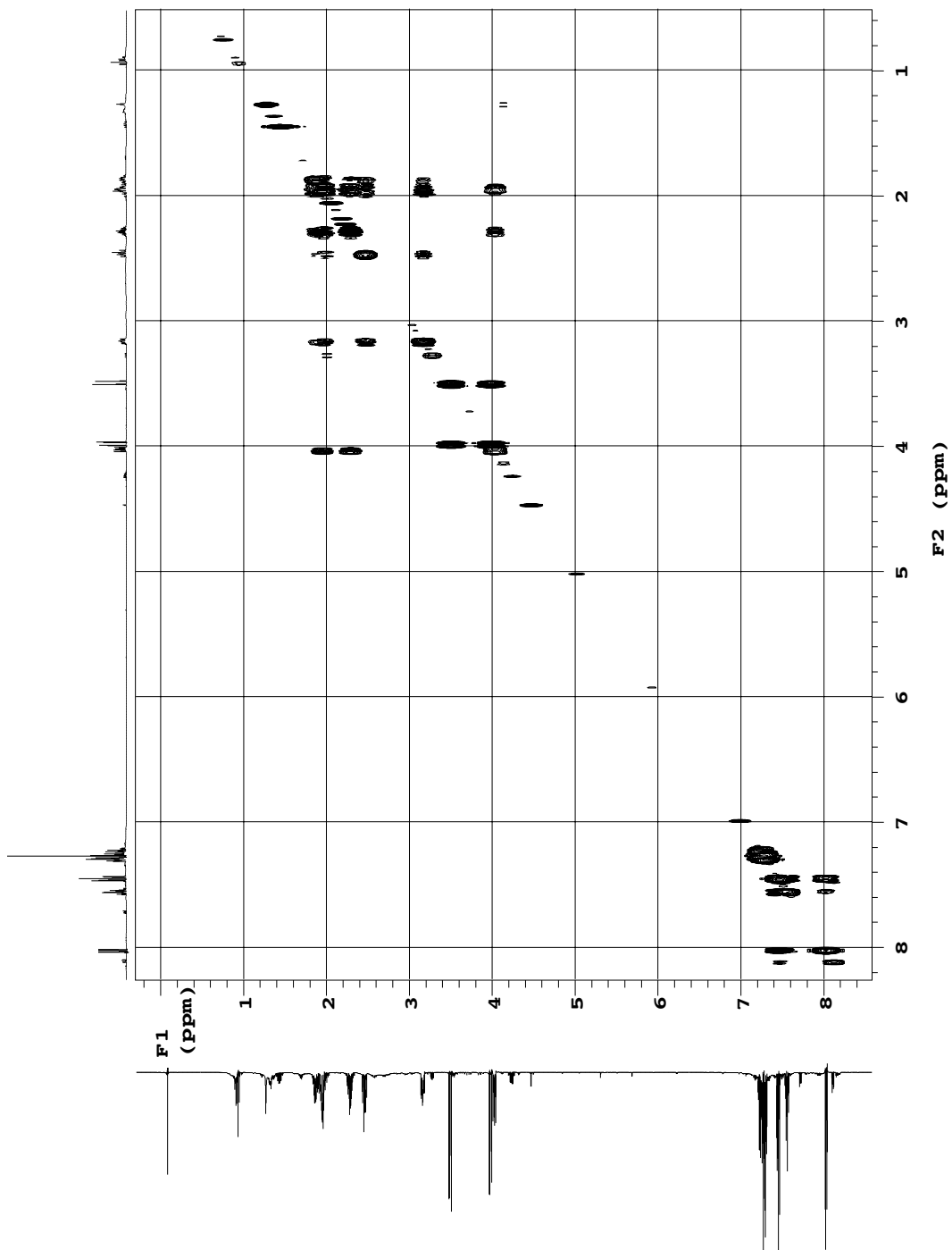
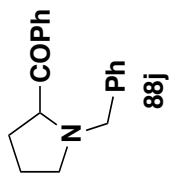

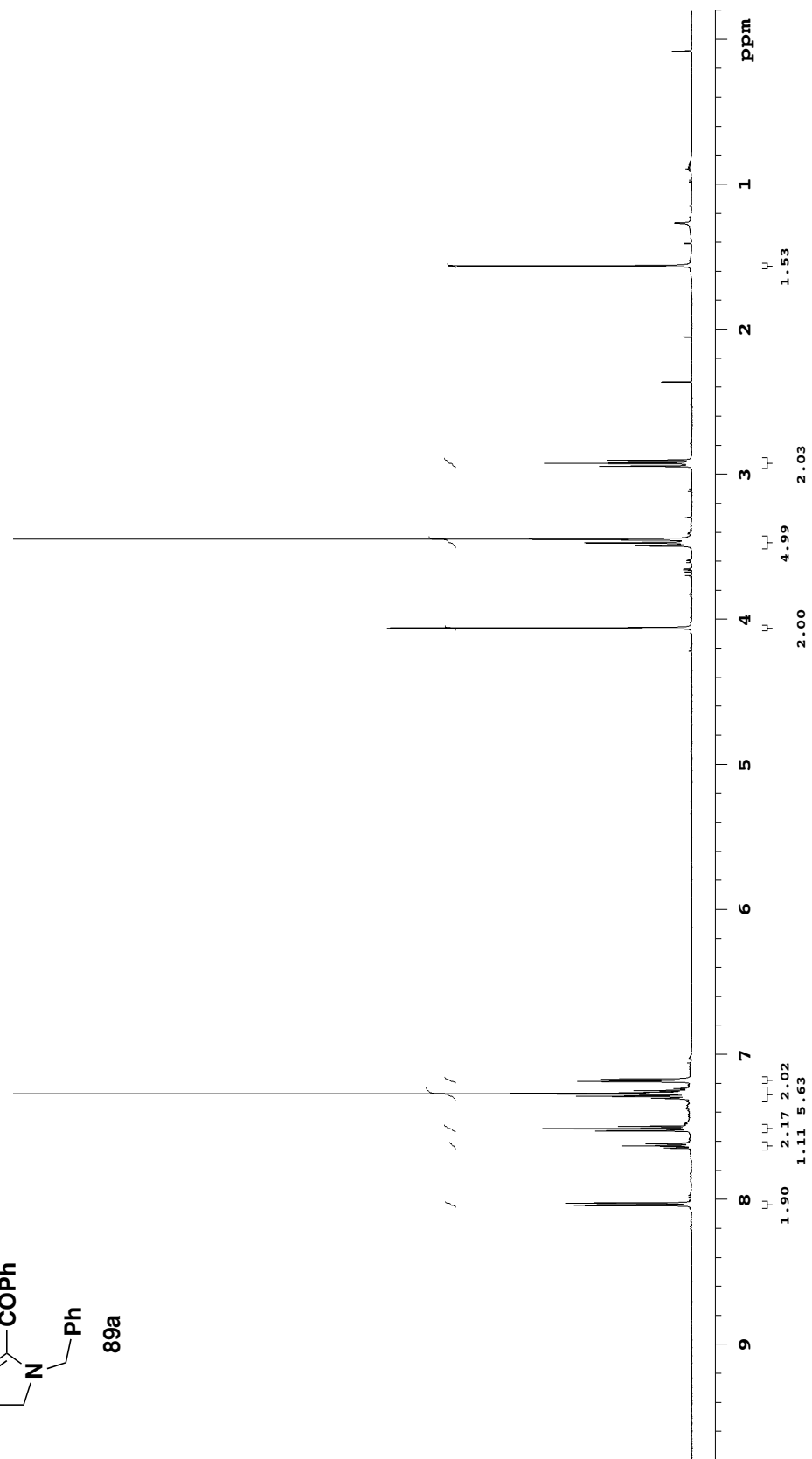
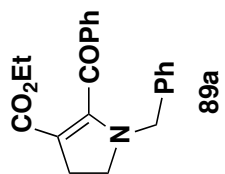

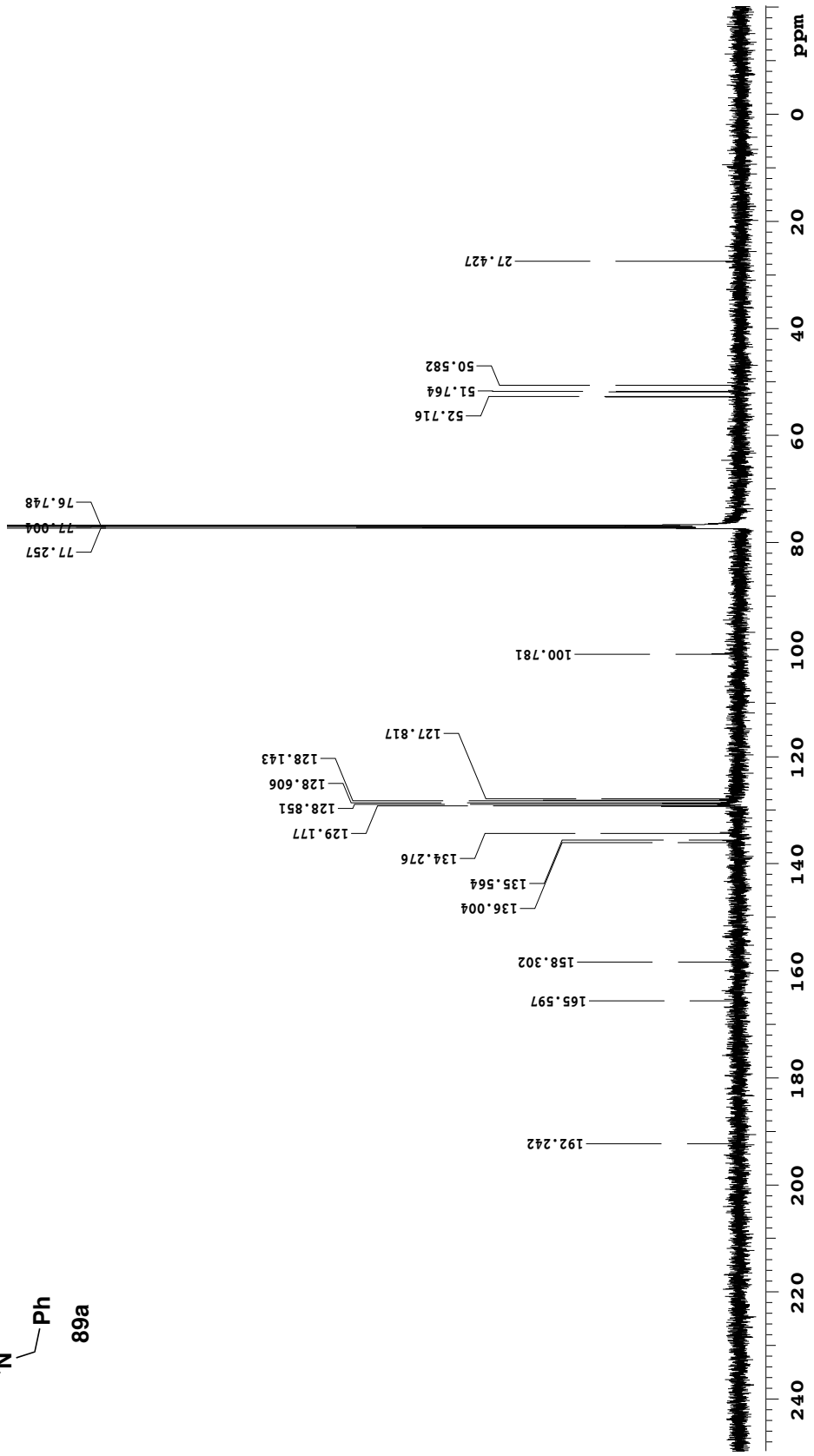
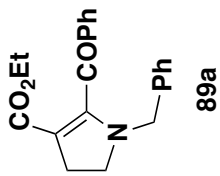

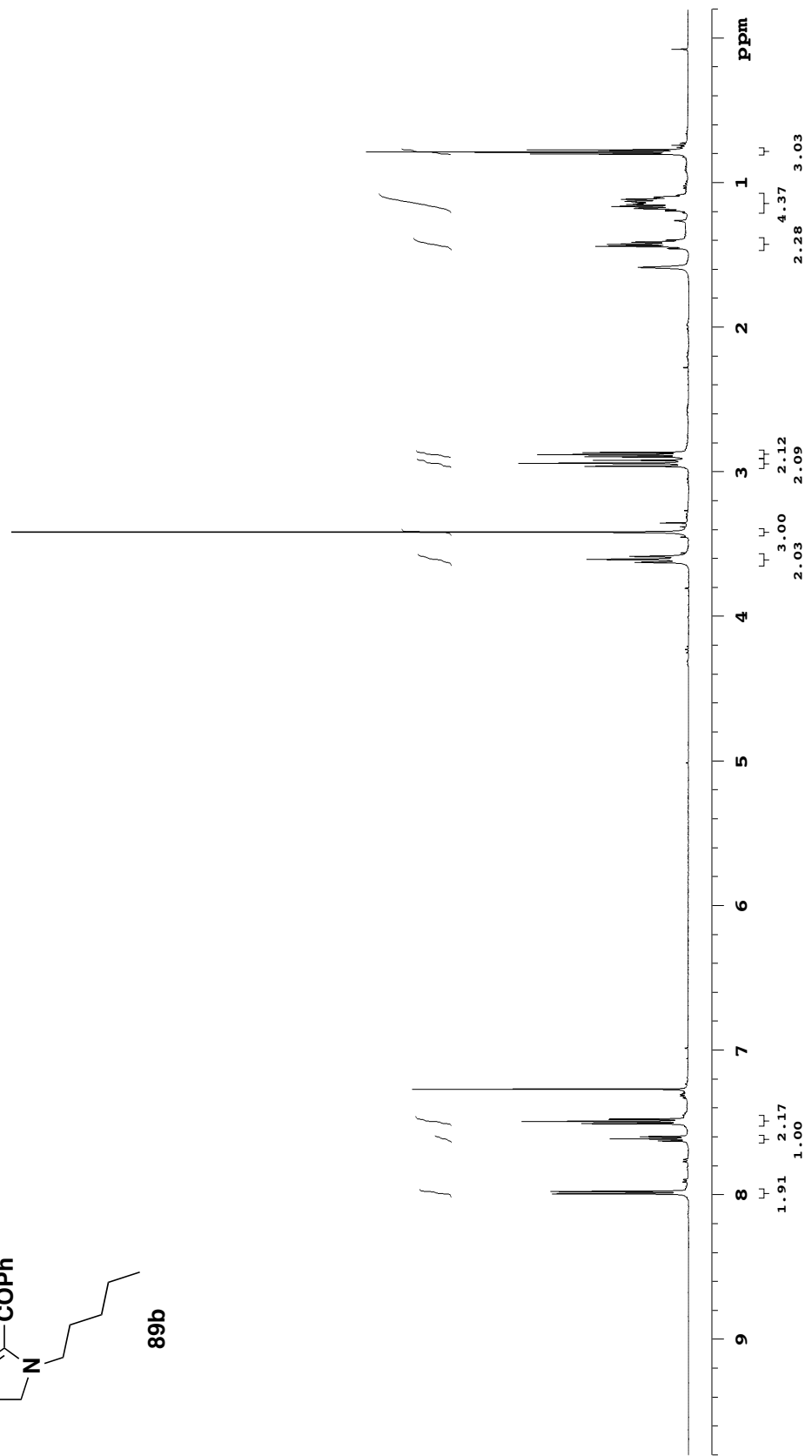
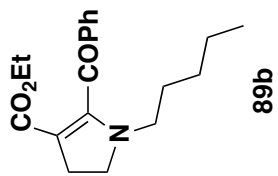

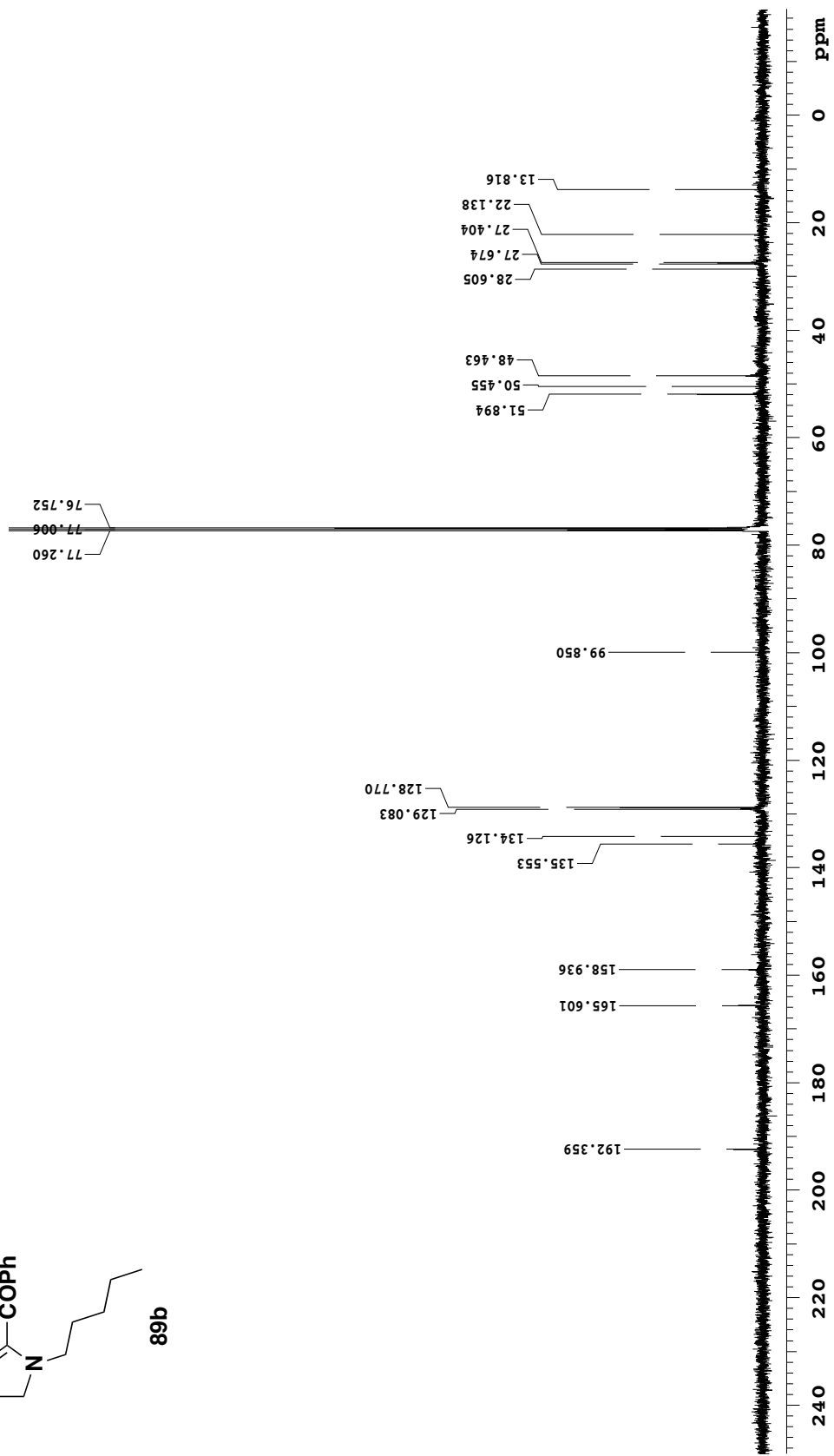
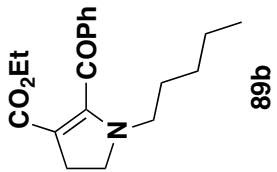

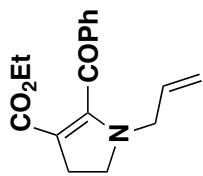

89c

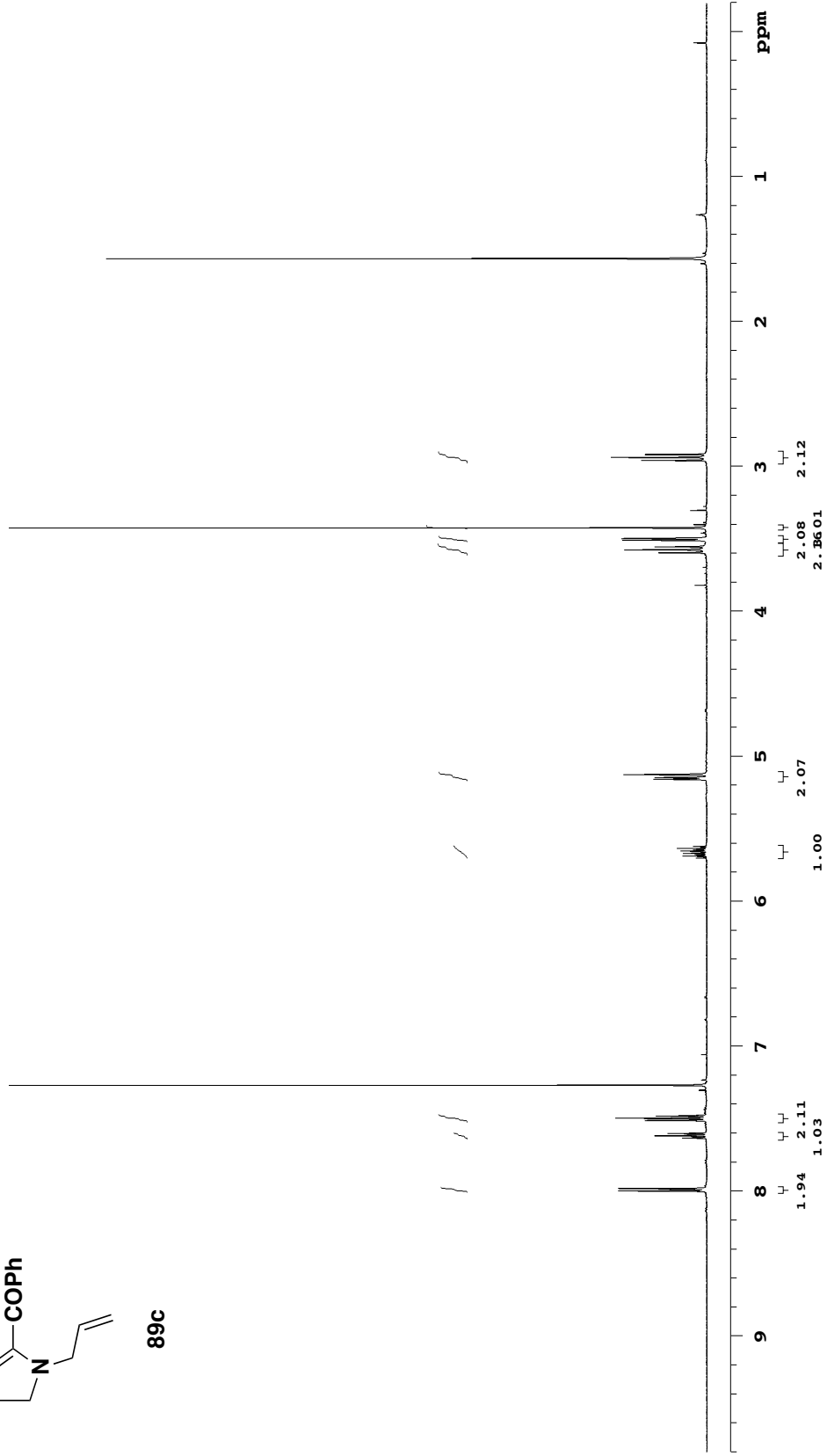

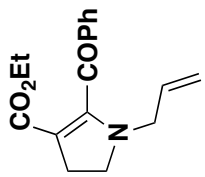

89c

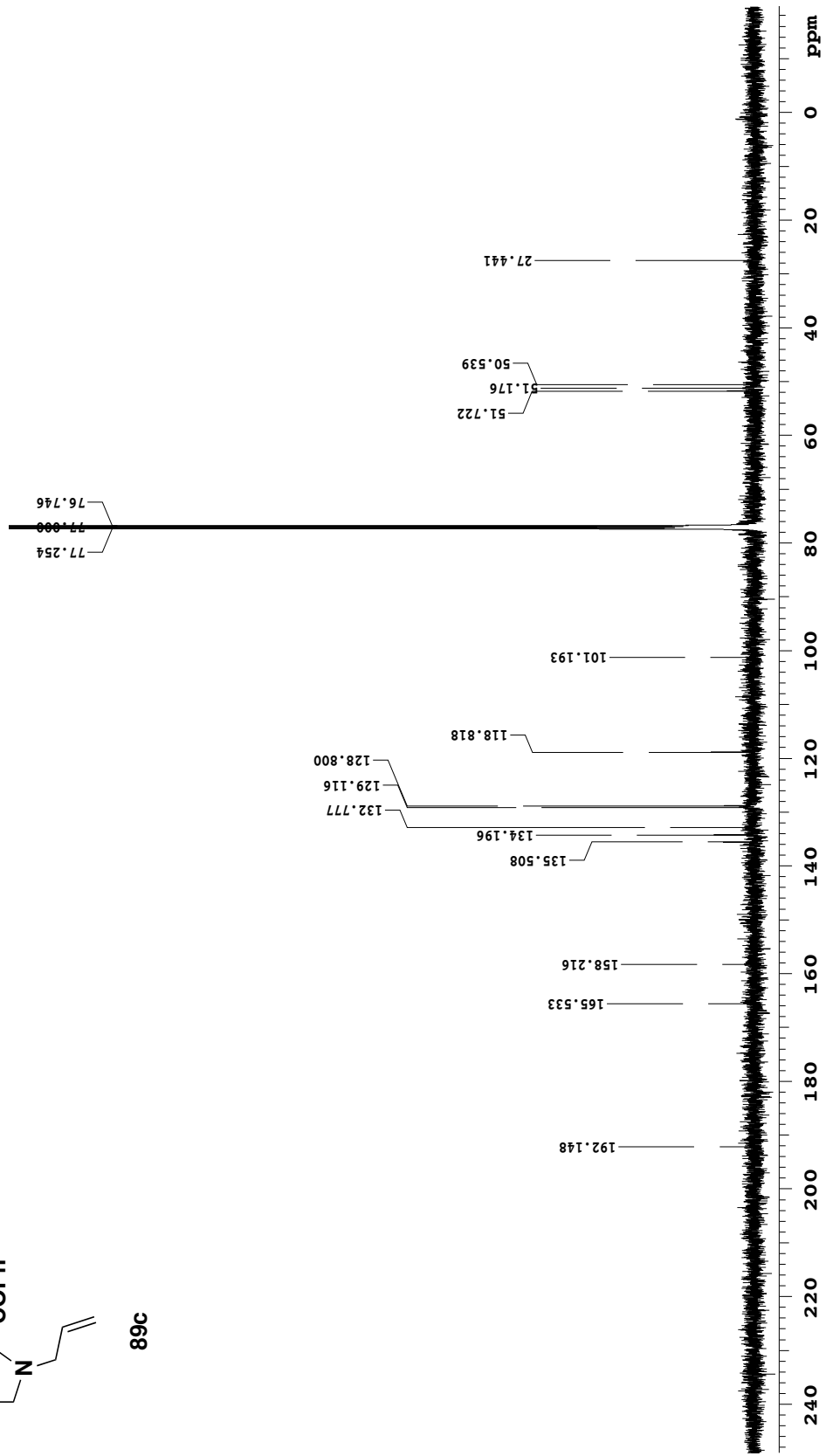

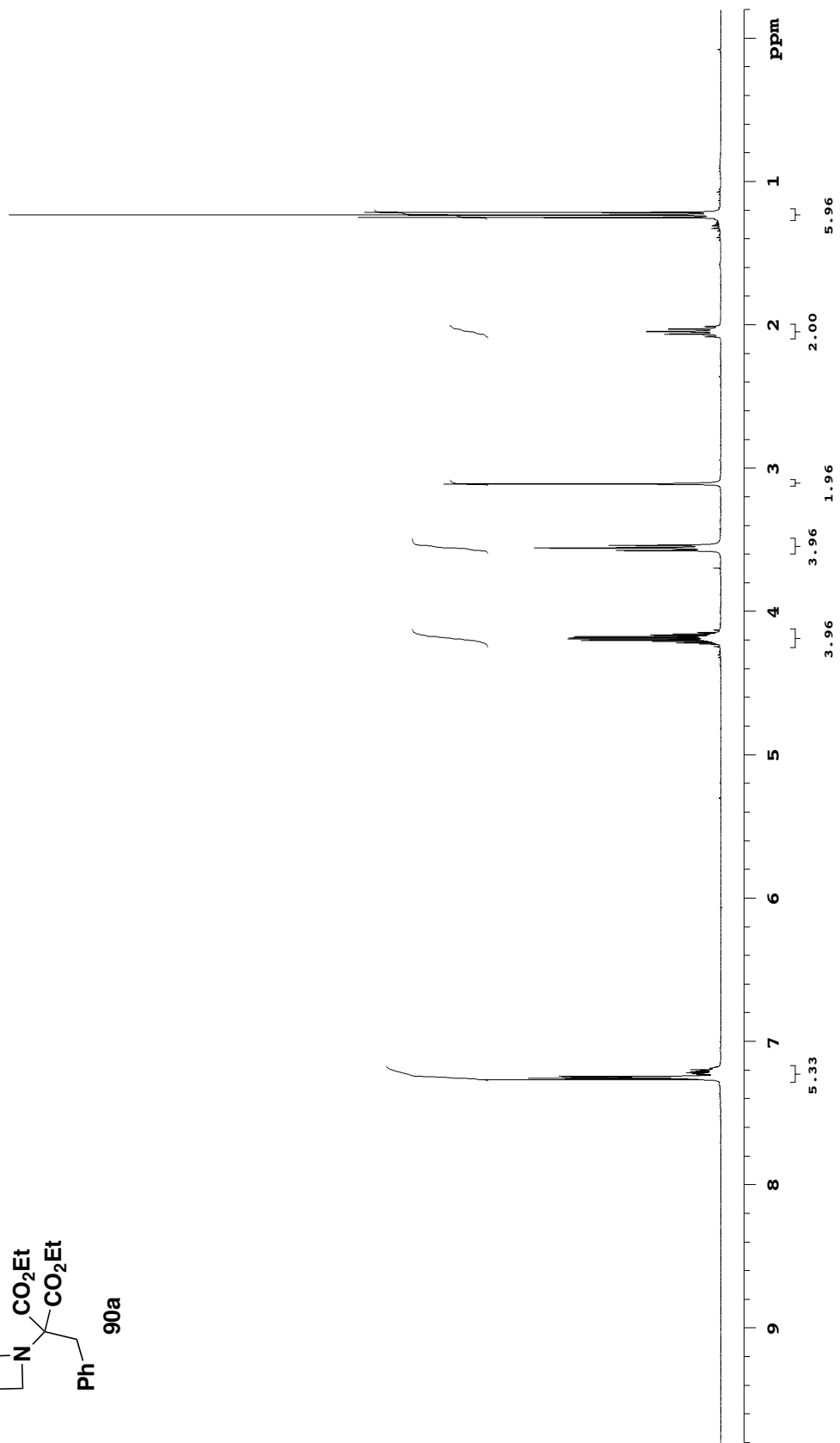
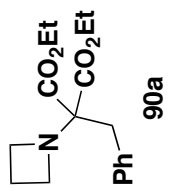

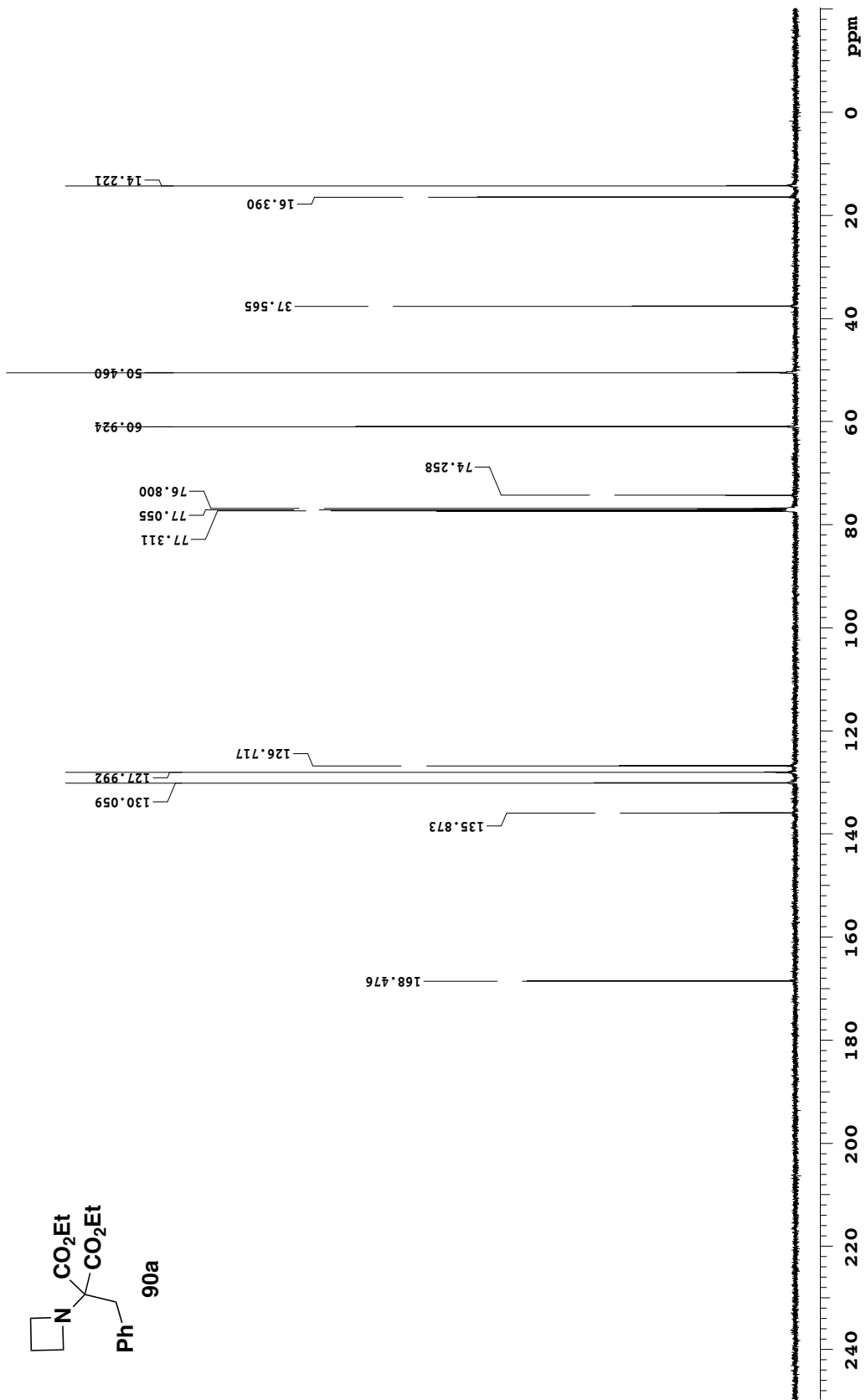

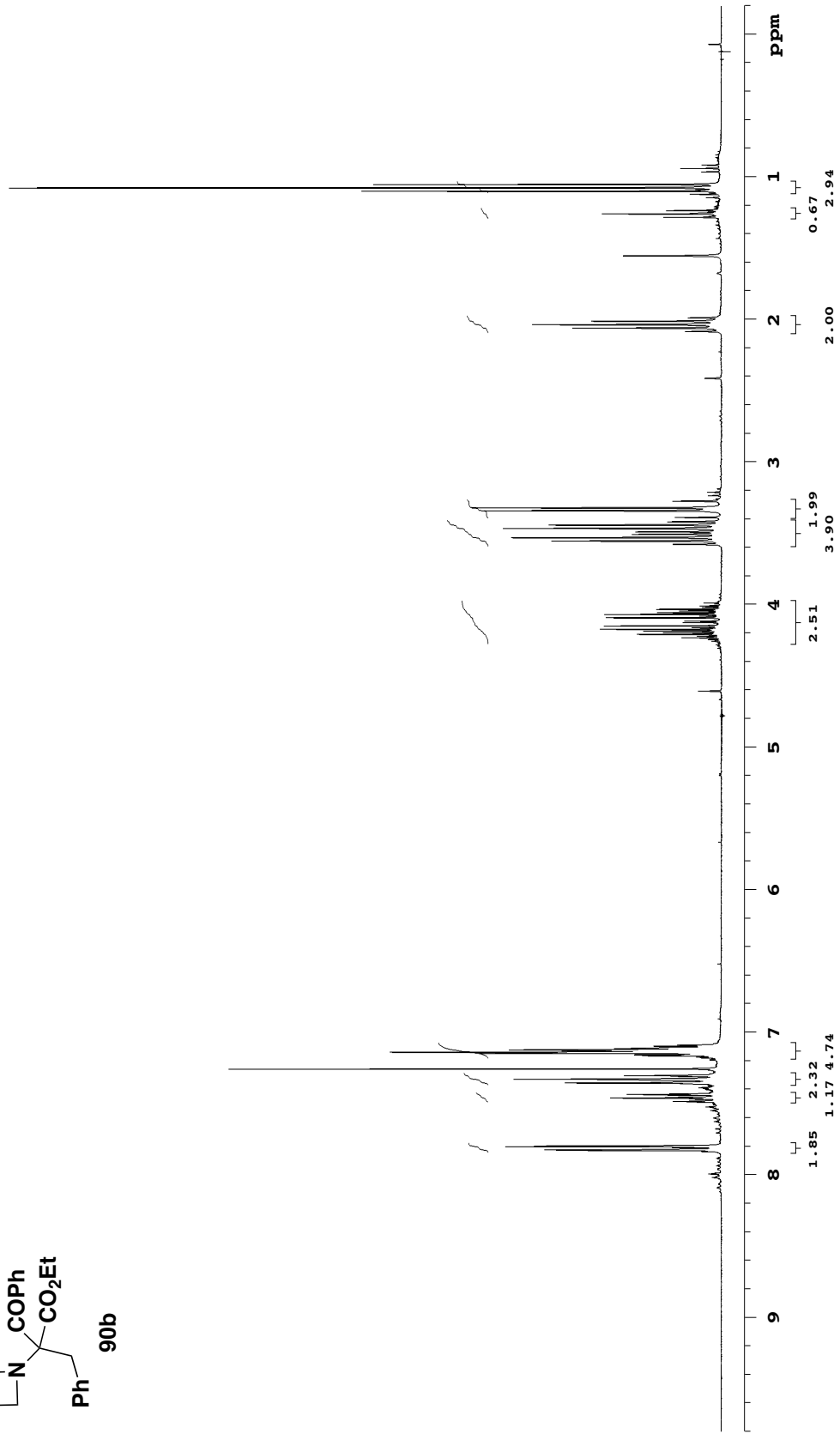
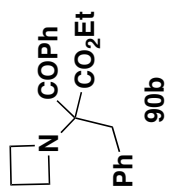

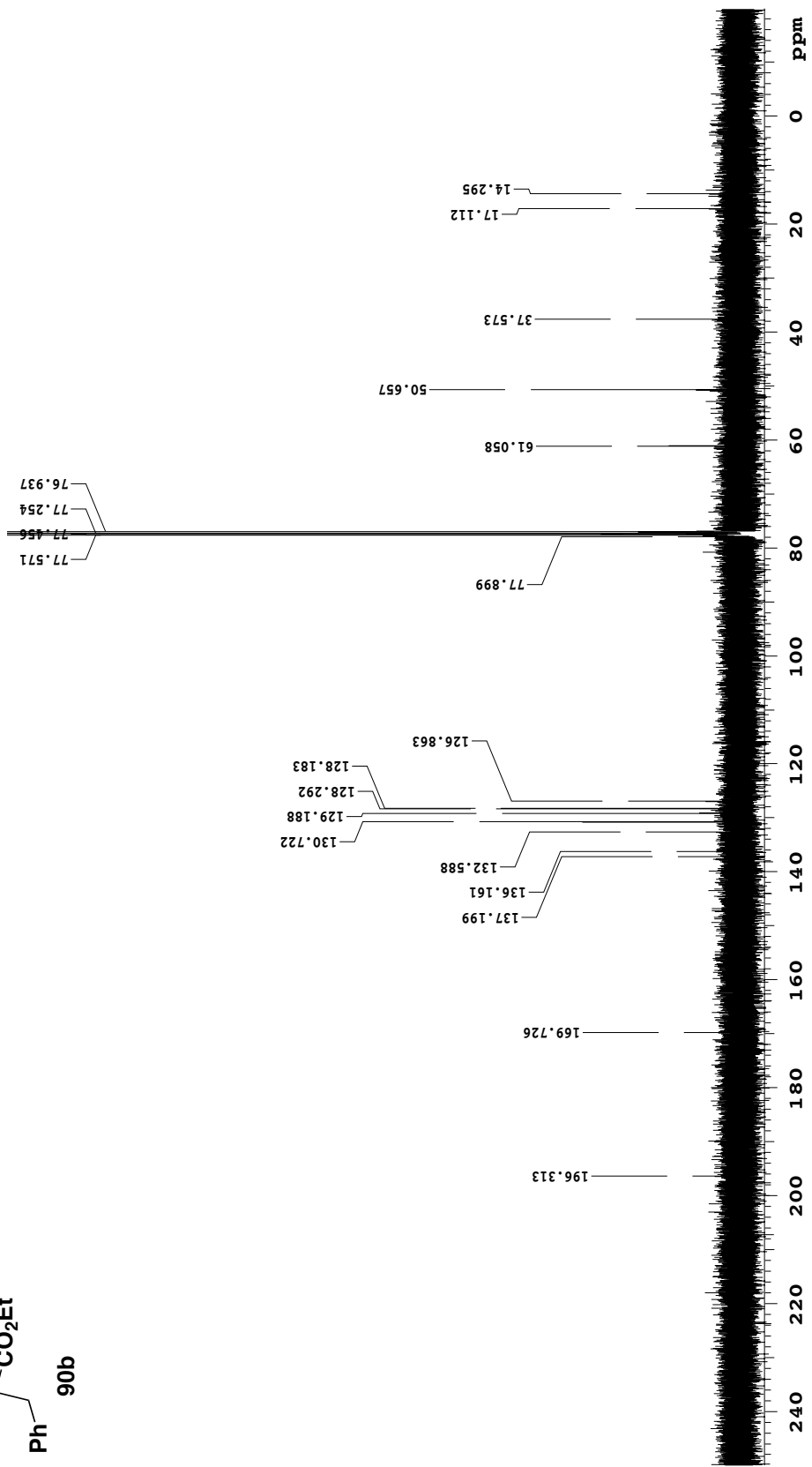
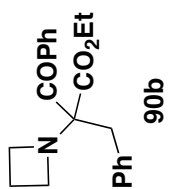

Appendix II: Selected NMR Spectra for Chapter 3

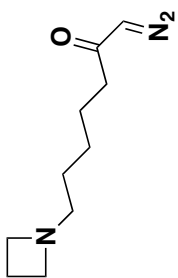

18

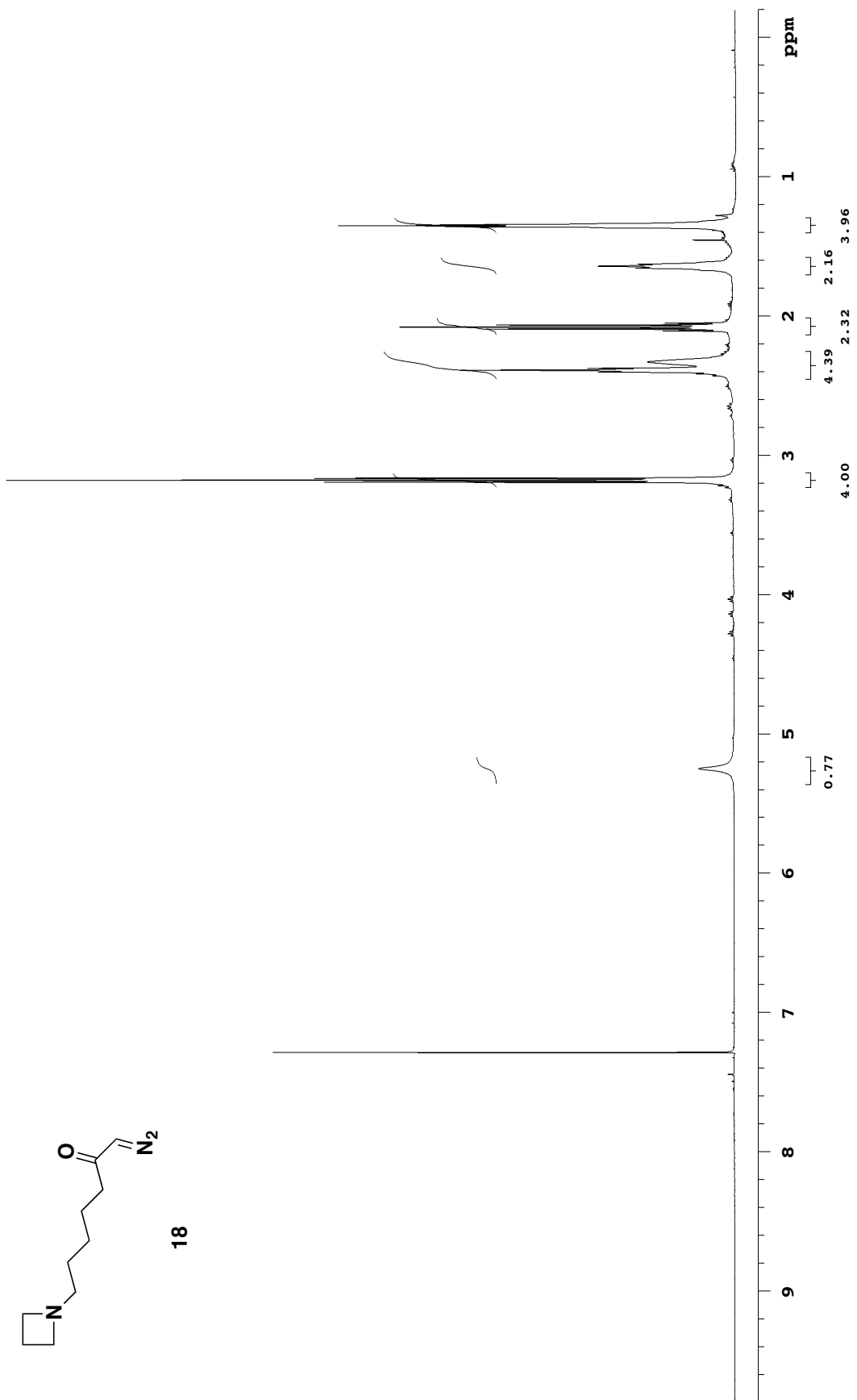

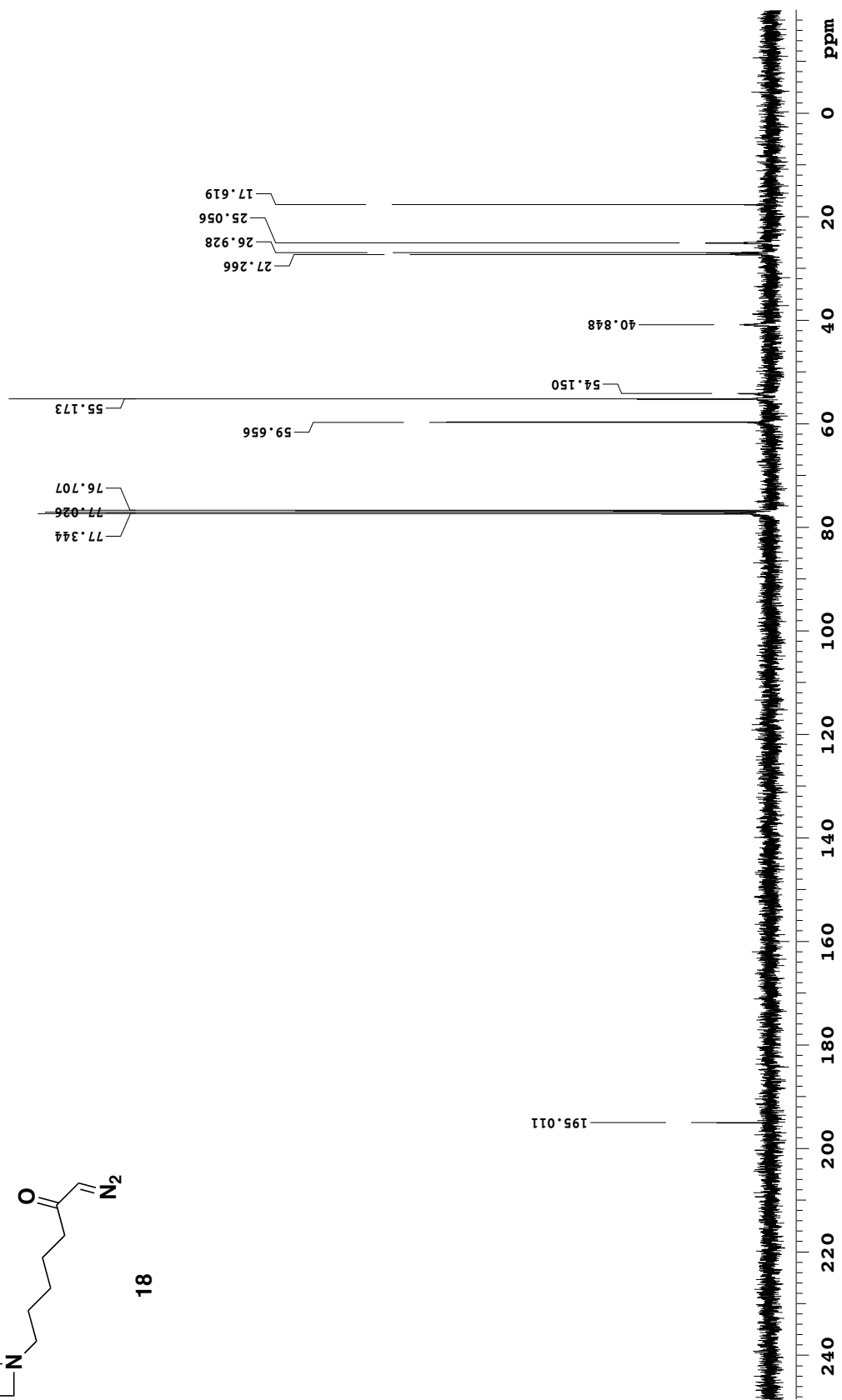
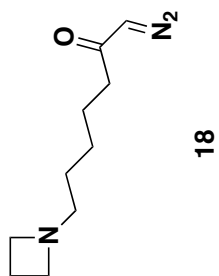

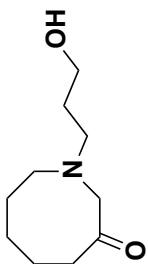

19

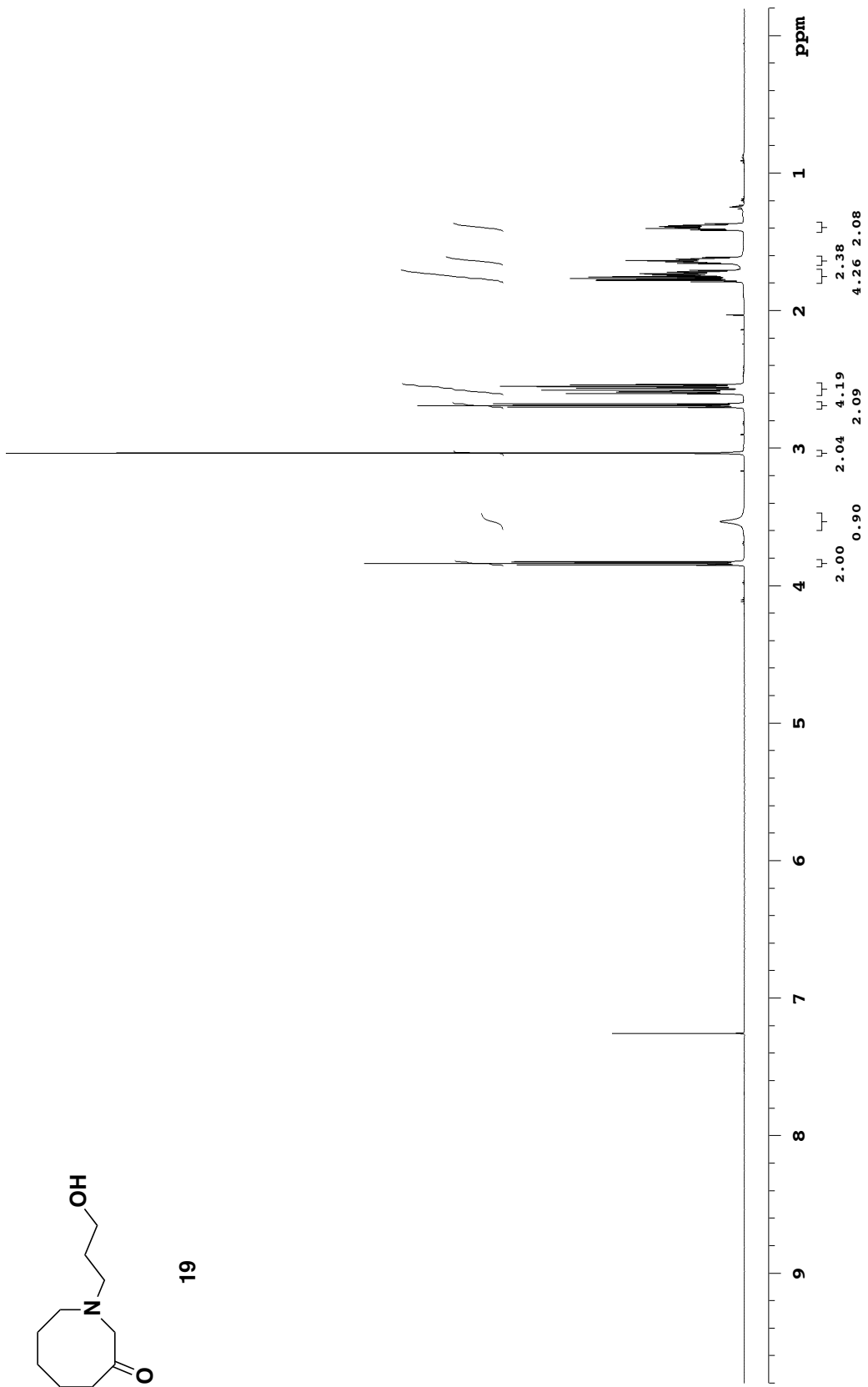

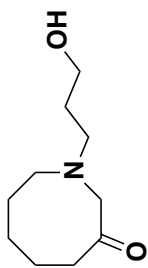

19

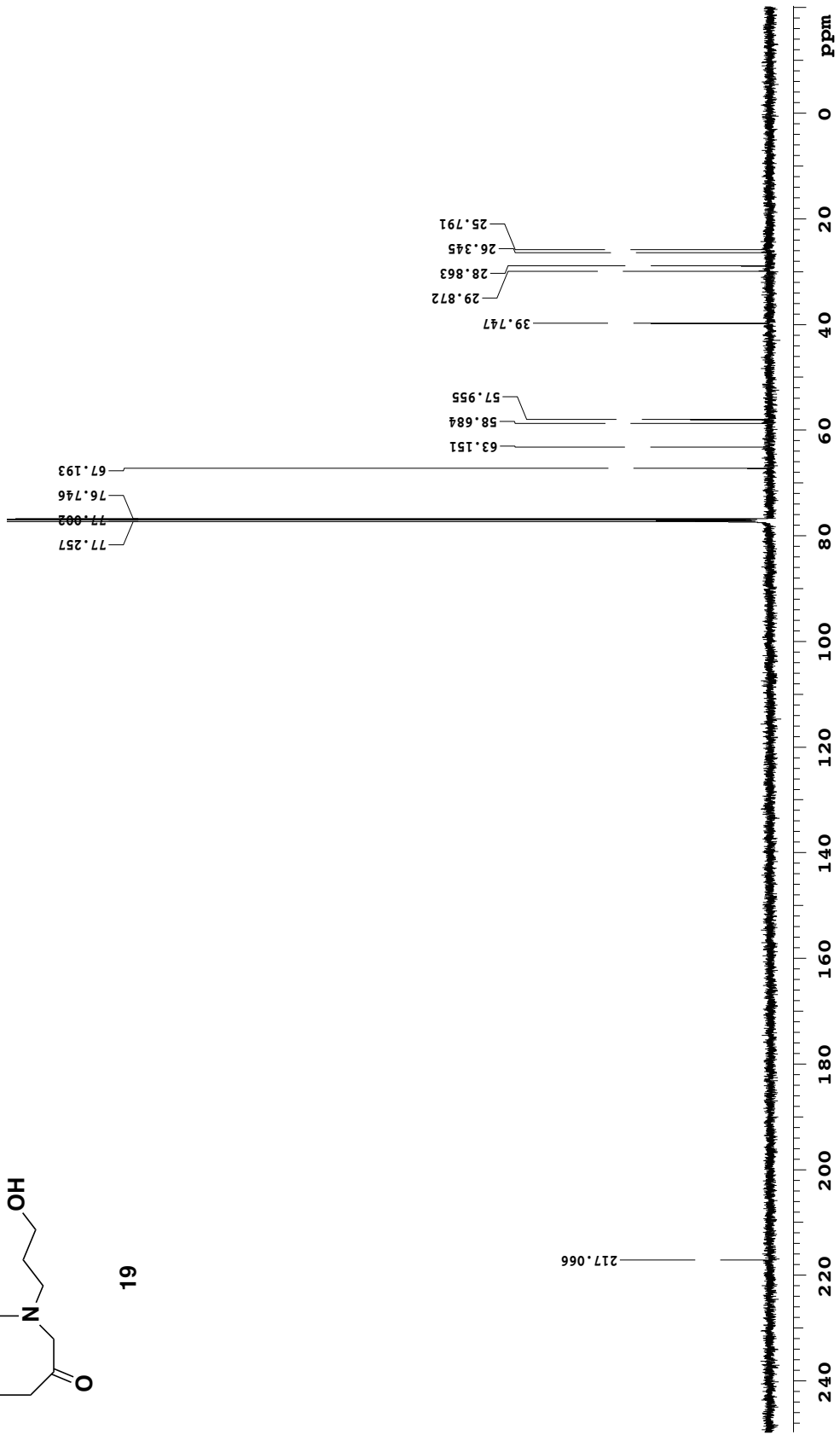

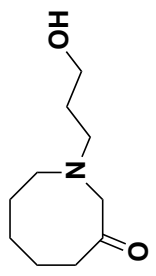
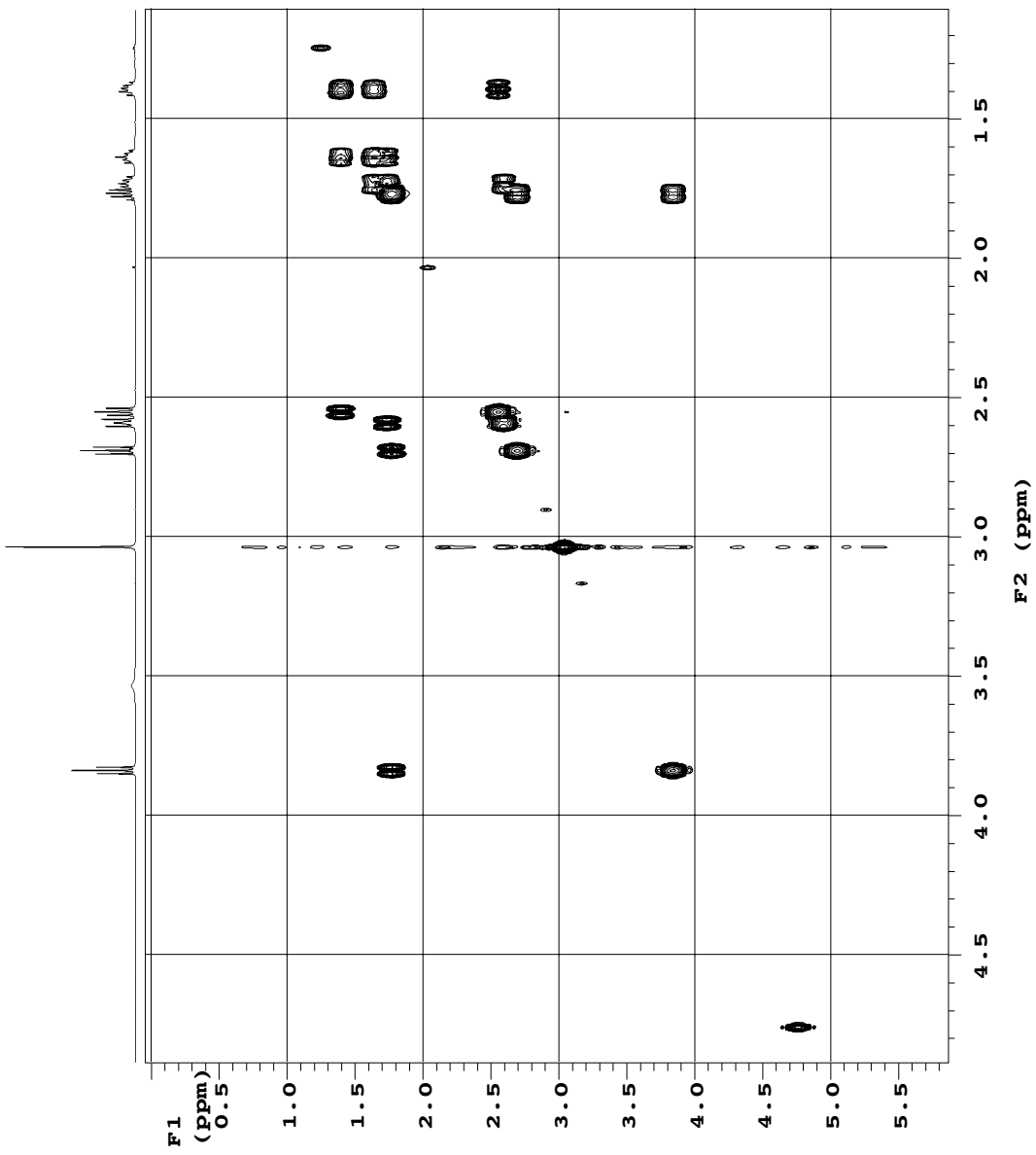

19

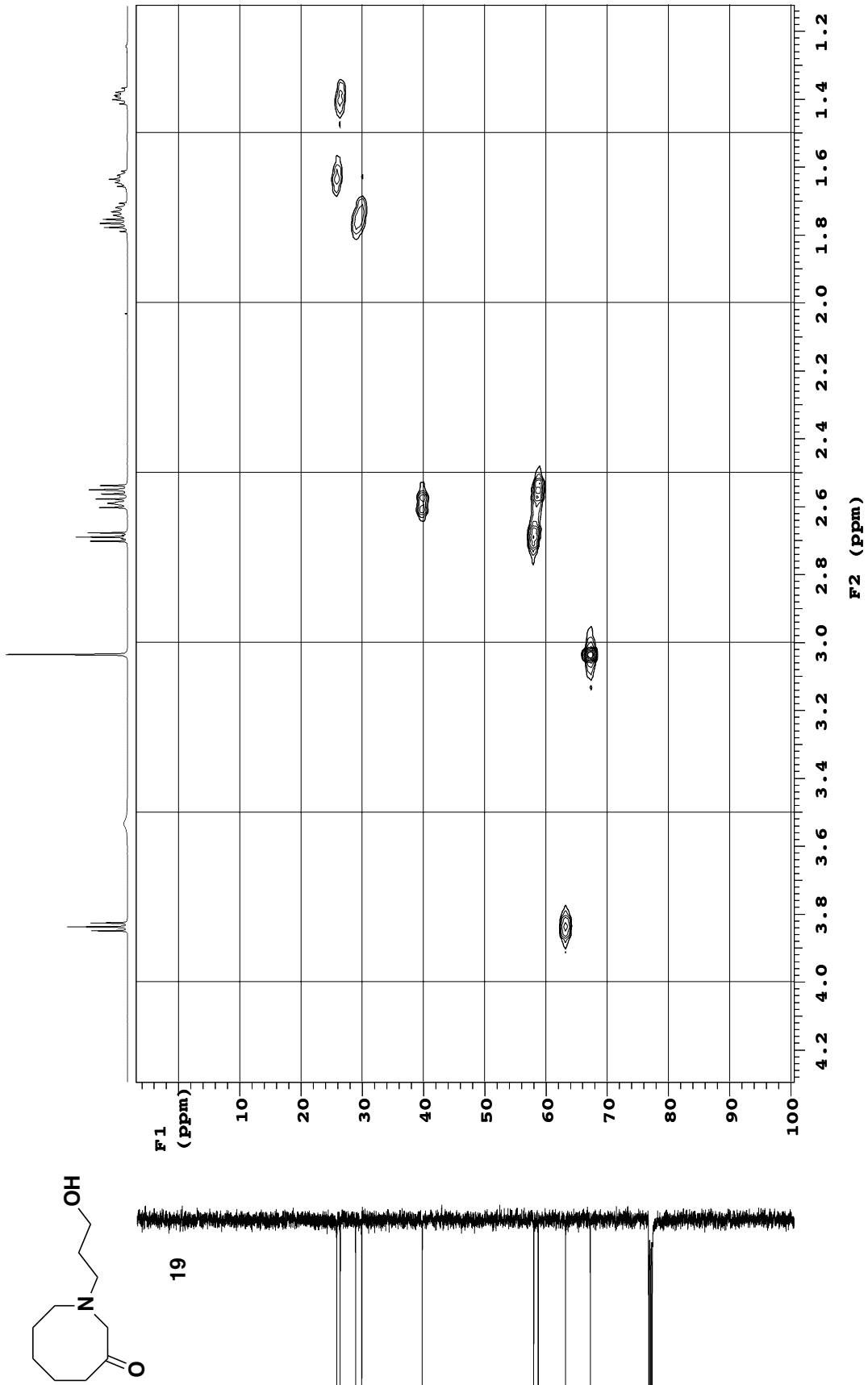

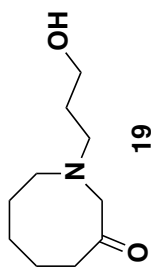

HMBC

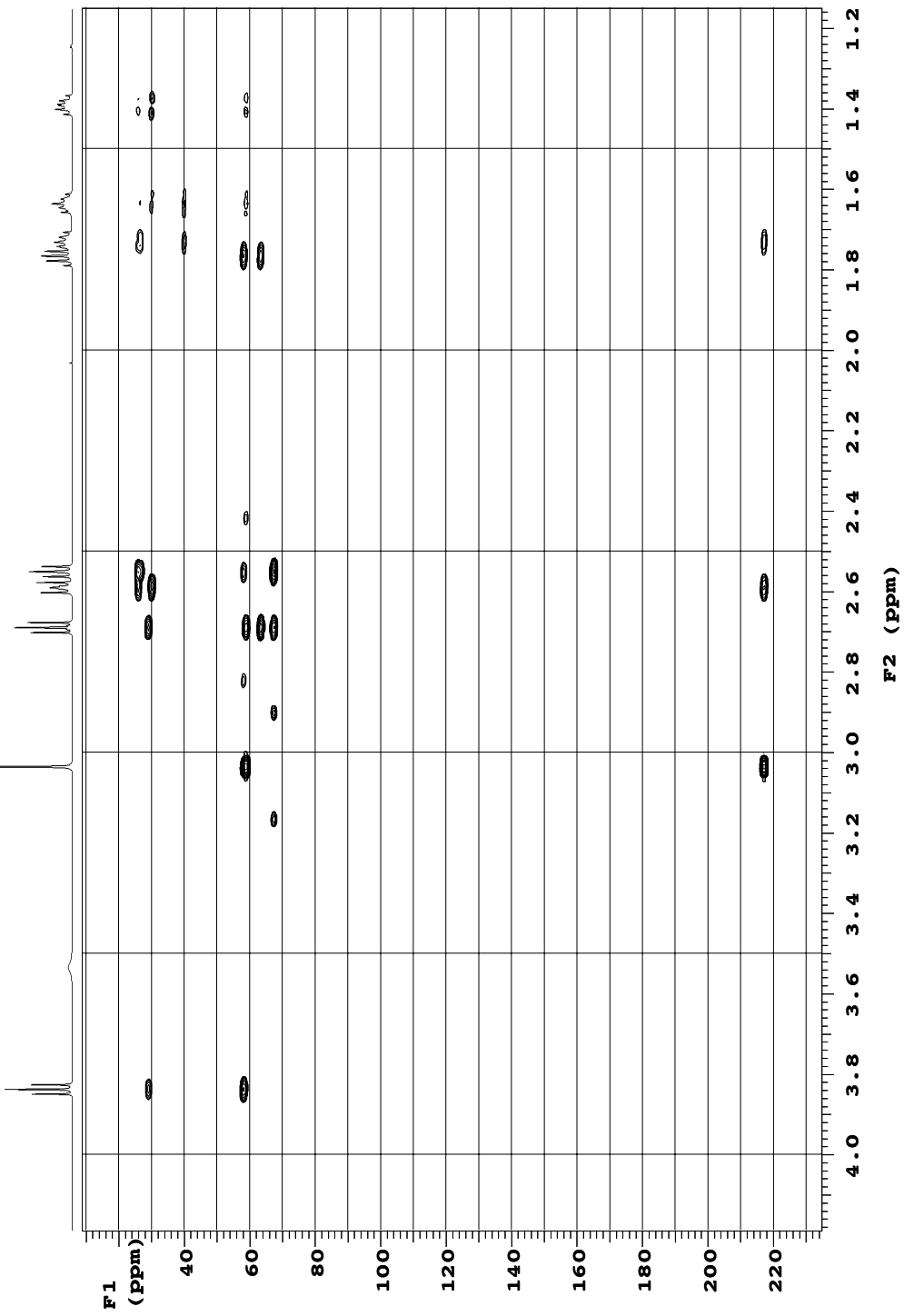

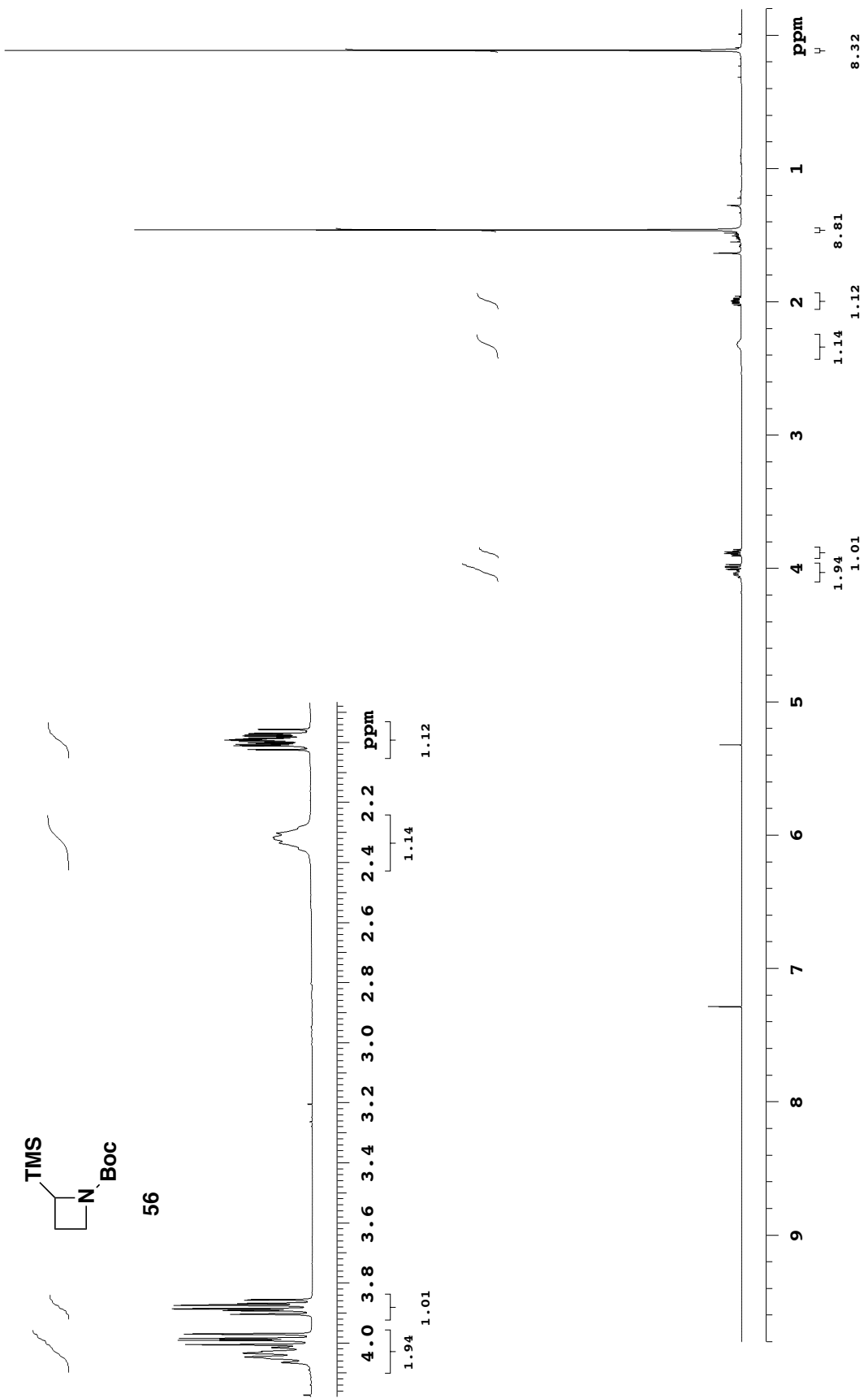

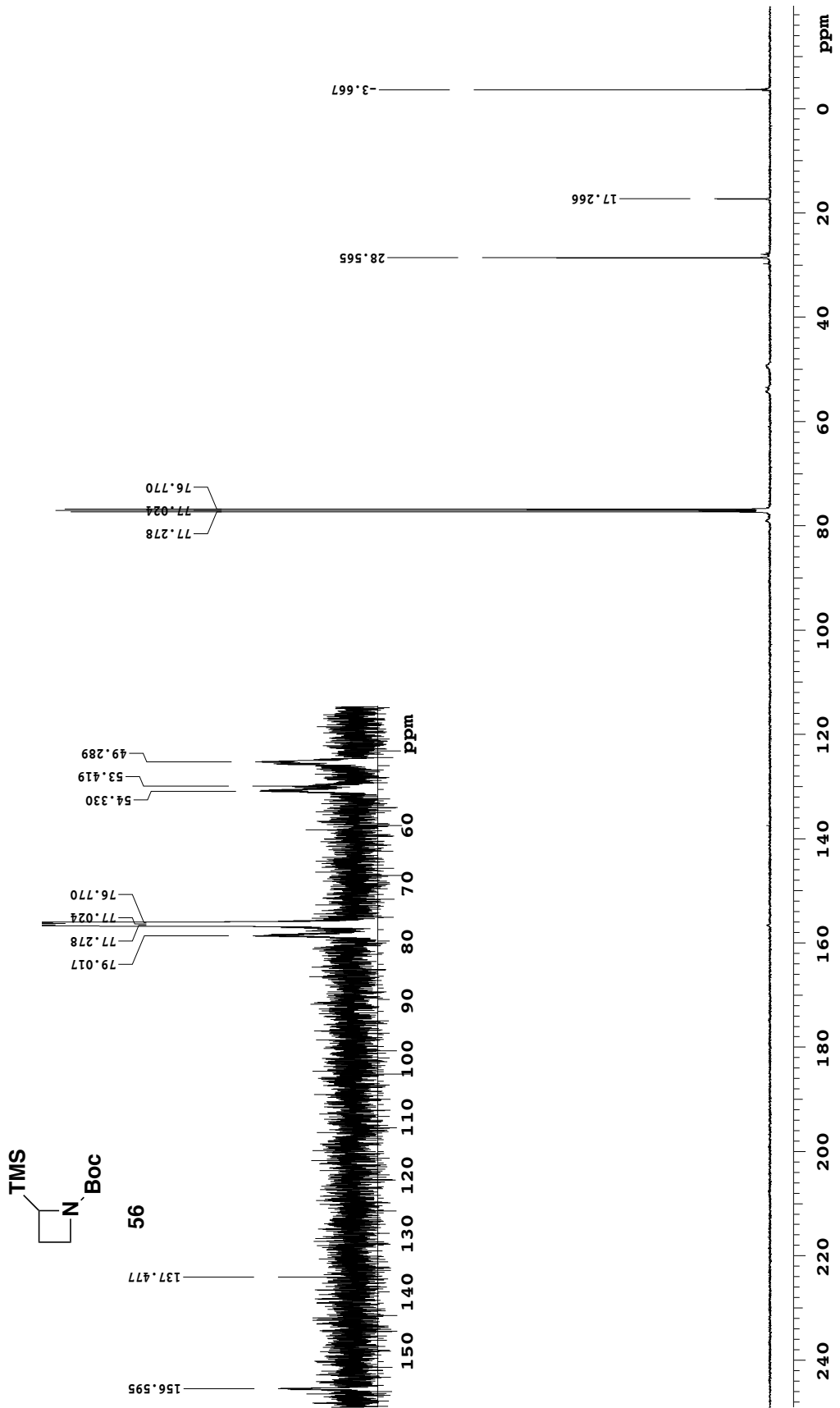

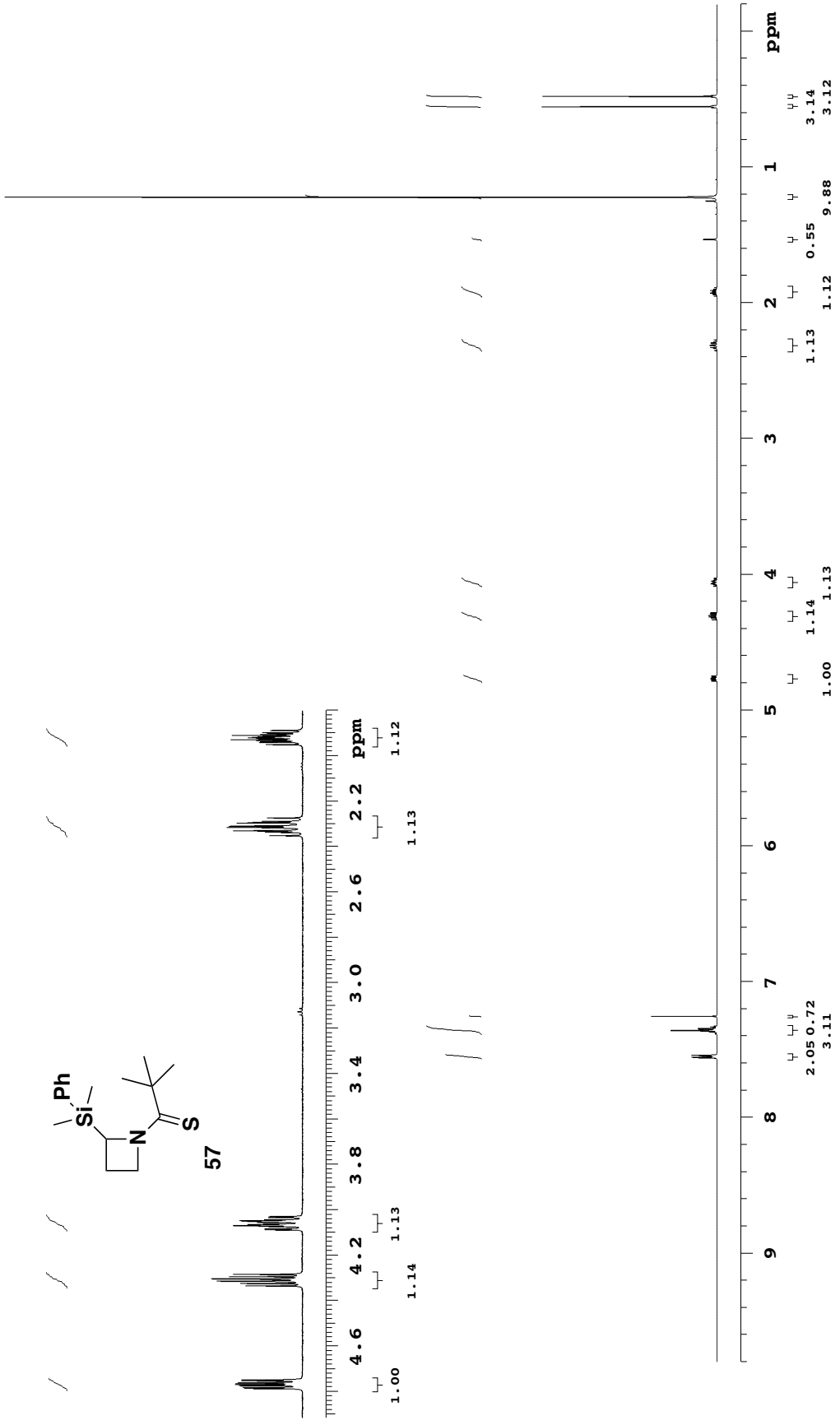
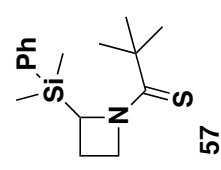

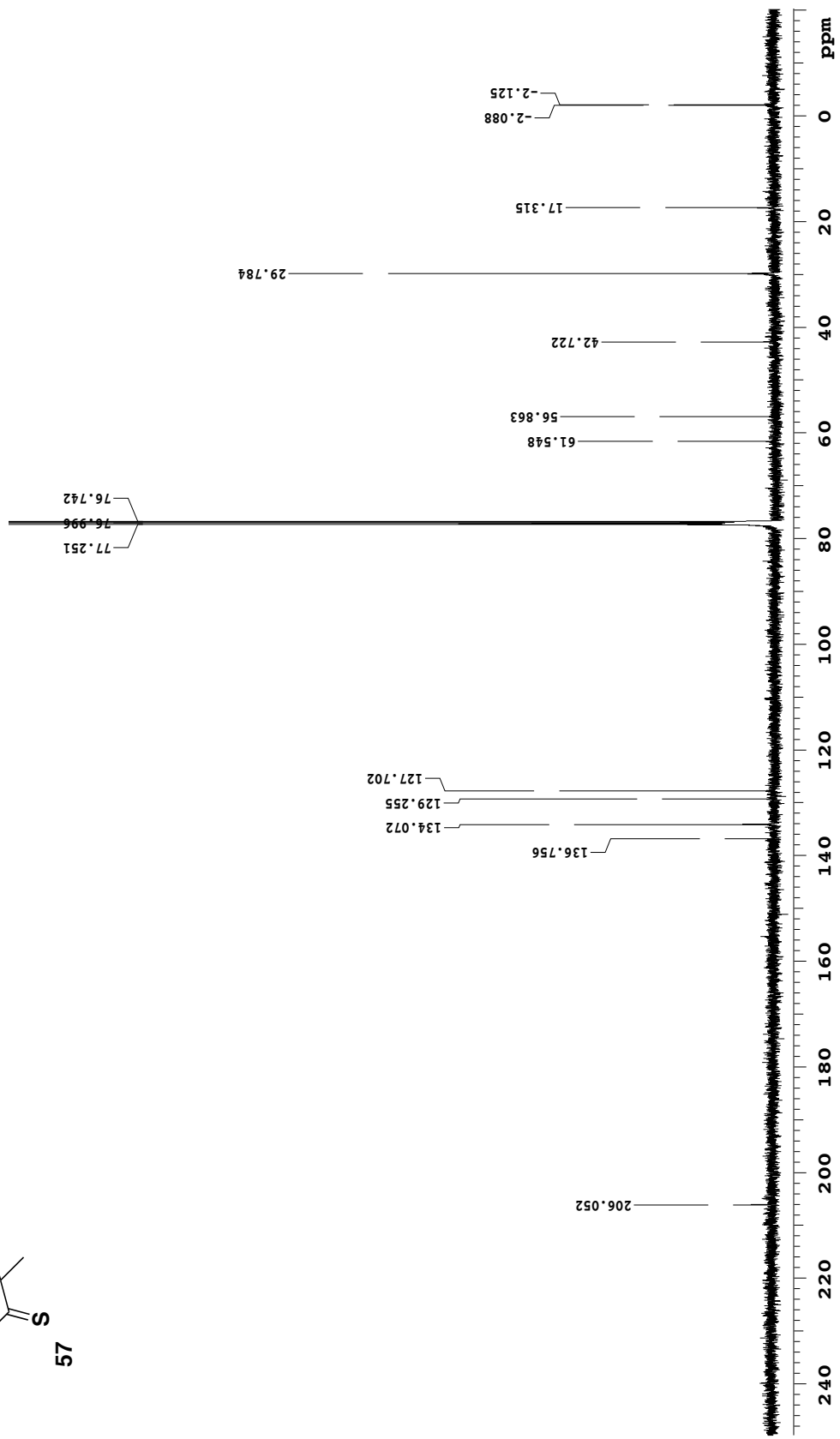
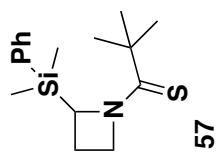

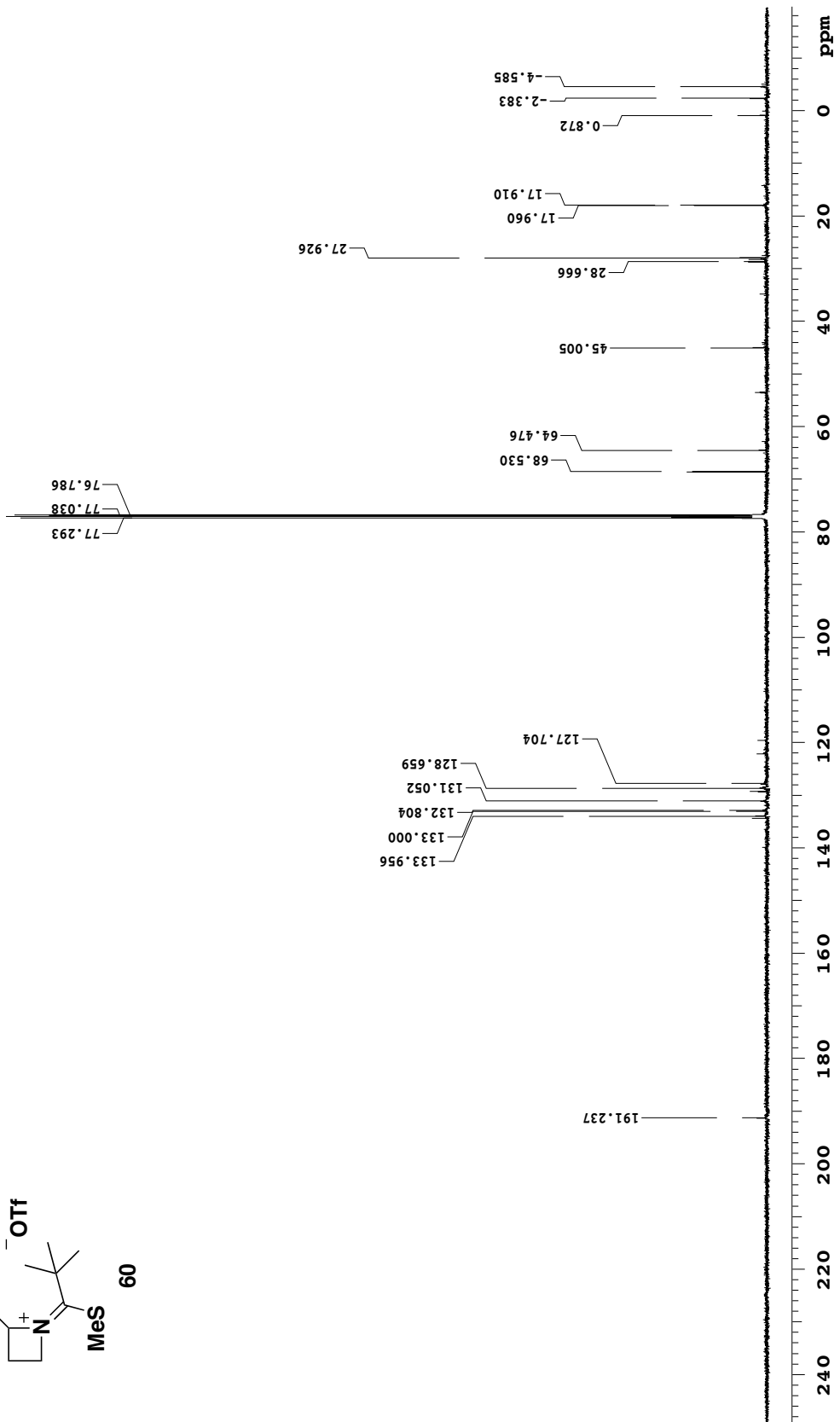
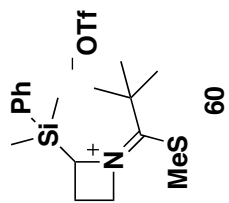

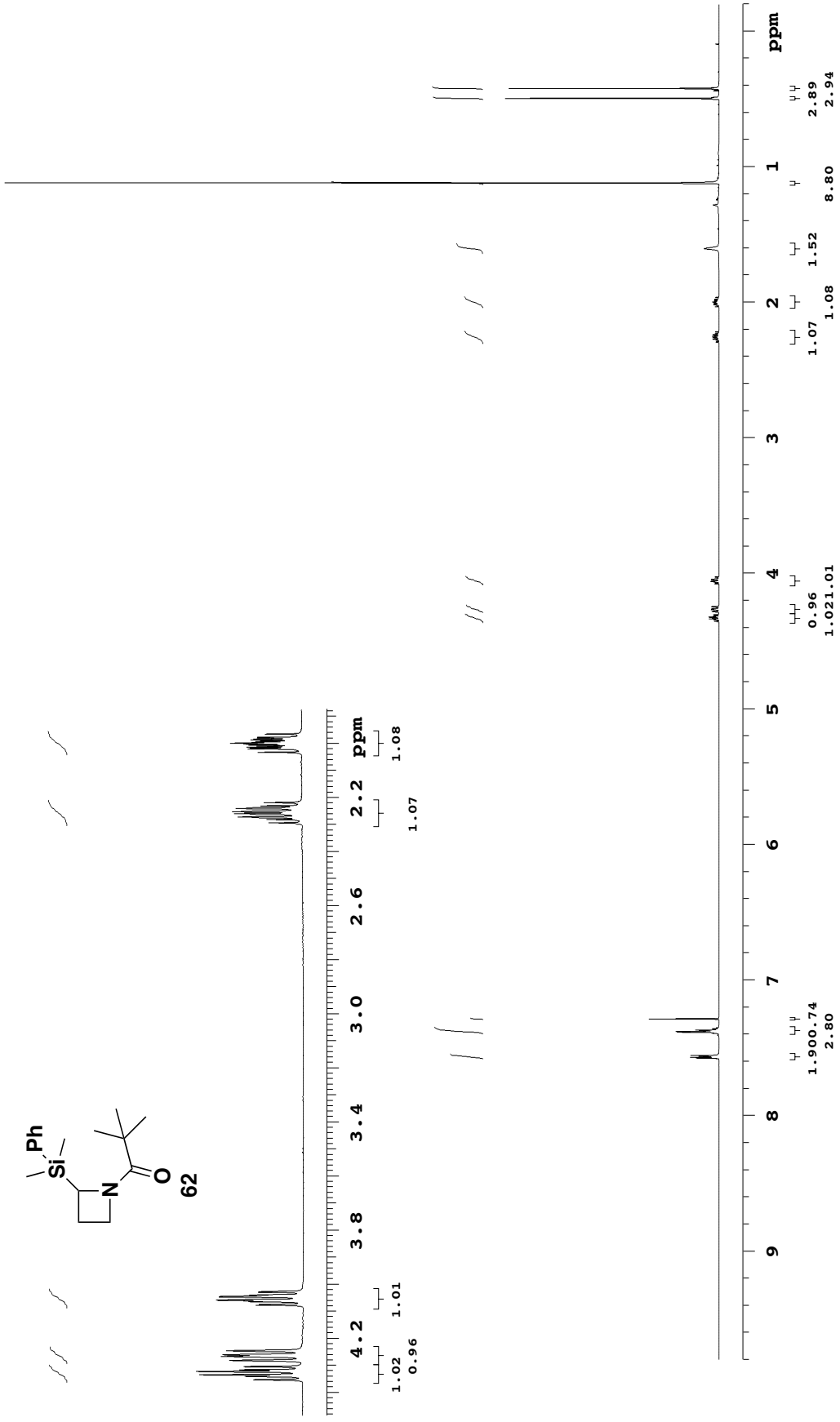
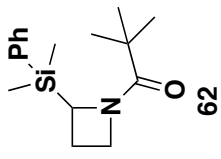

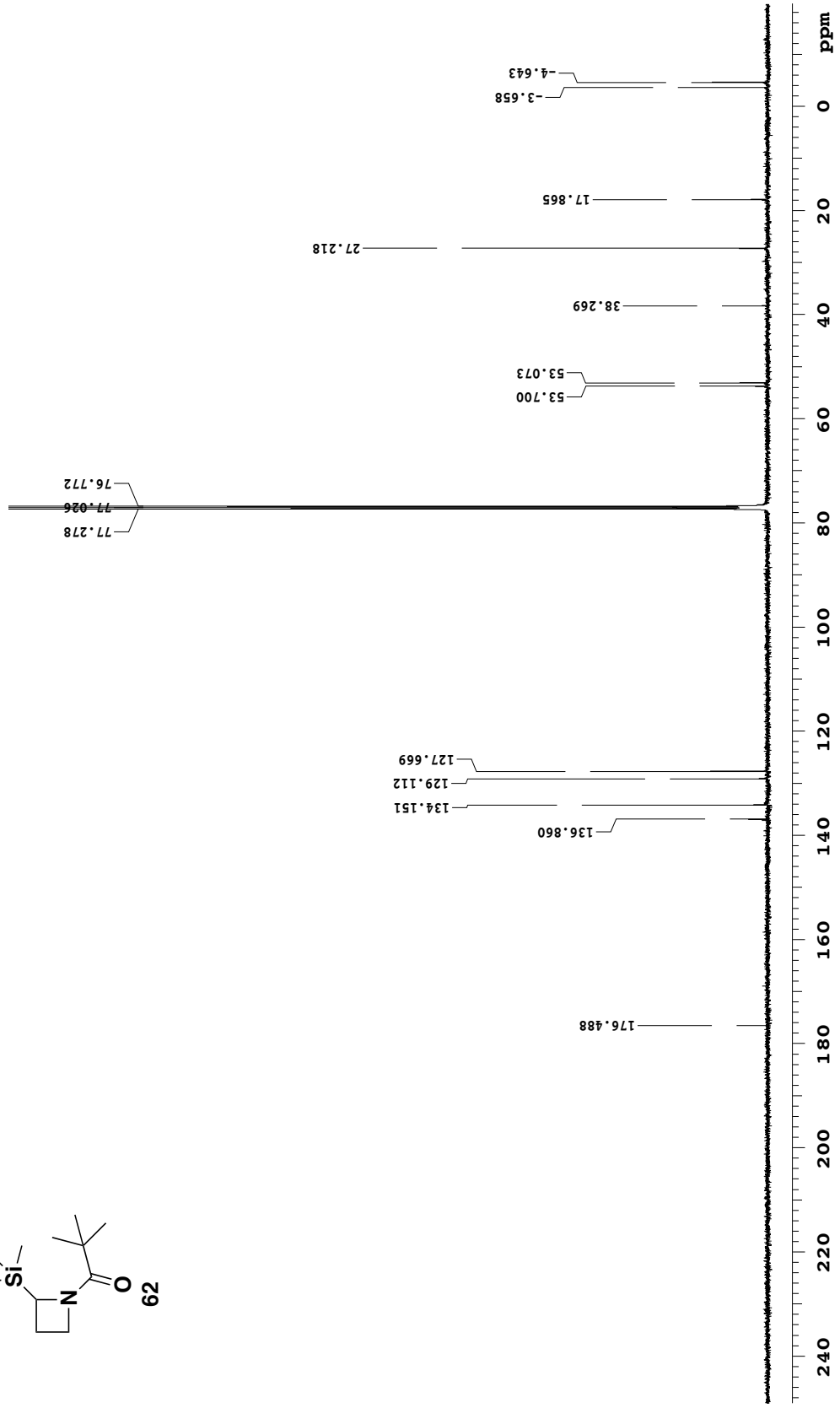
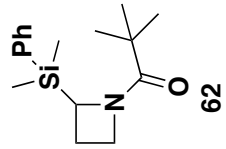

Appendix III: Selected NMR Spectra for Chapter 4

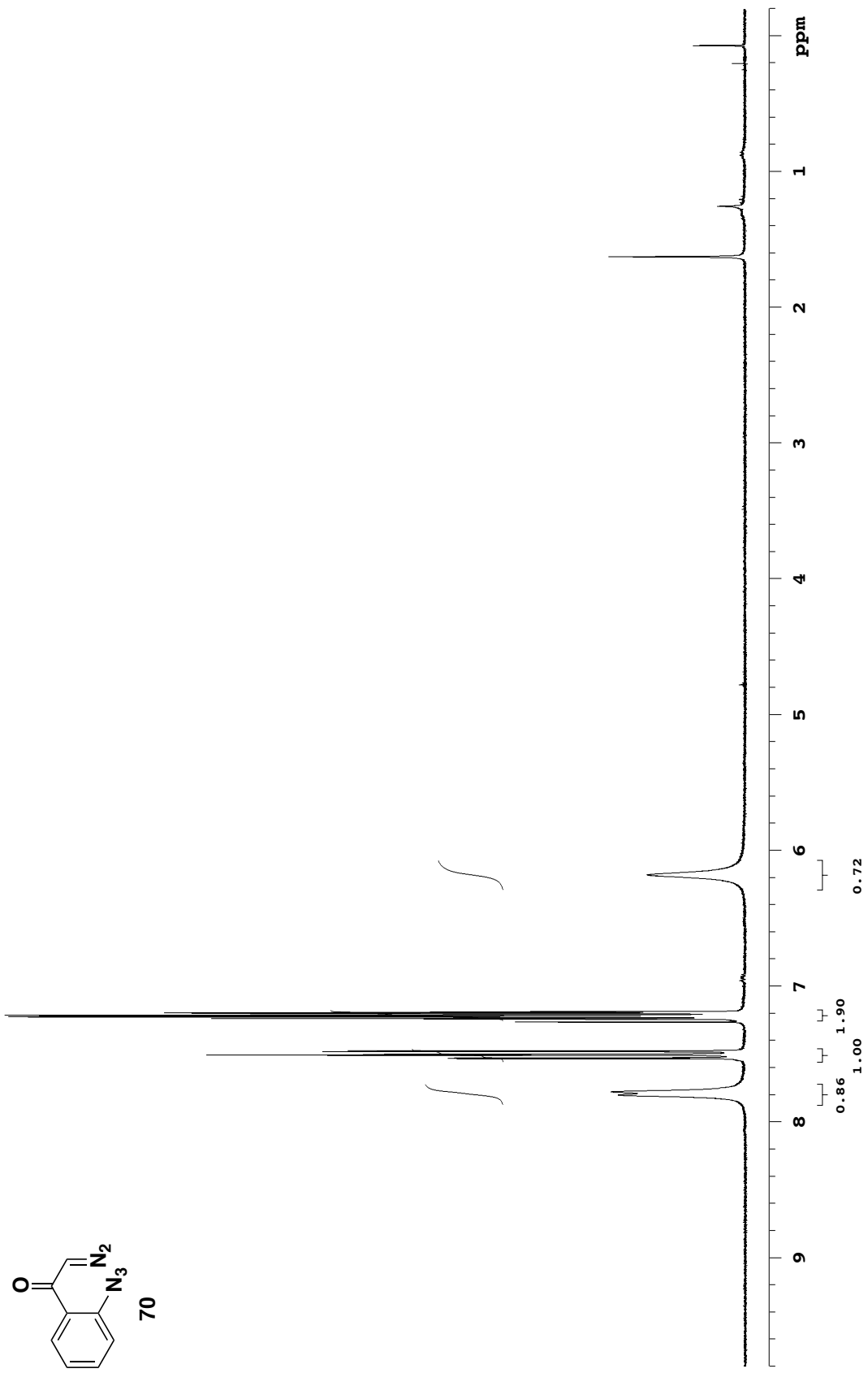
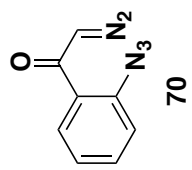

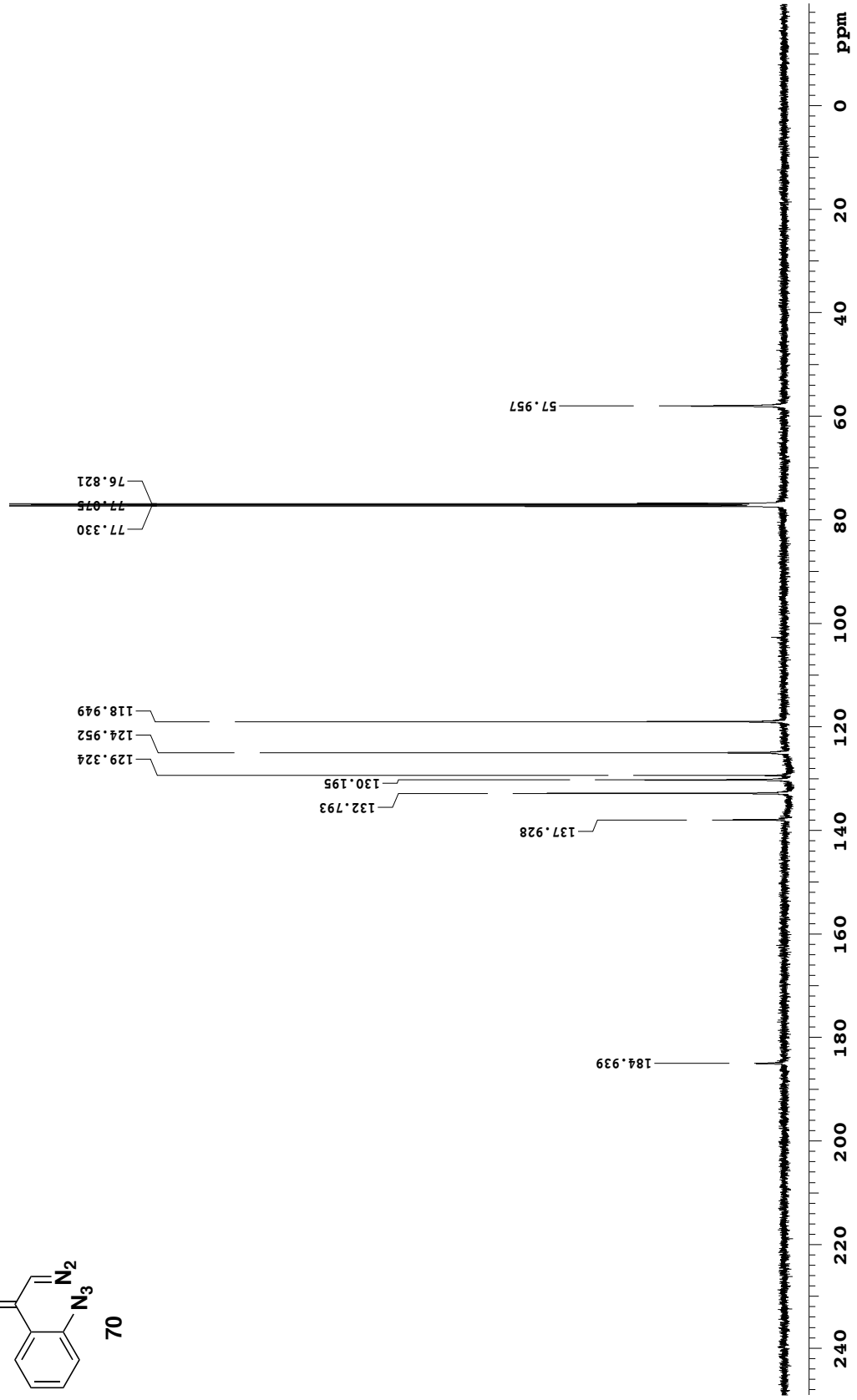
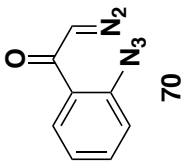

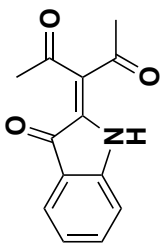

71

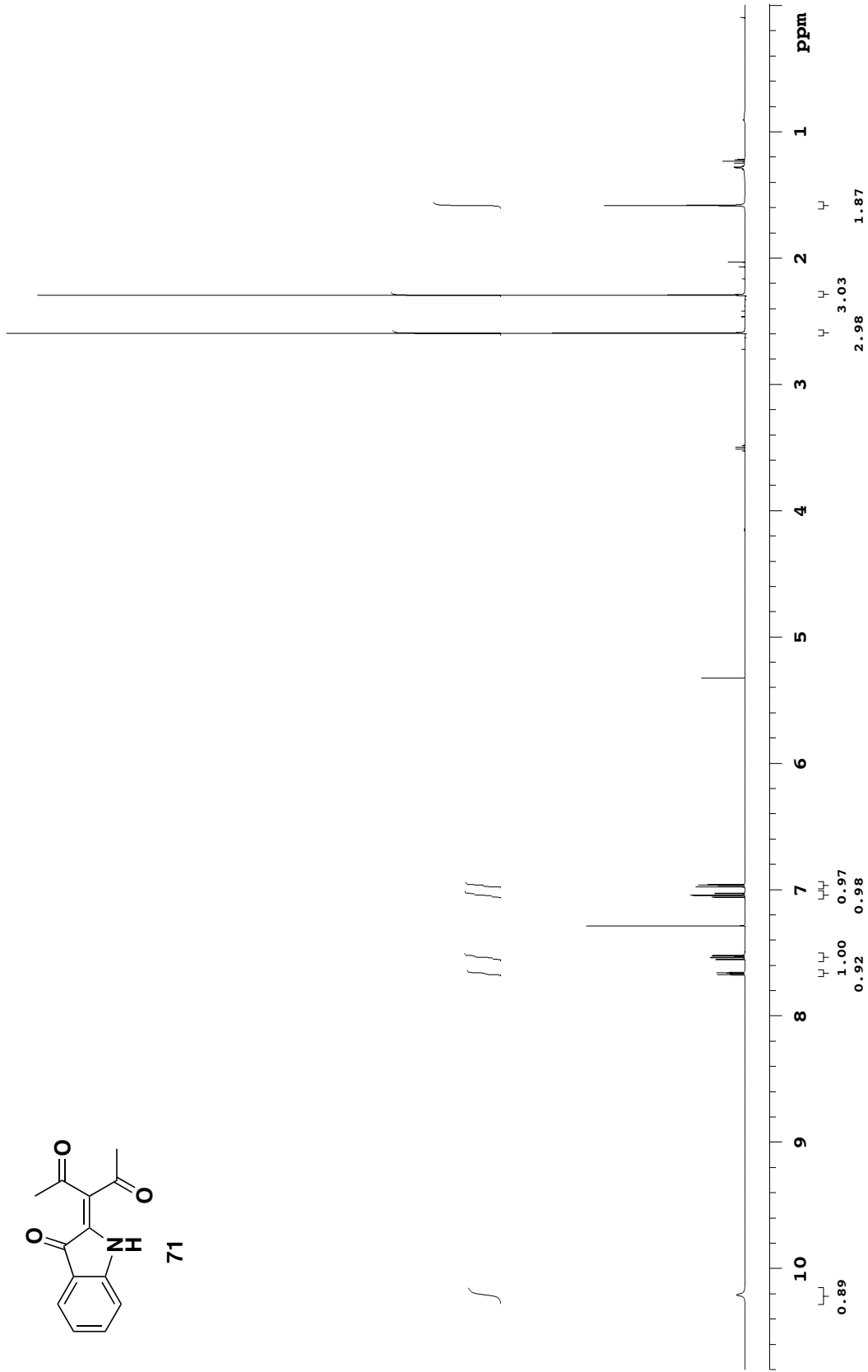

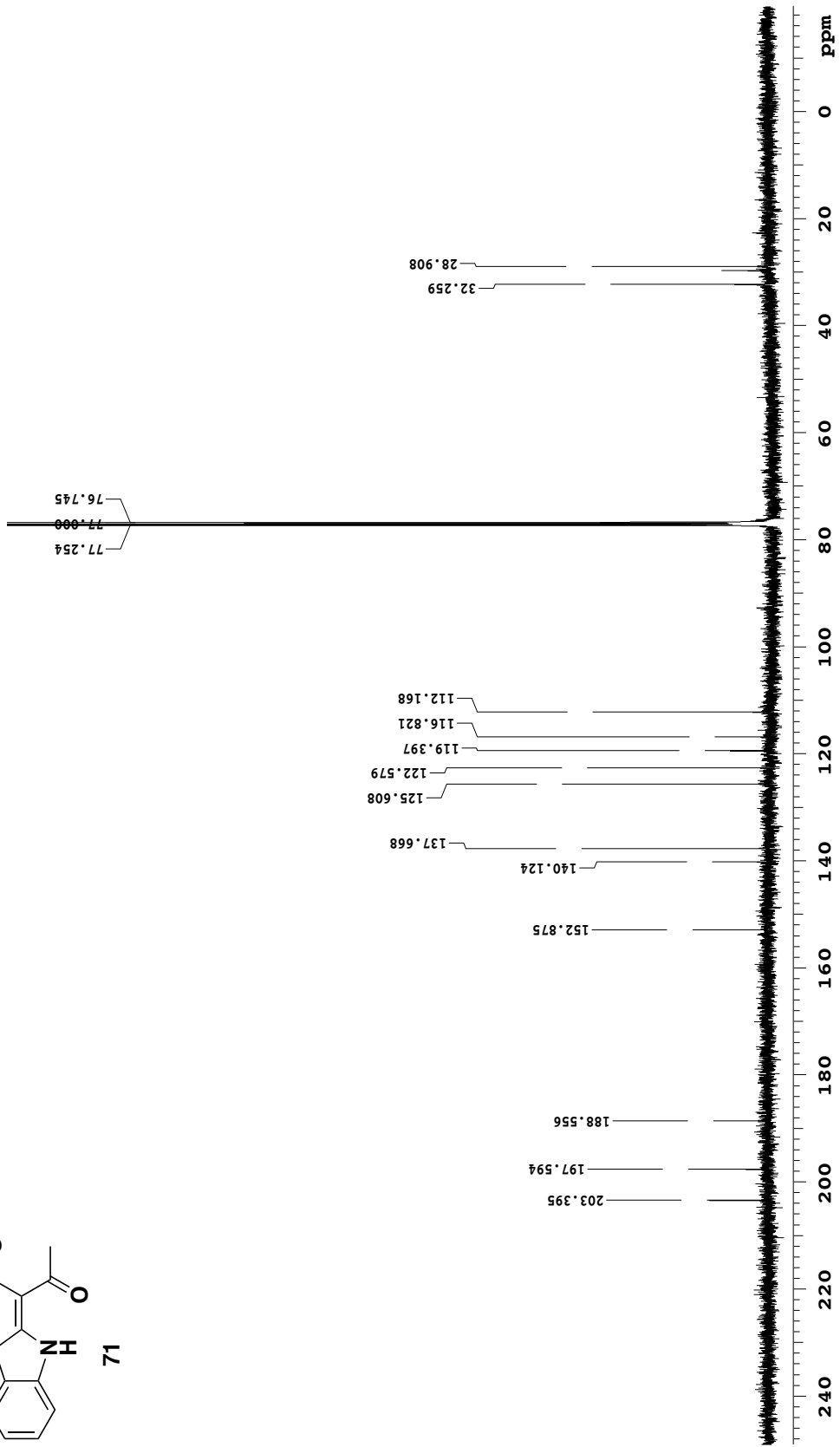
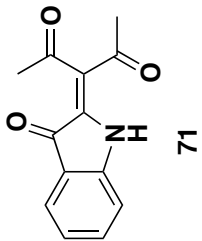

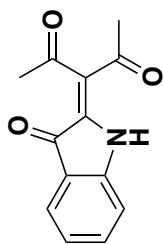

71

HMQC

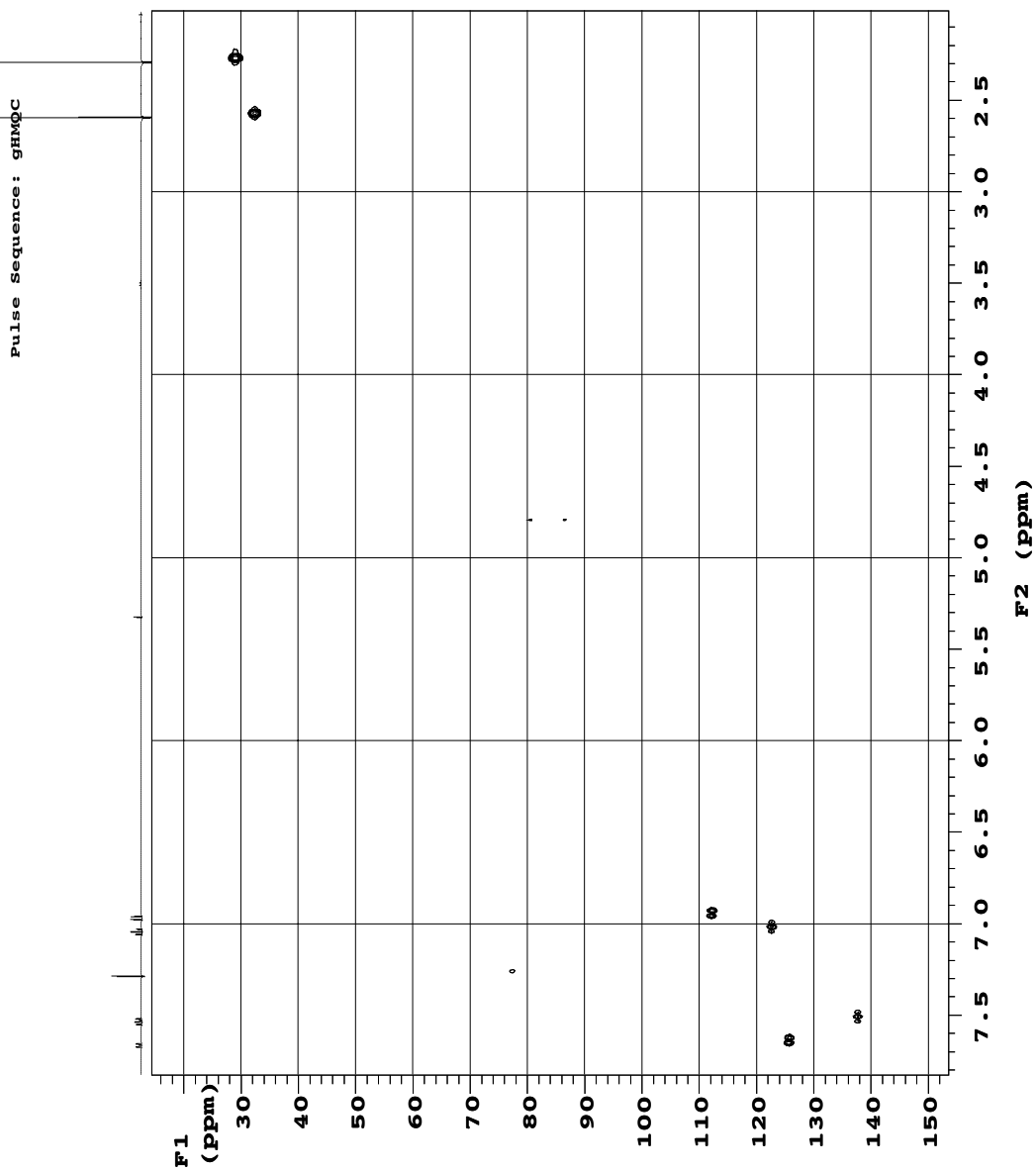

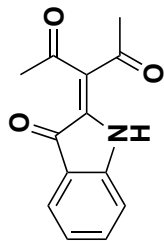

71

HMBC

Pulse Sequence: ghmhc

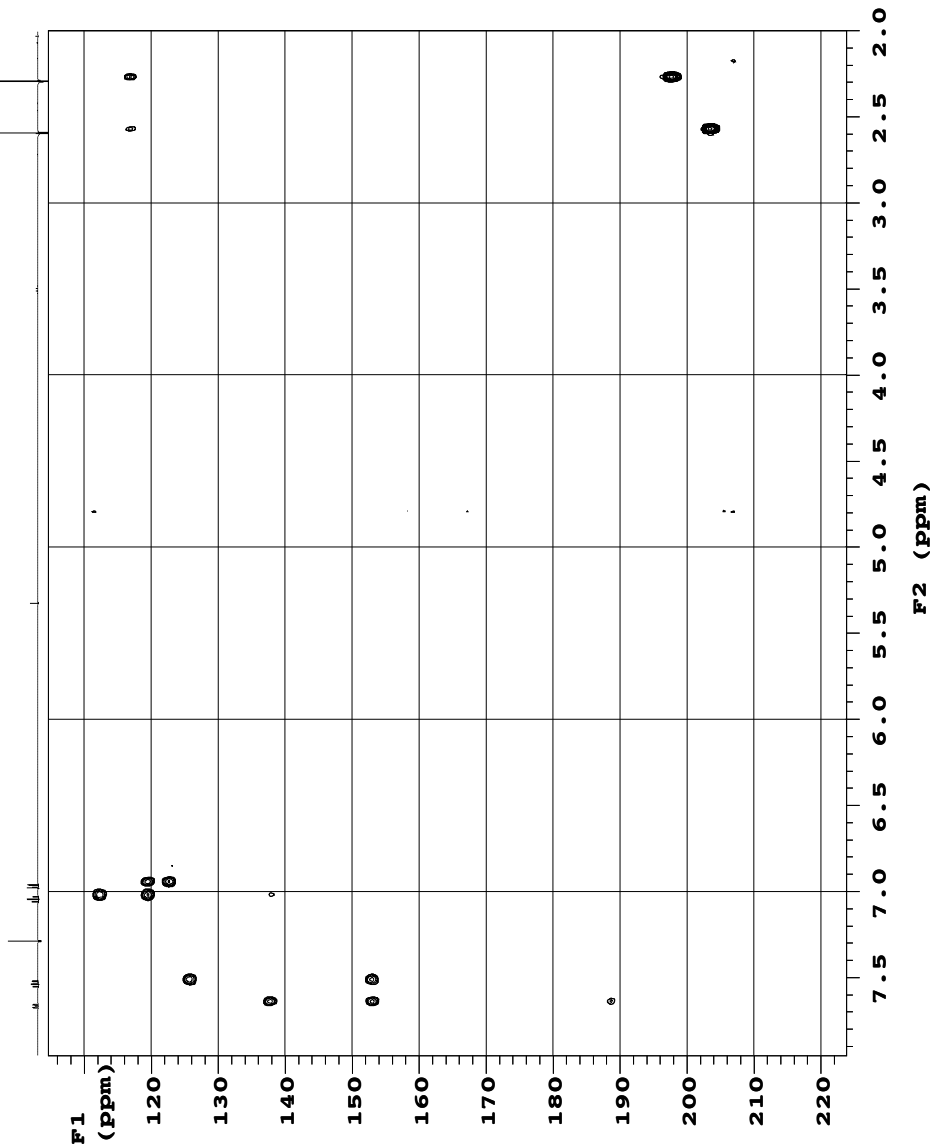

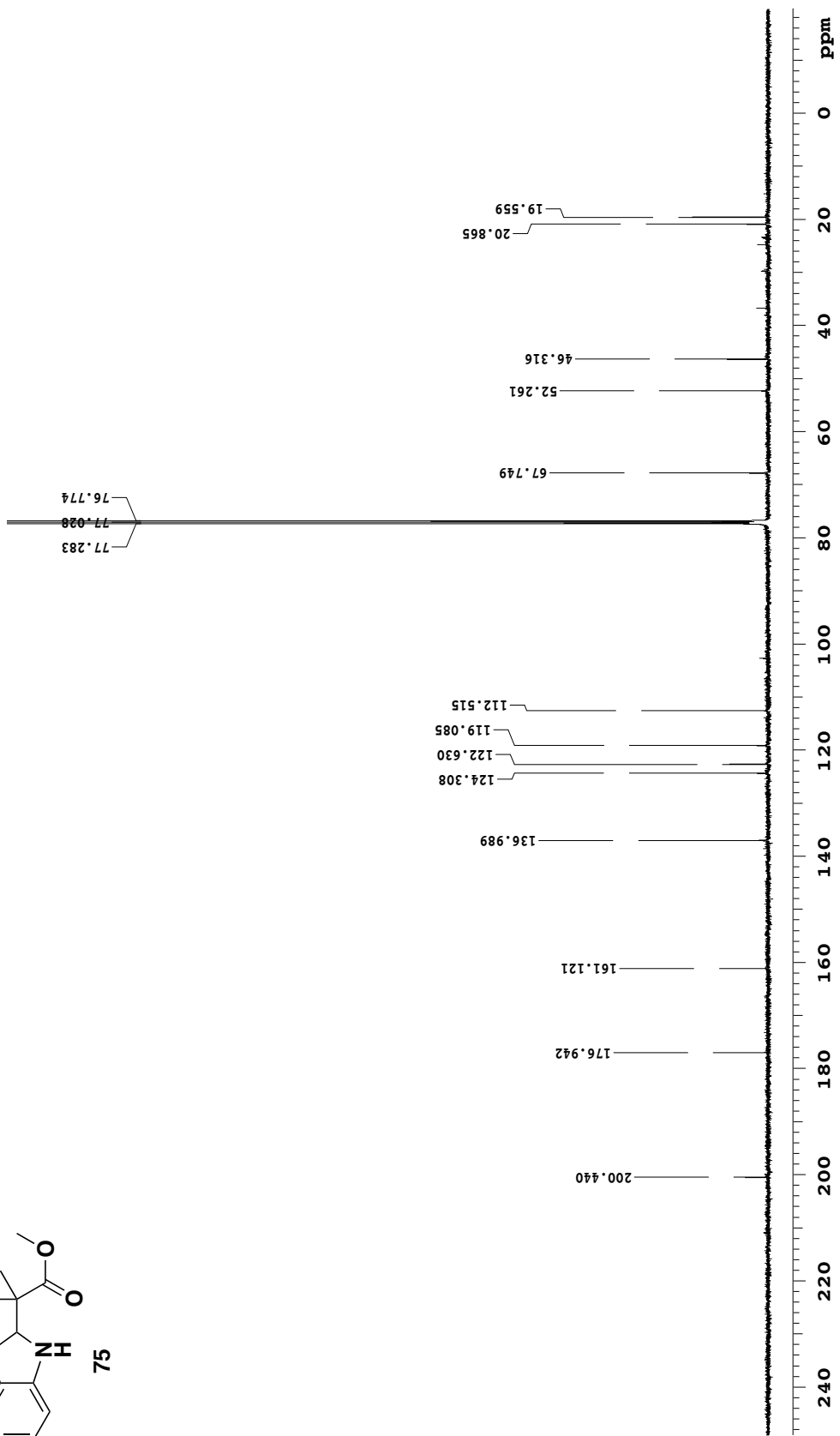
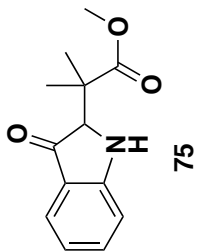

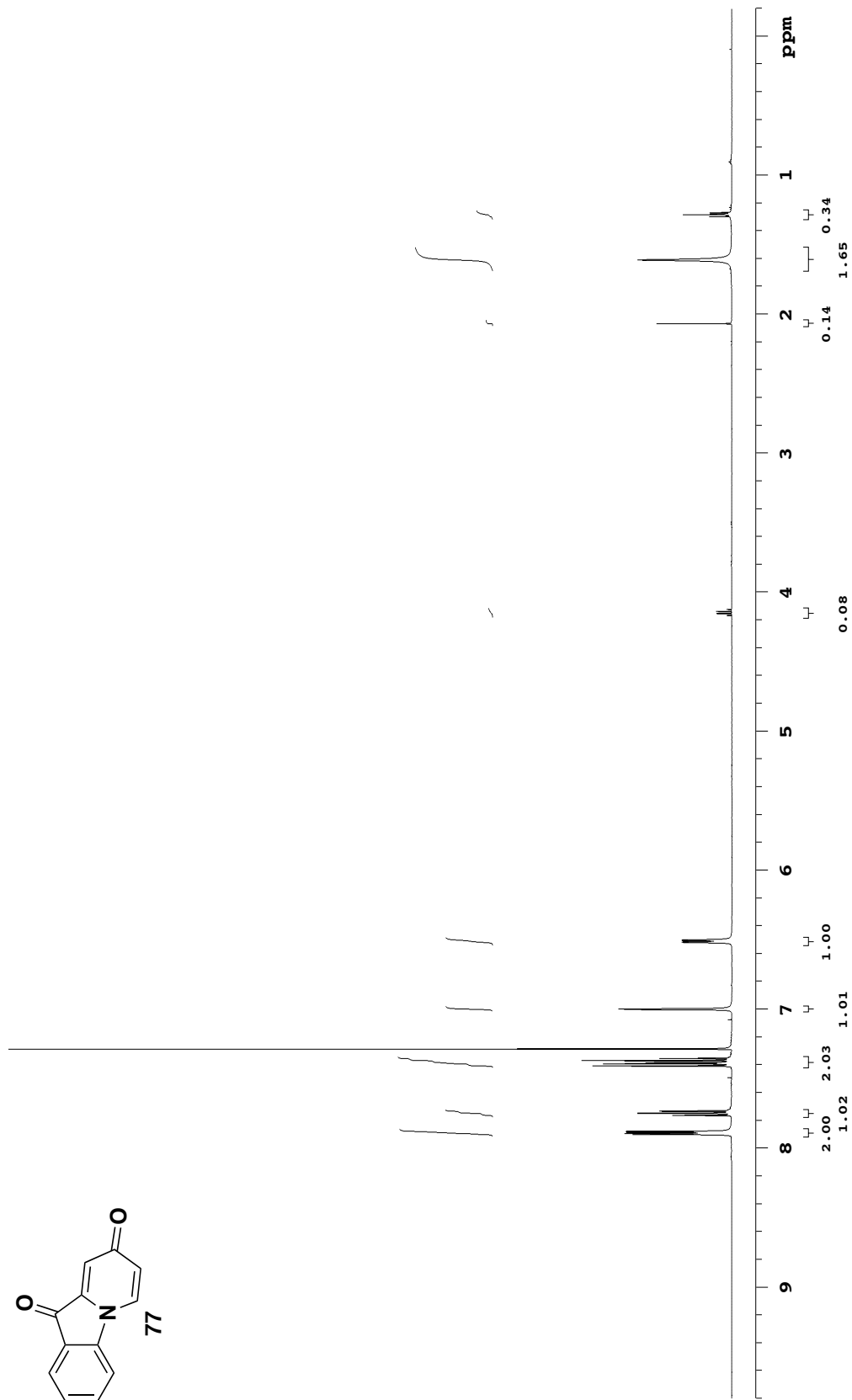
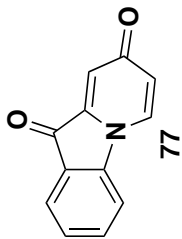

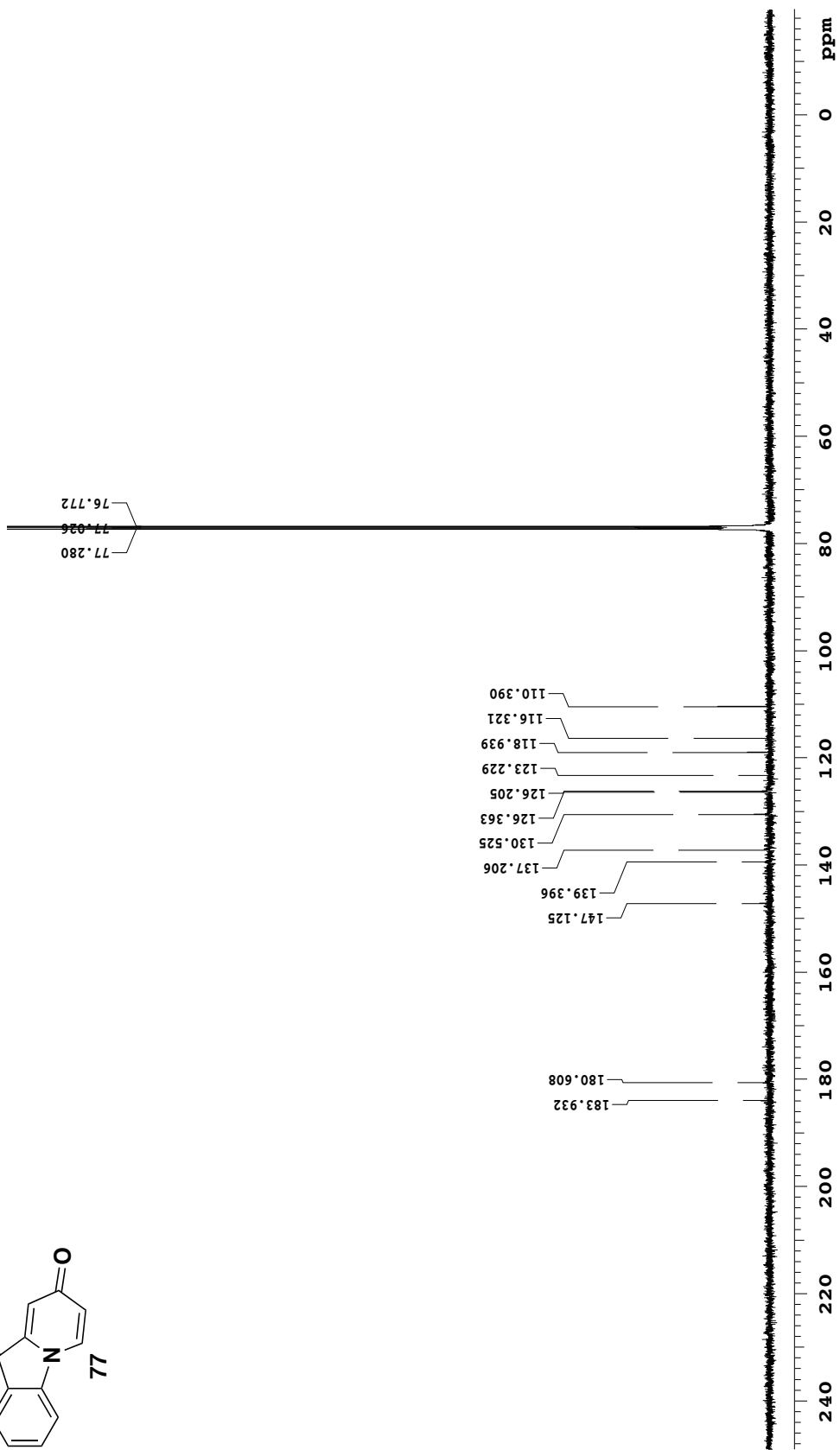
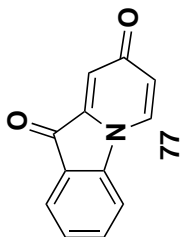

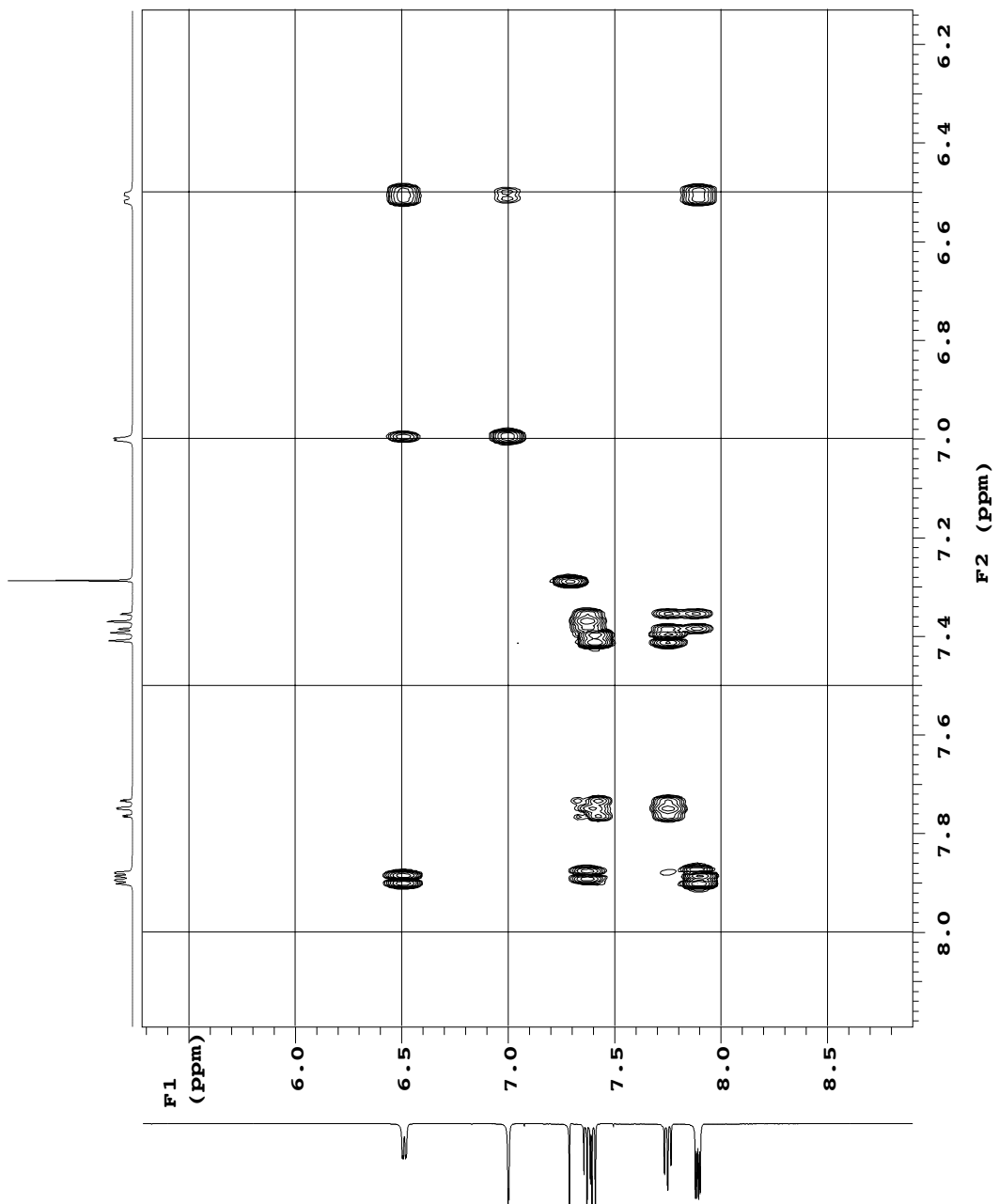
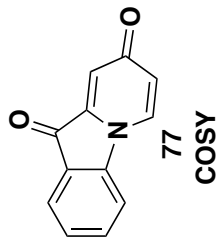

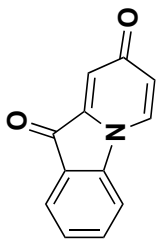

77

HMOC

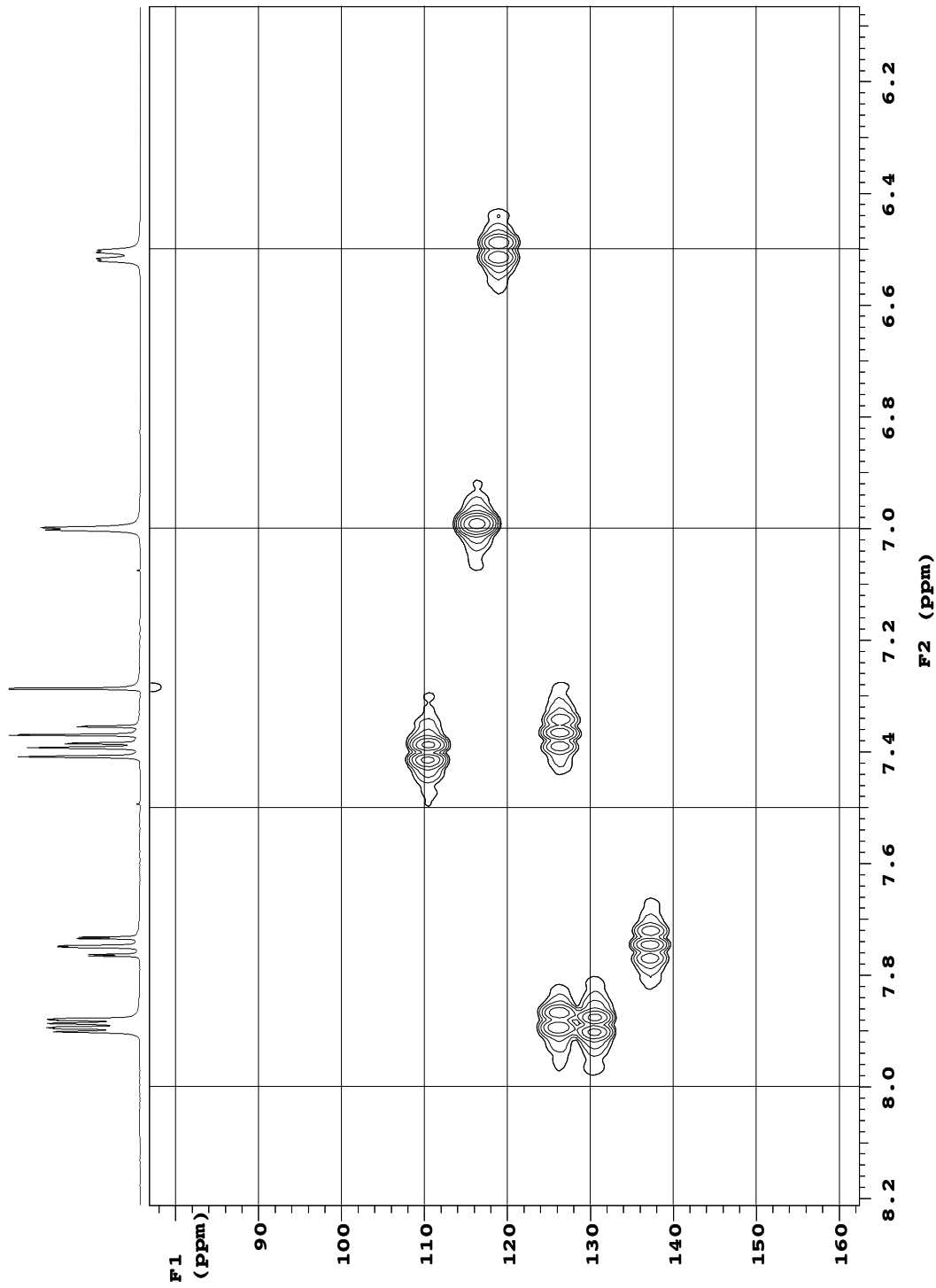

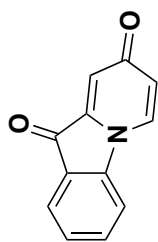

77

HMBC

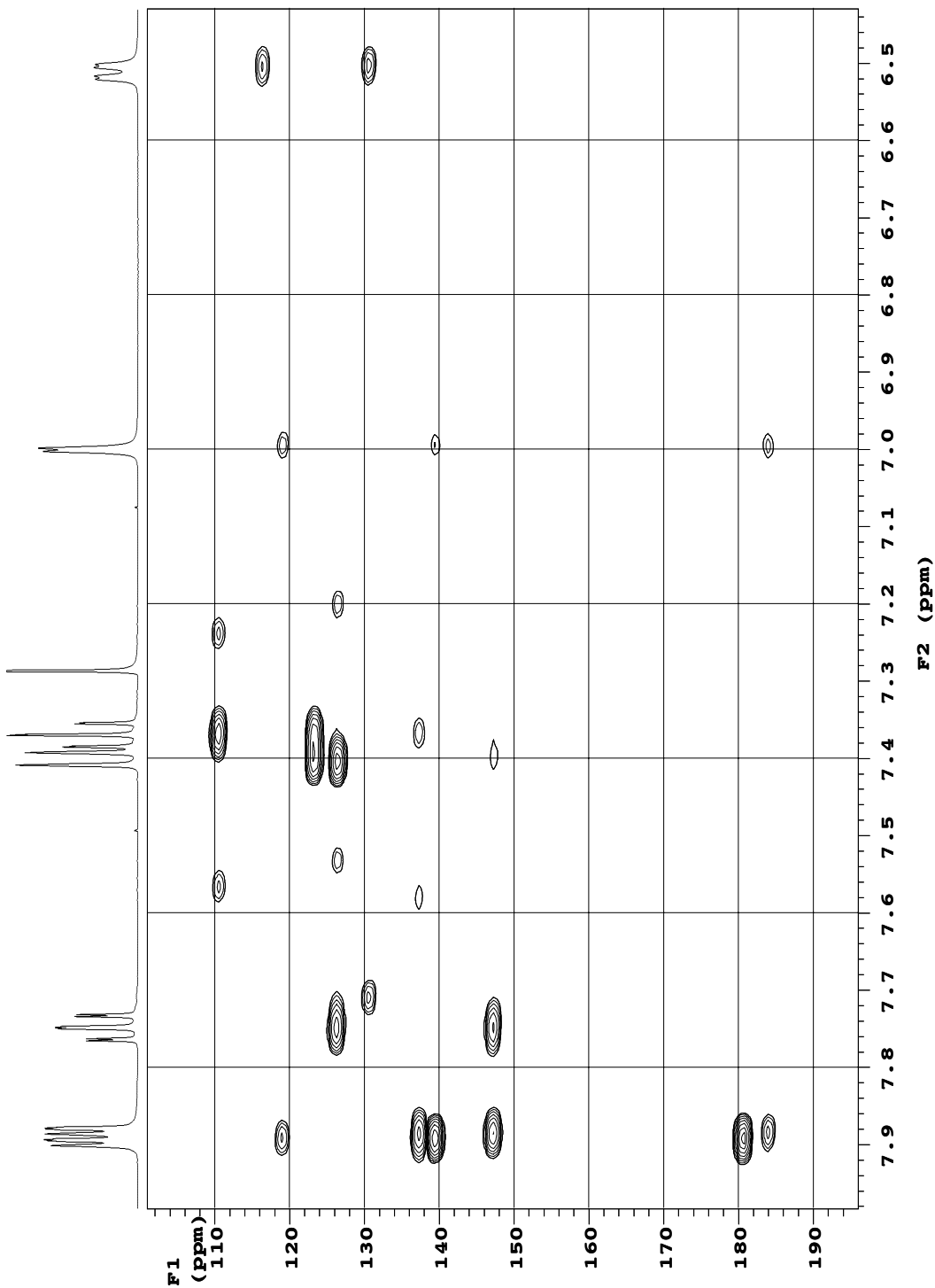

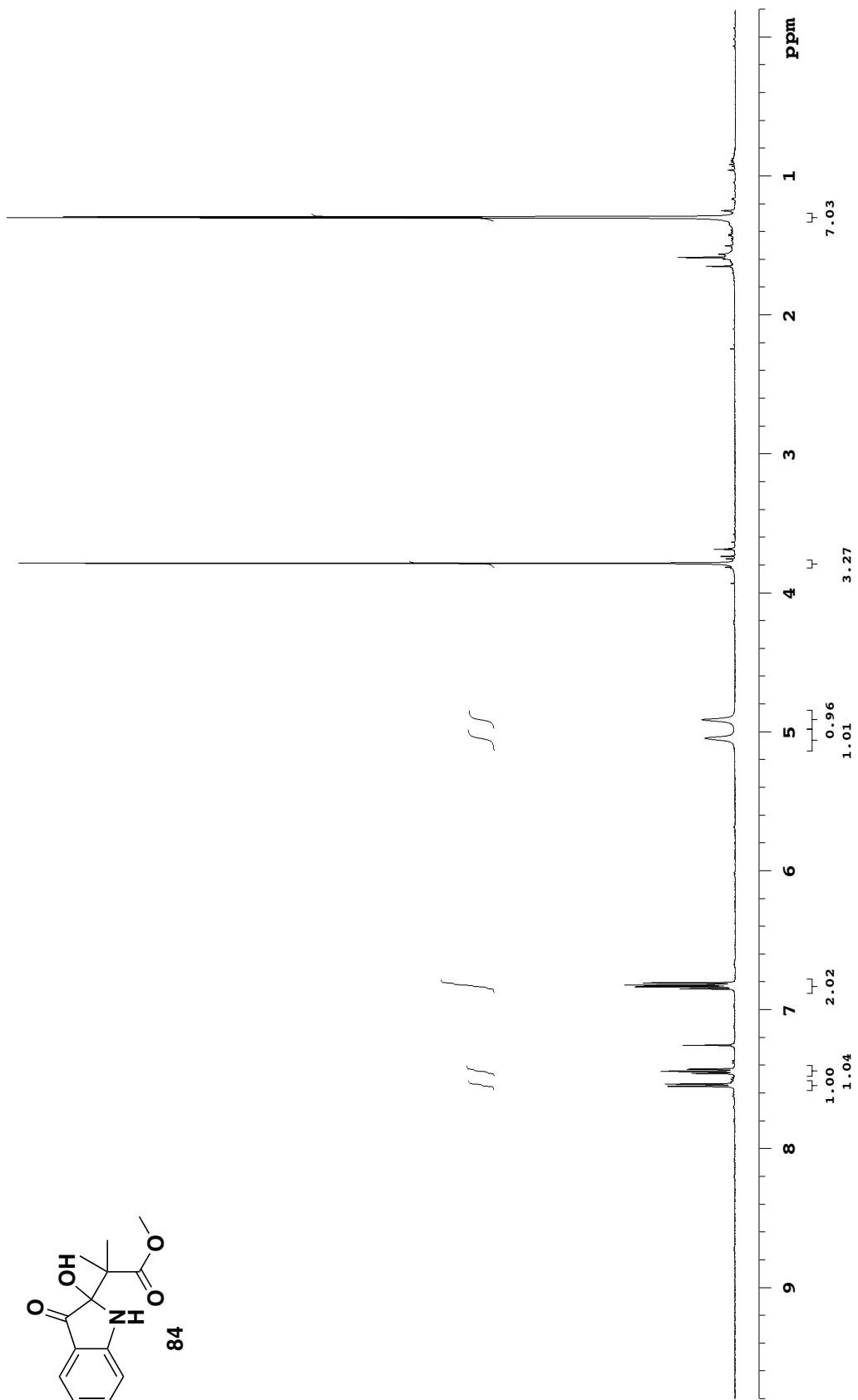
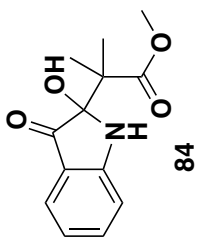

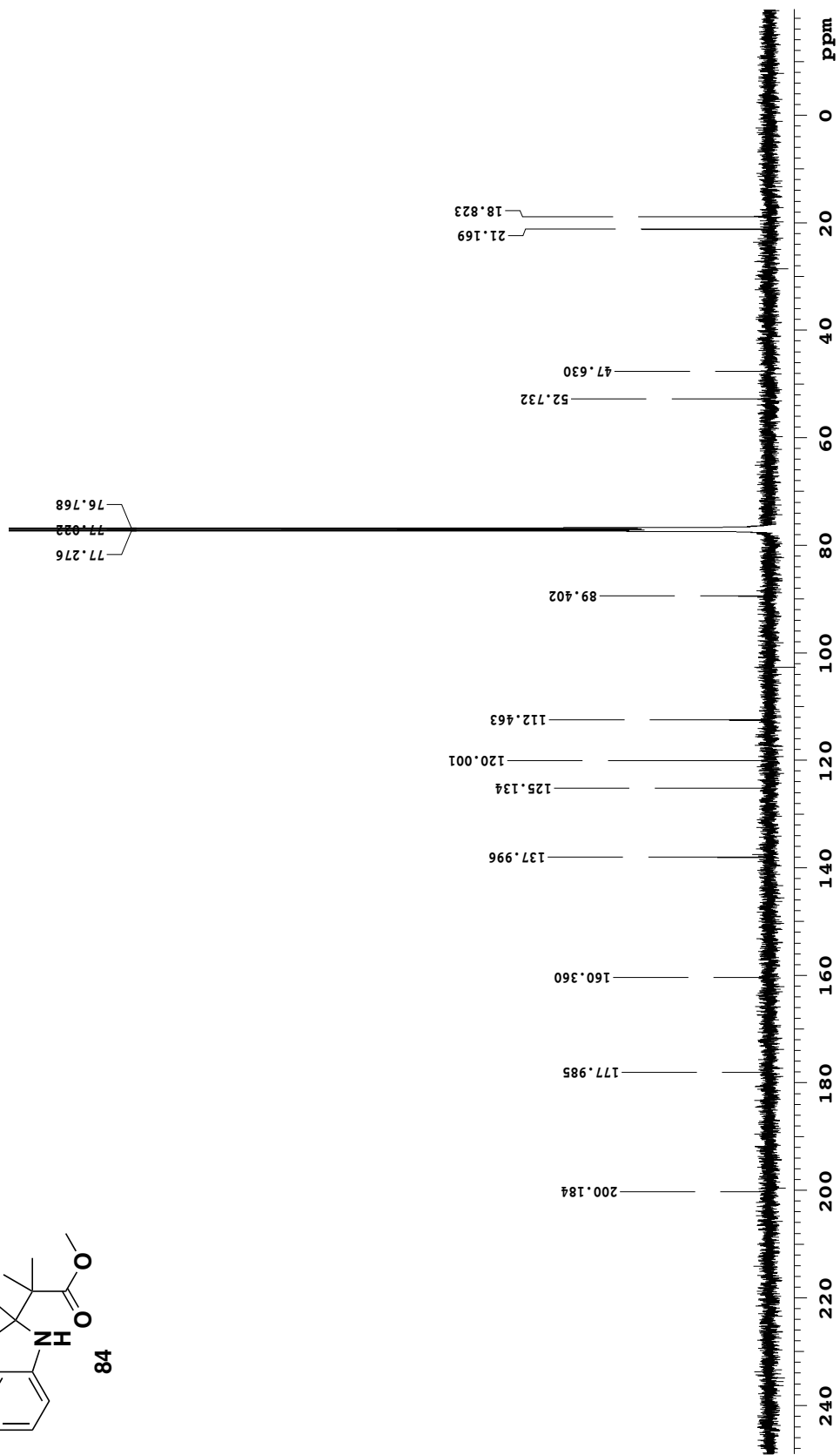
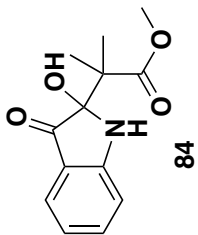

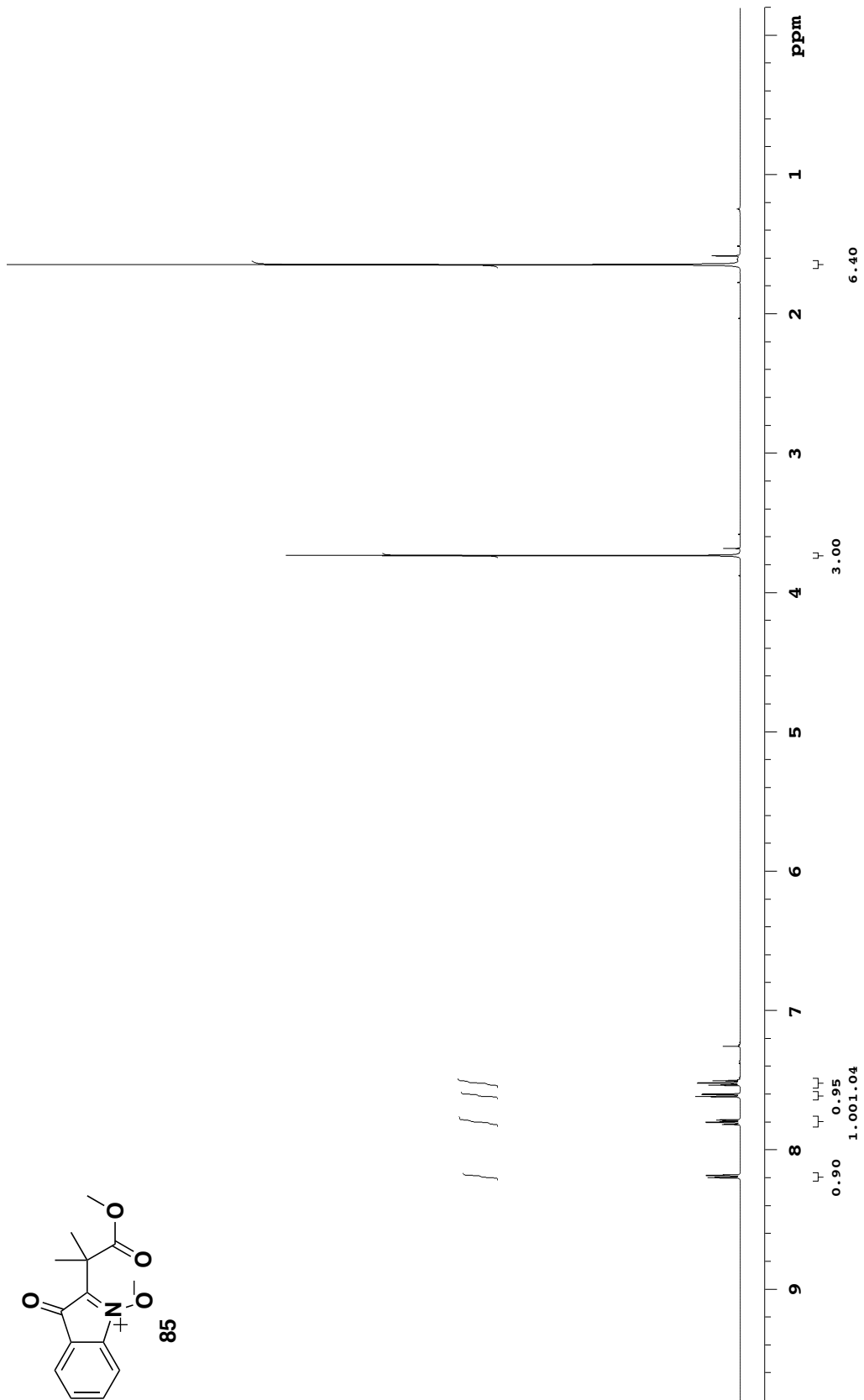
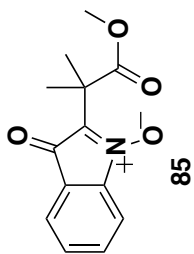

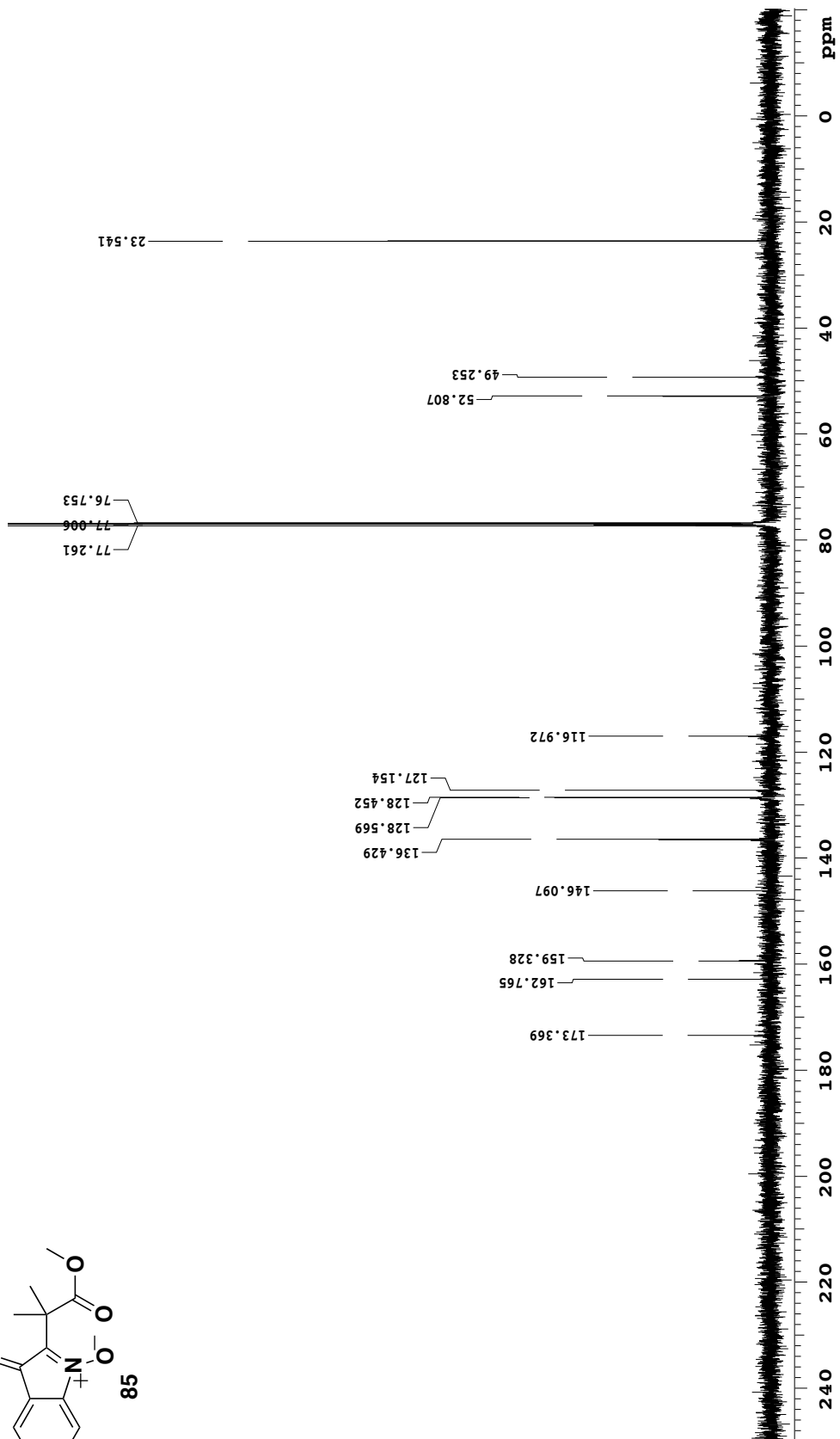
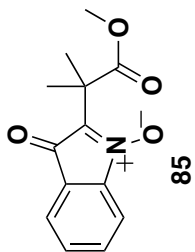

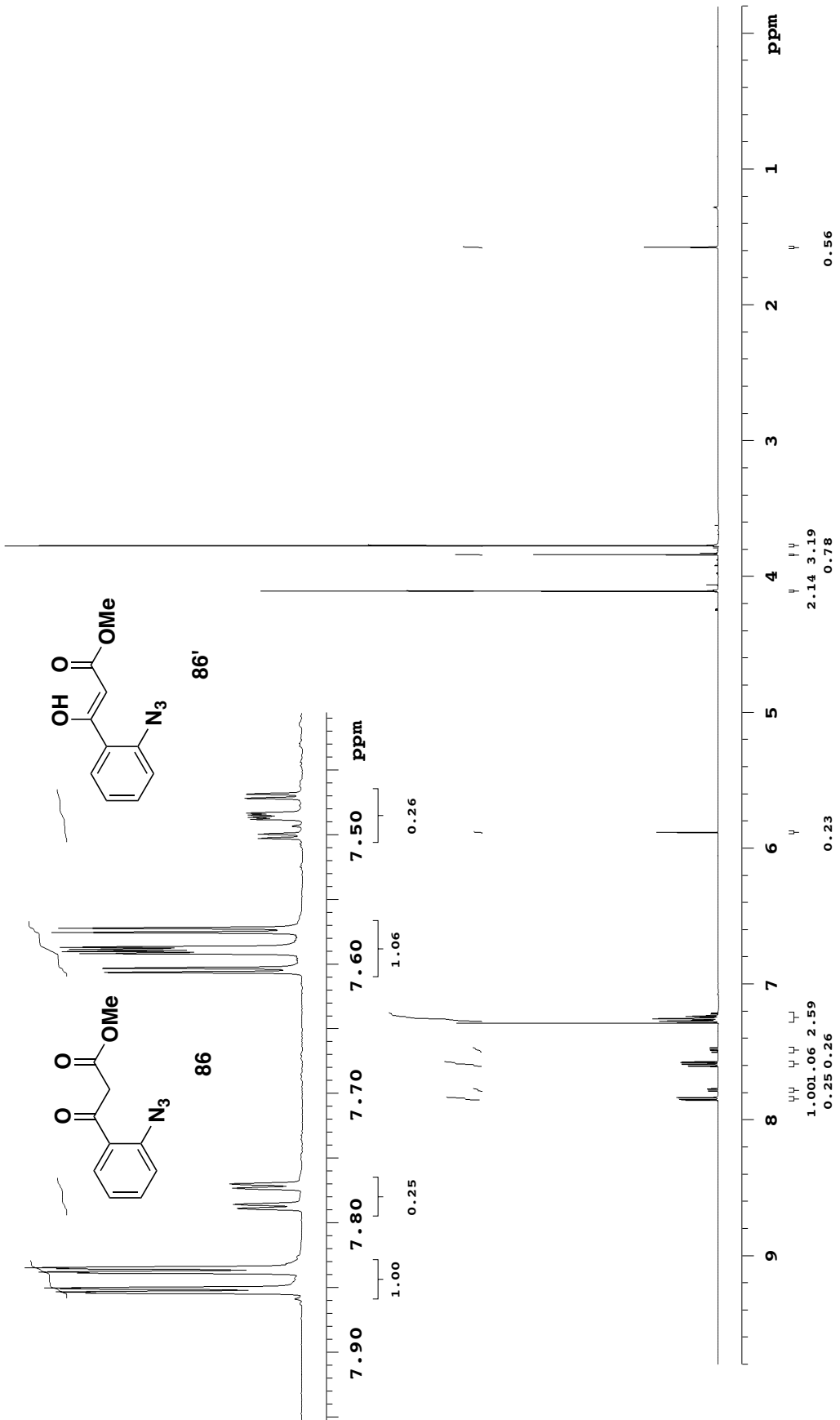

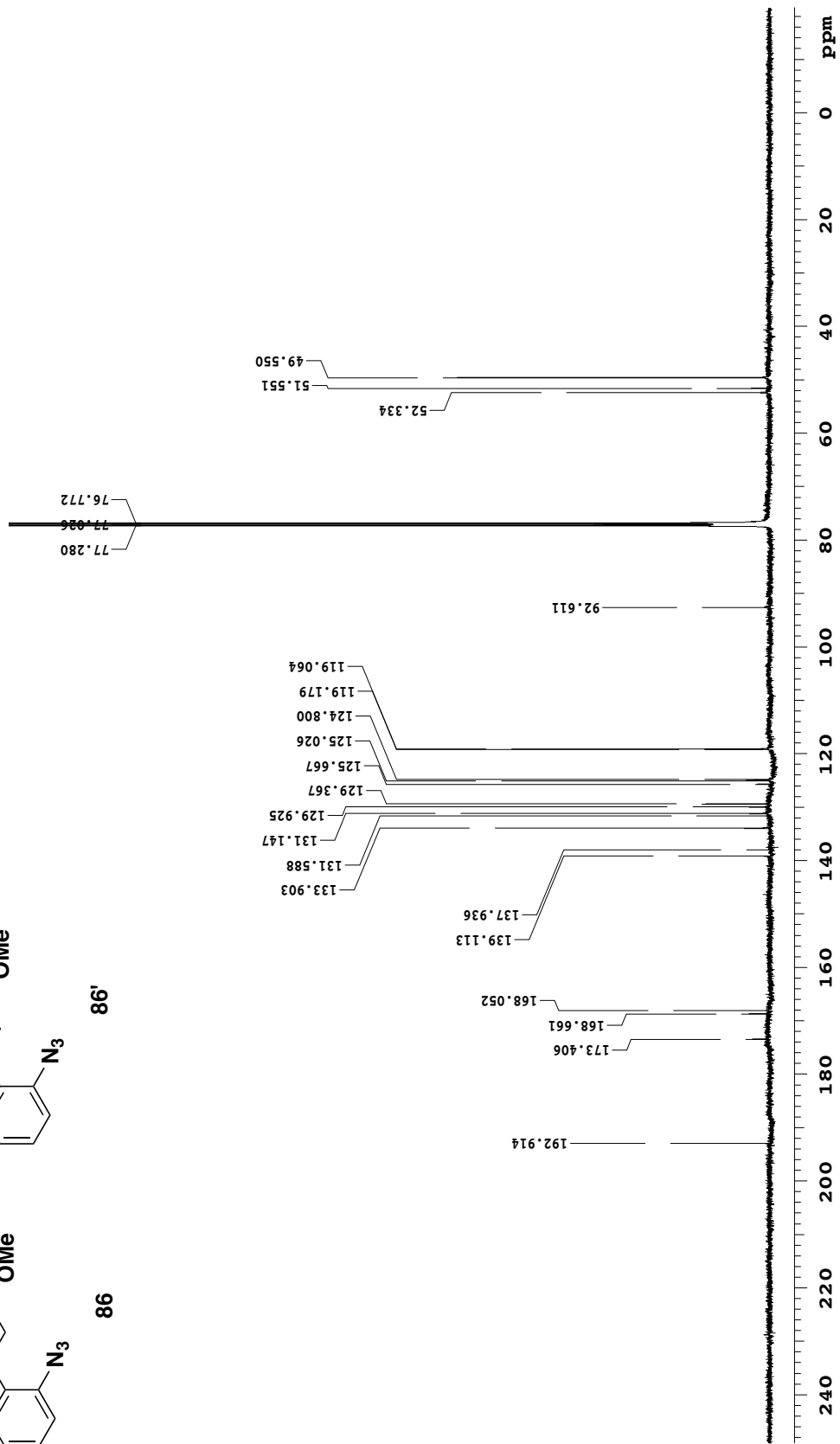
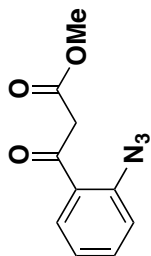
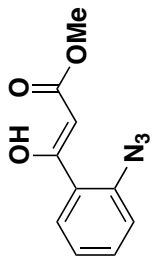

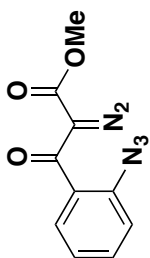

87

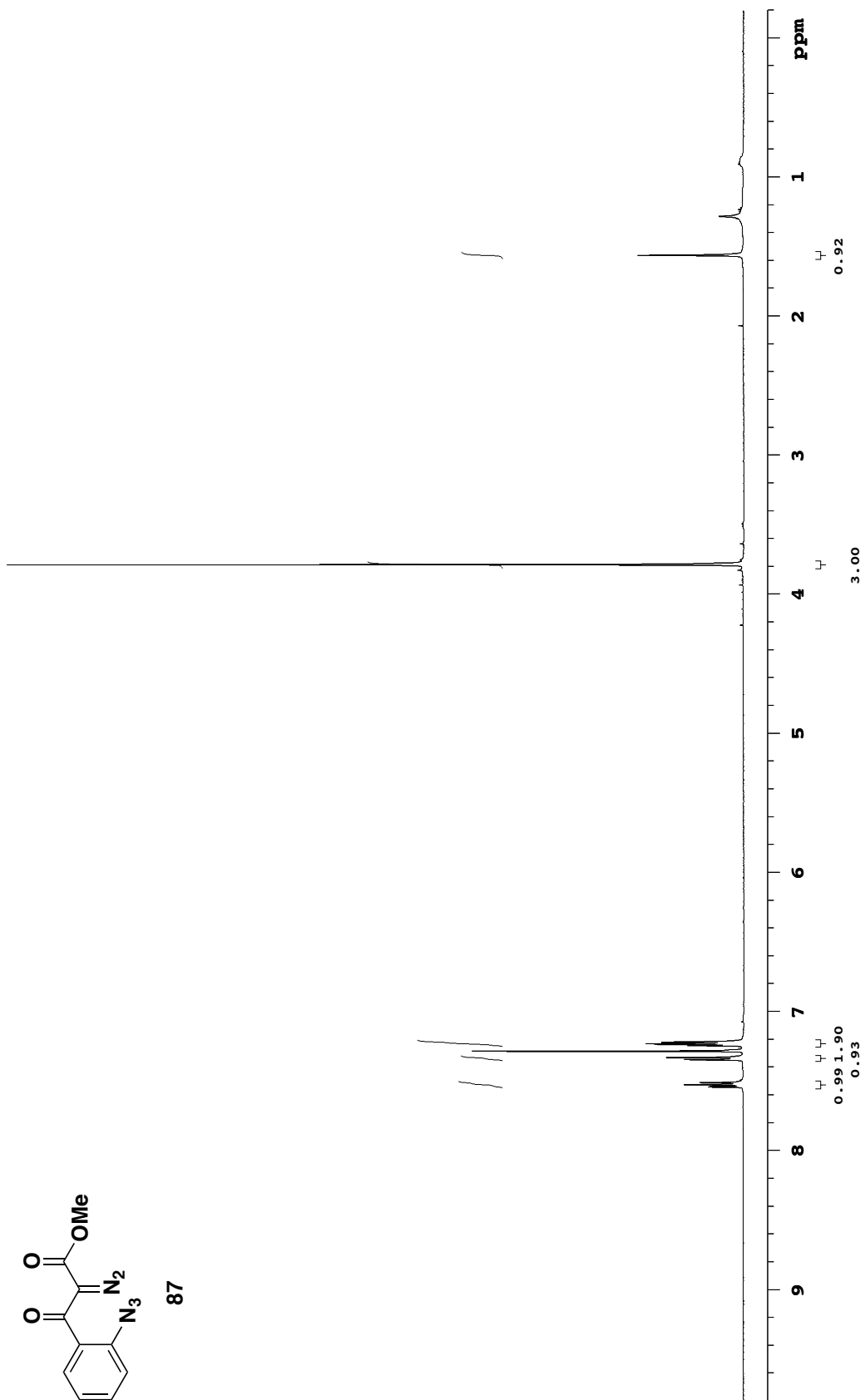

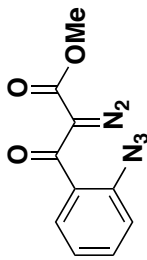

87

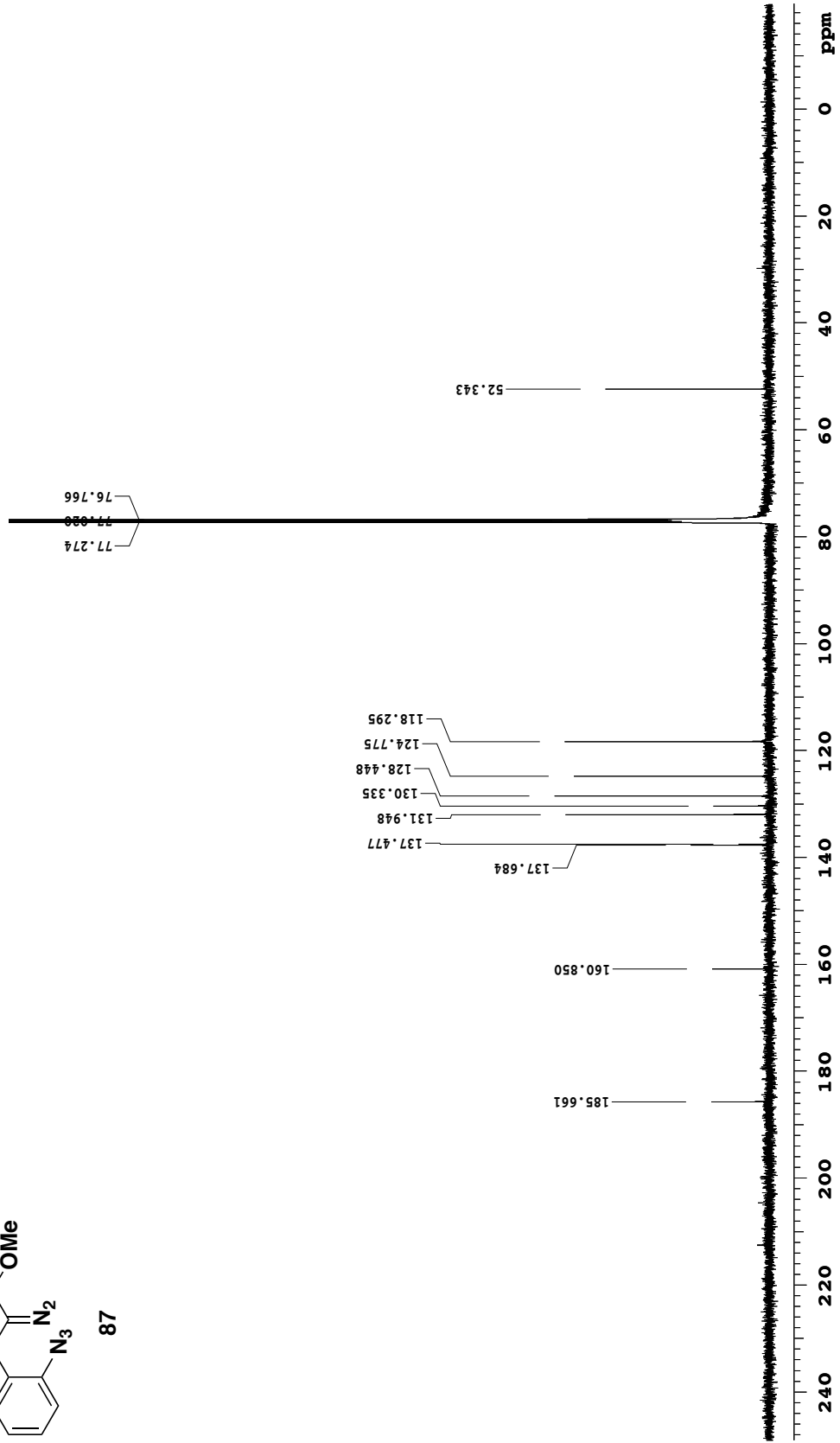

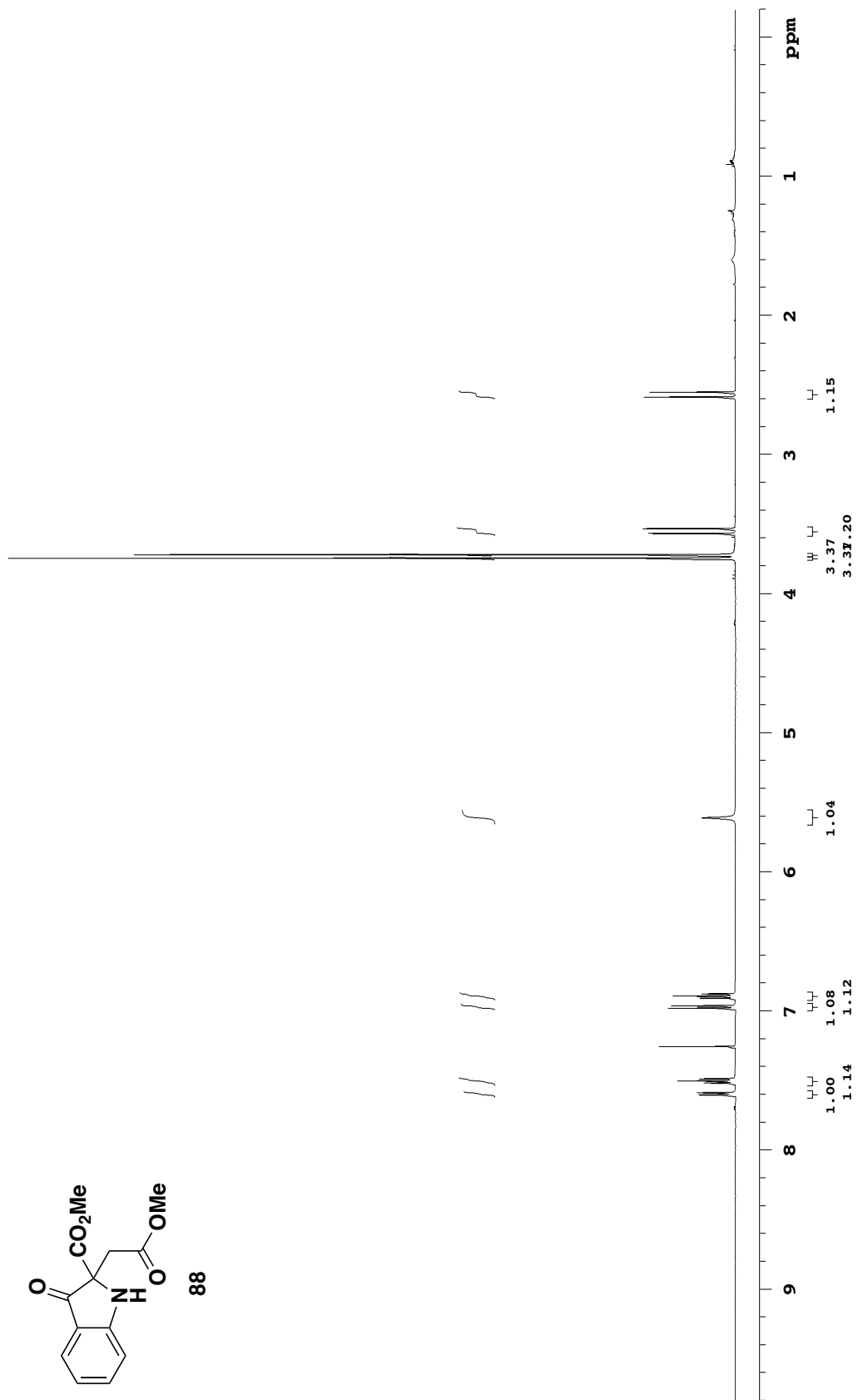
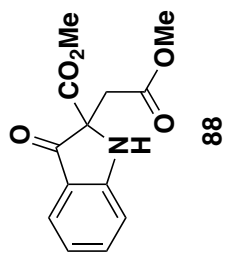

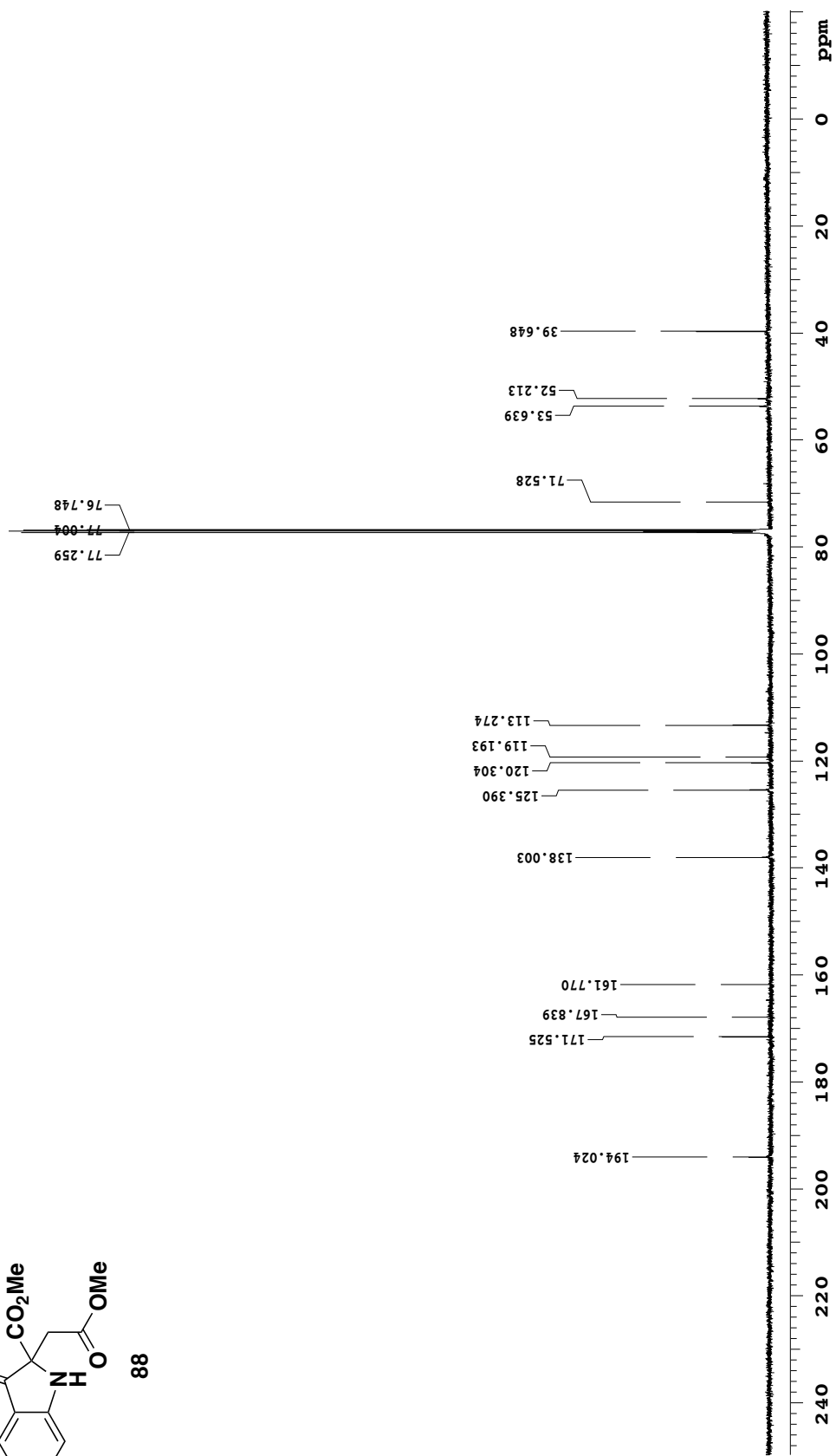
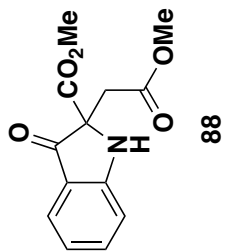

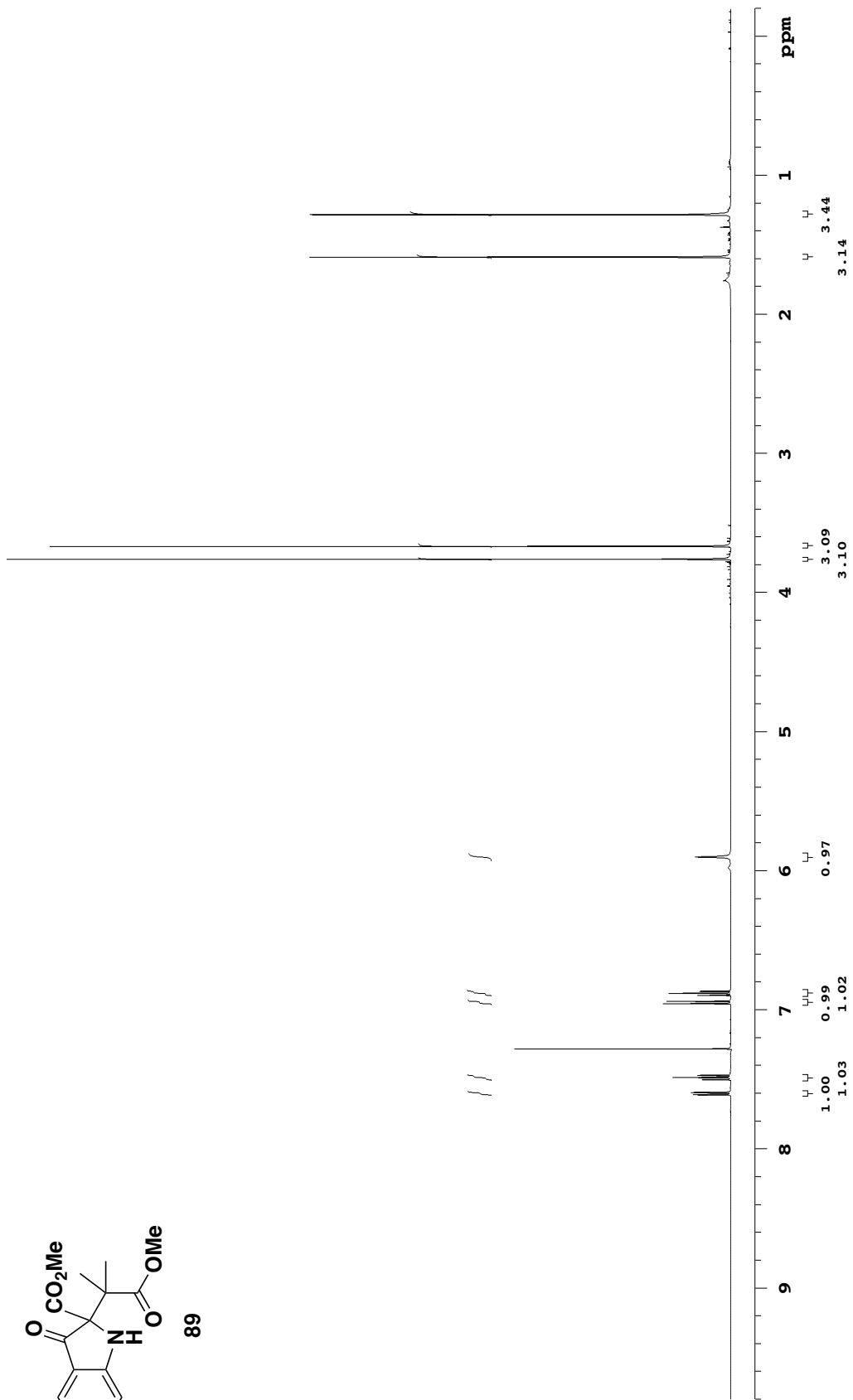
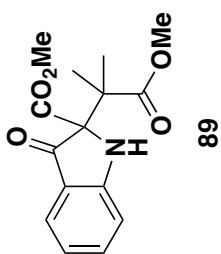

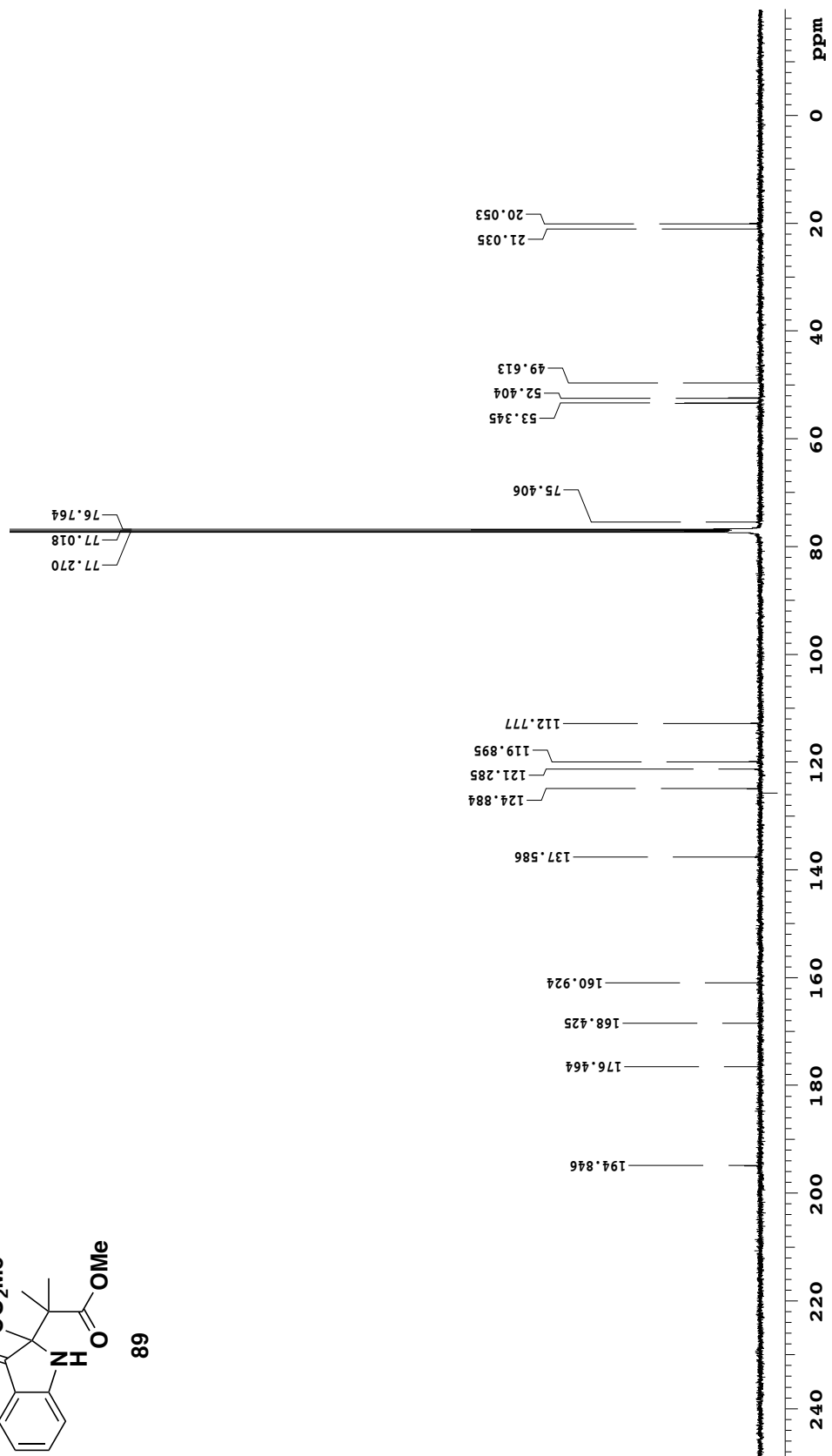
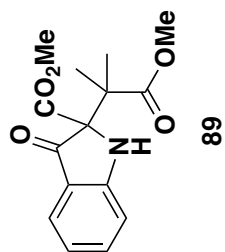

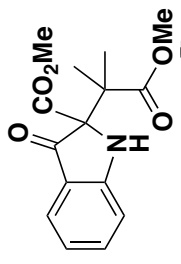

89
HMQC

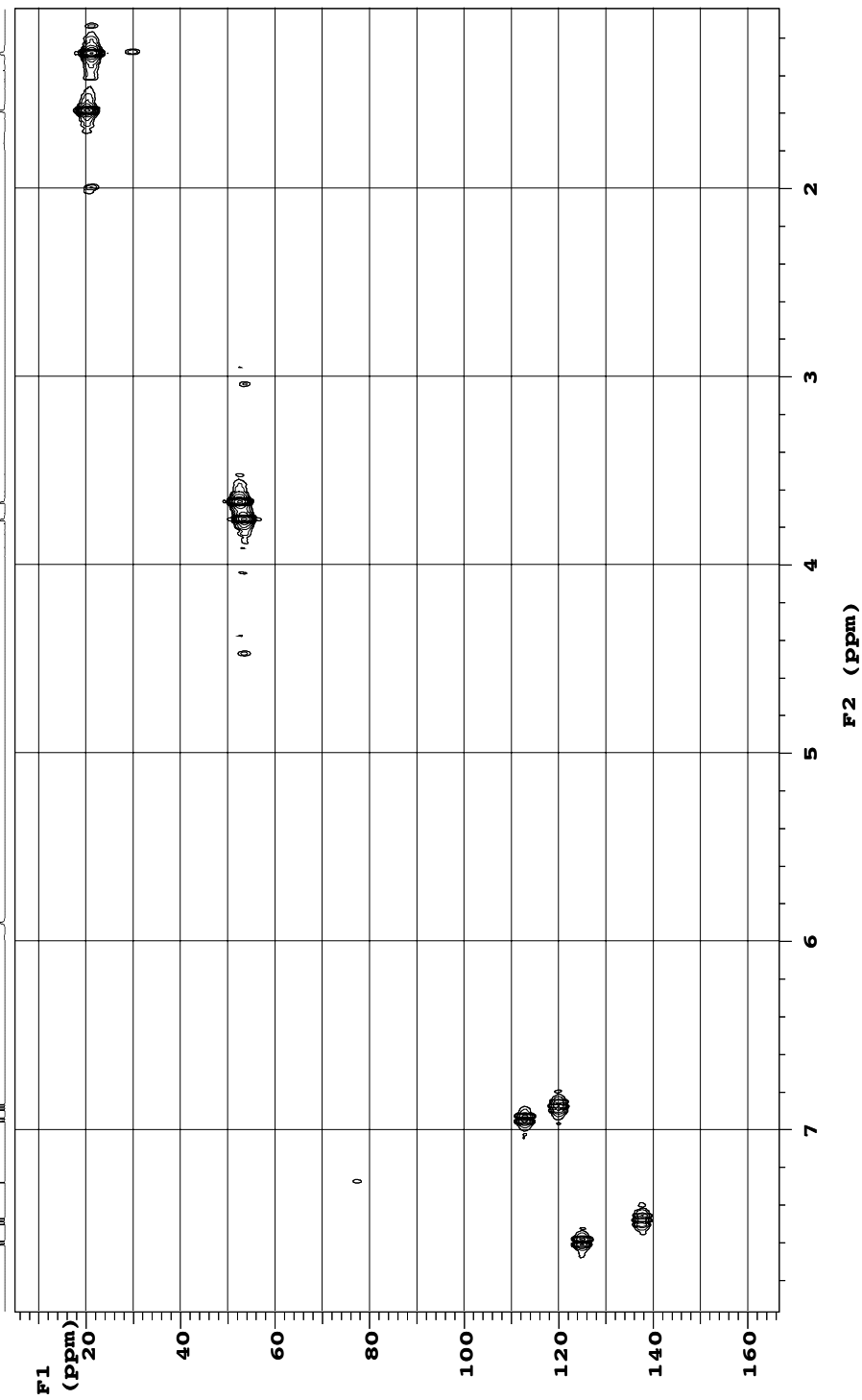

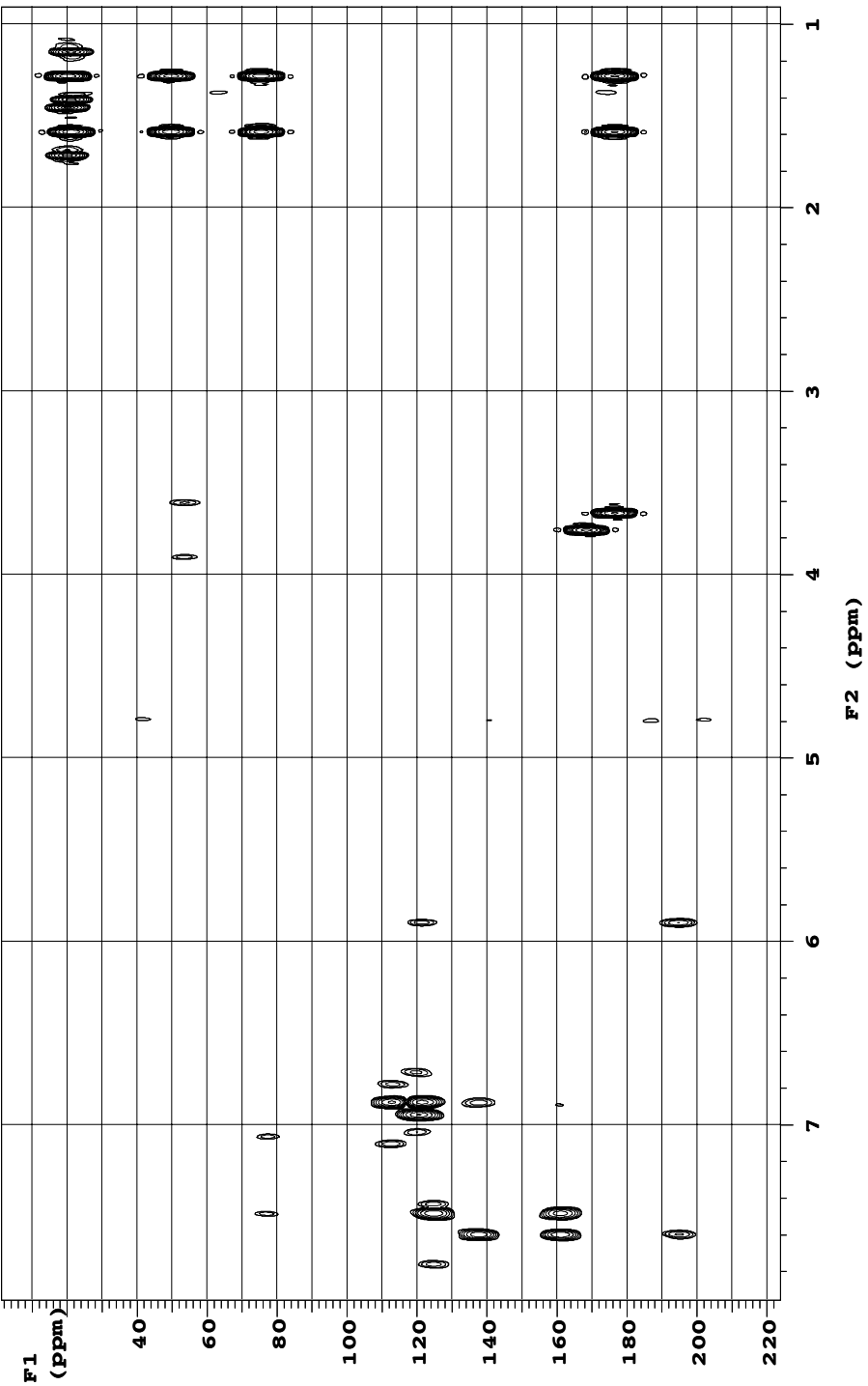
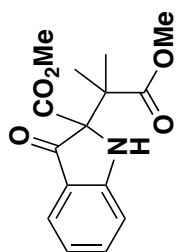

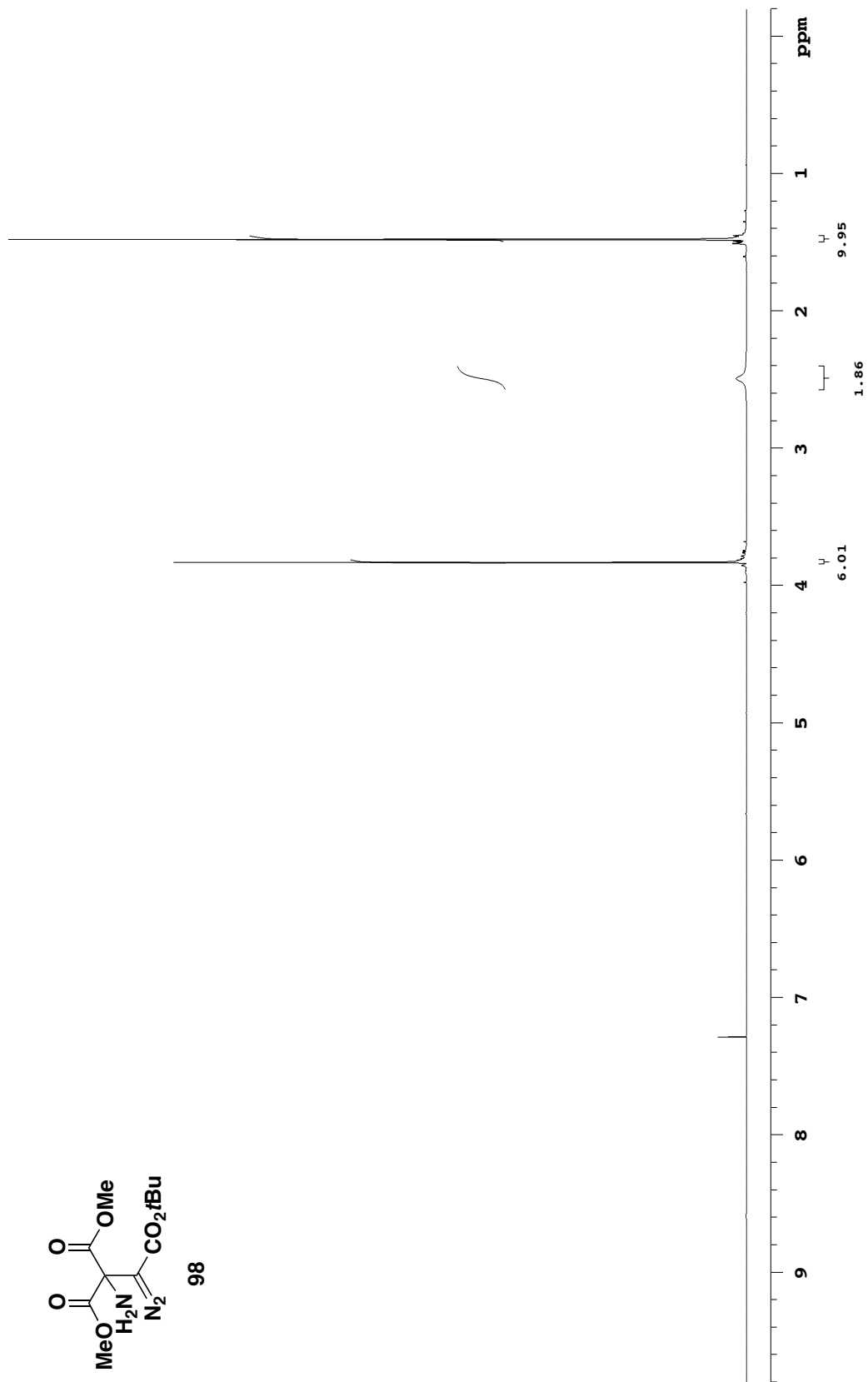
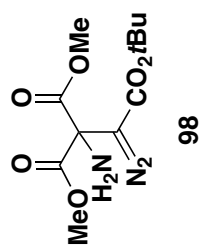

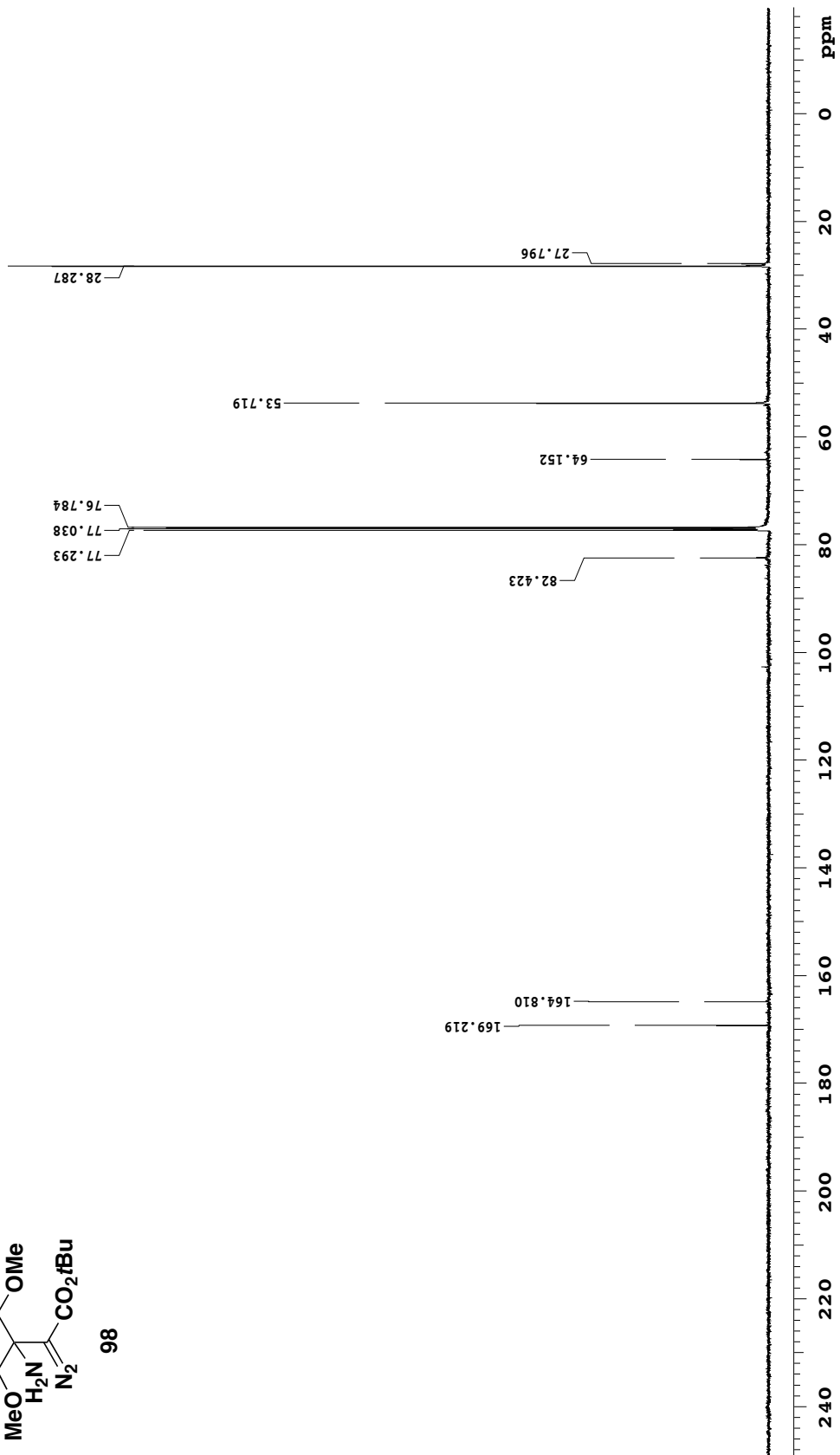
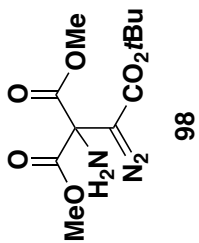

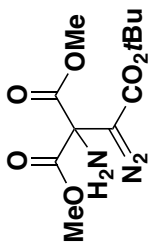

98
HMQC

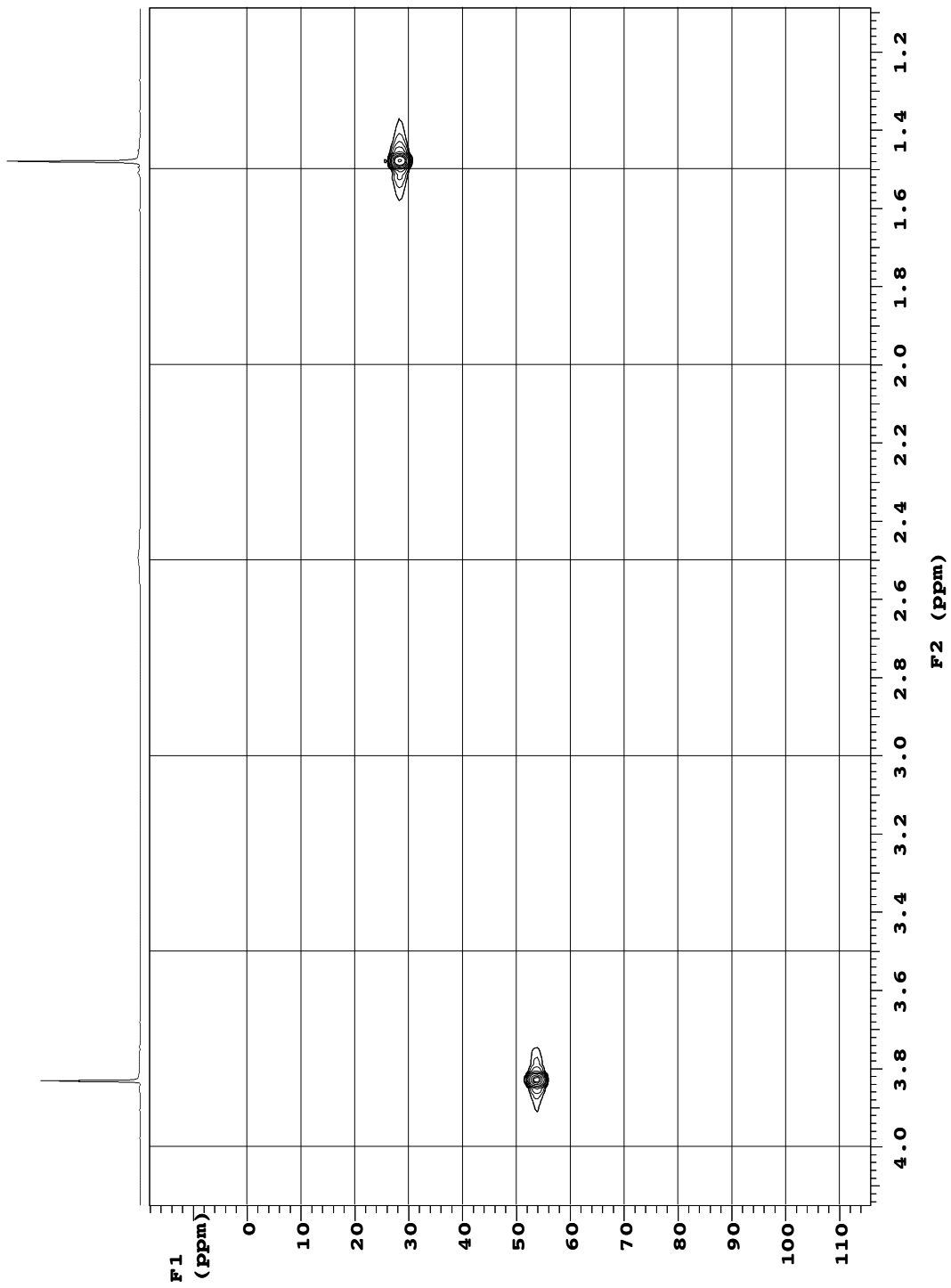

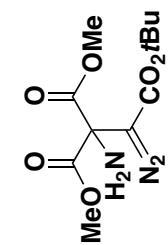

98

HMBC

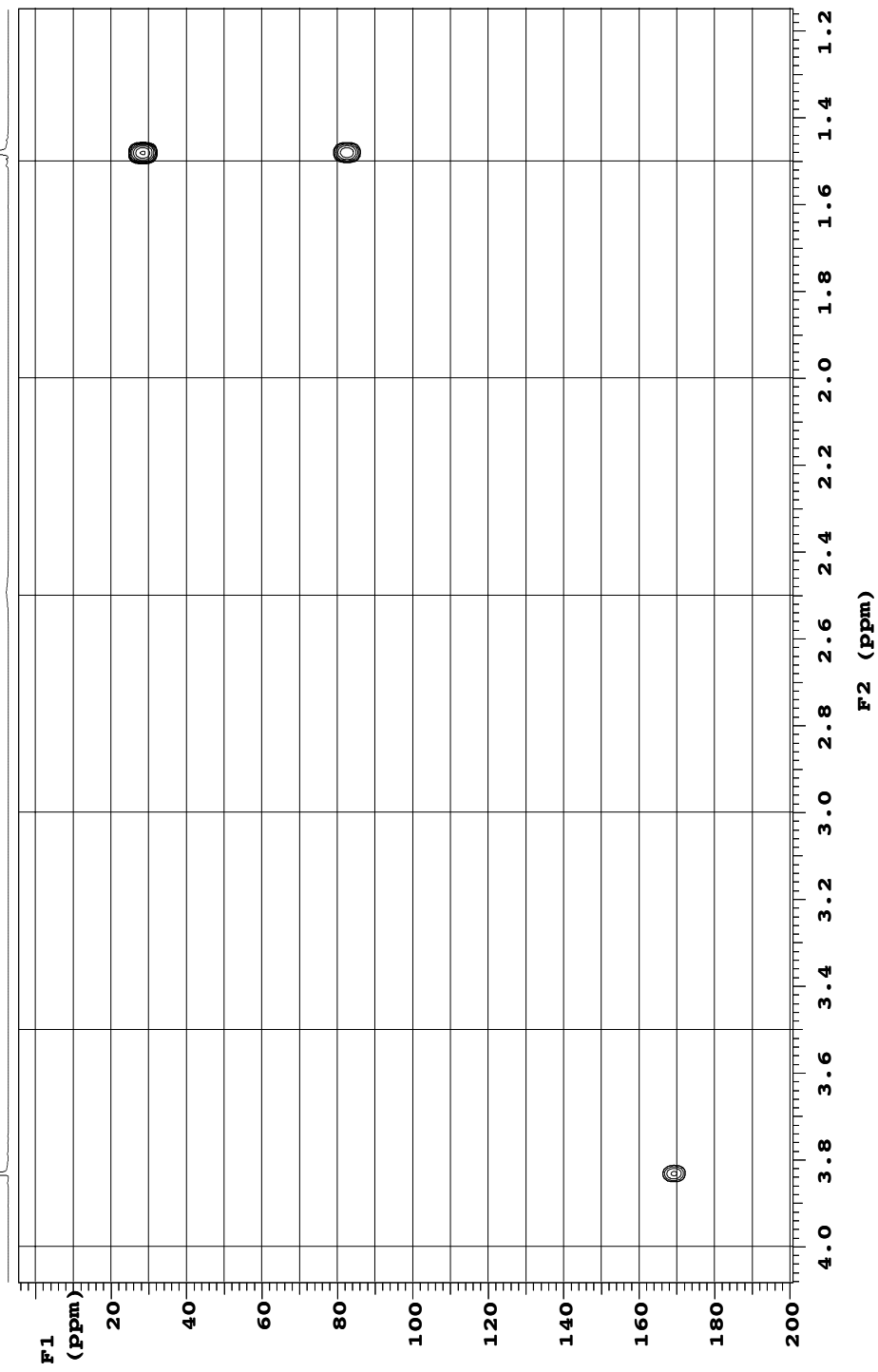

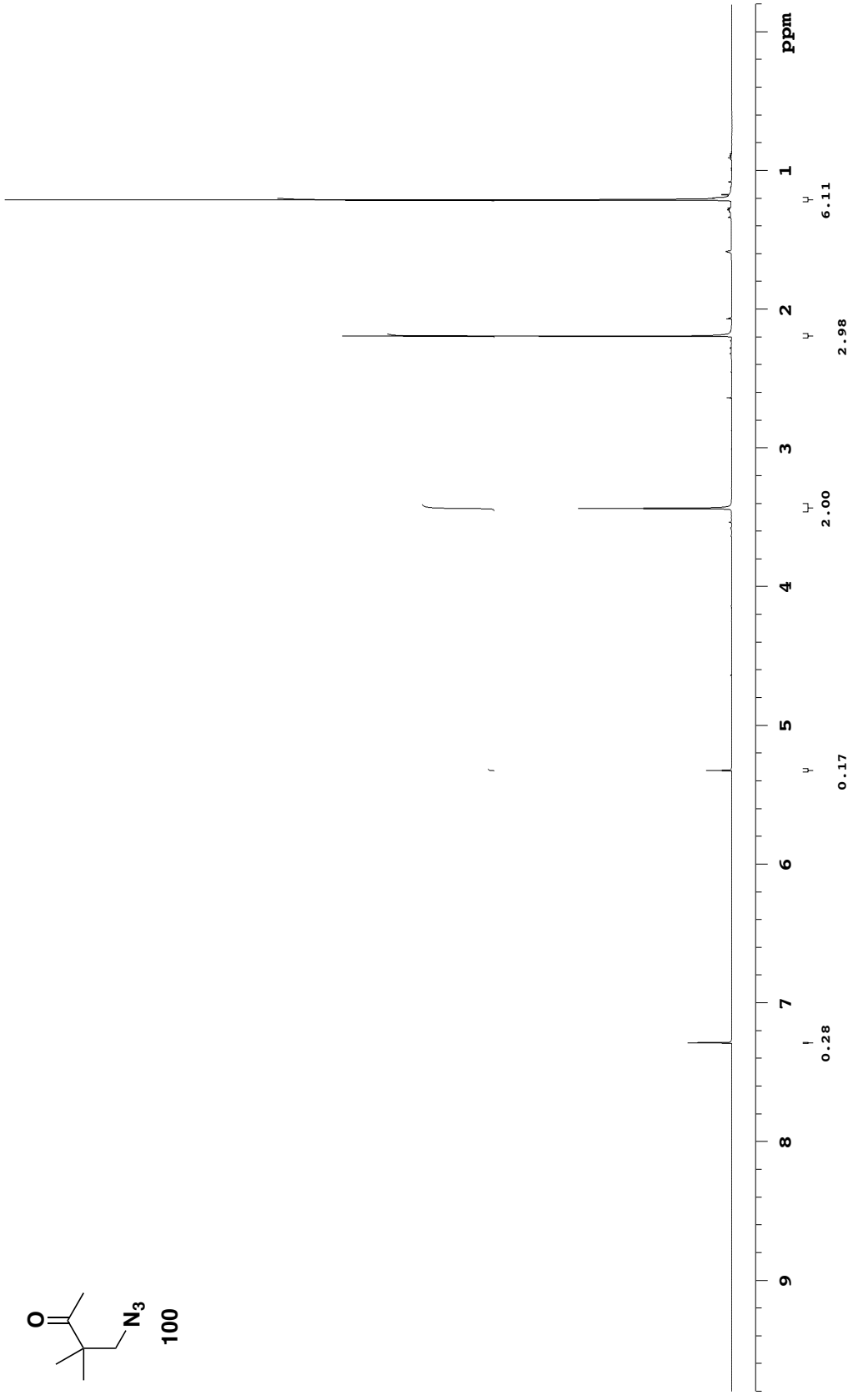
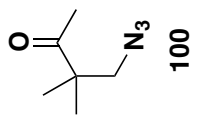

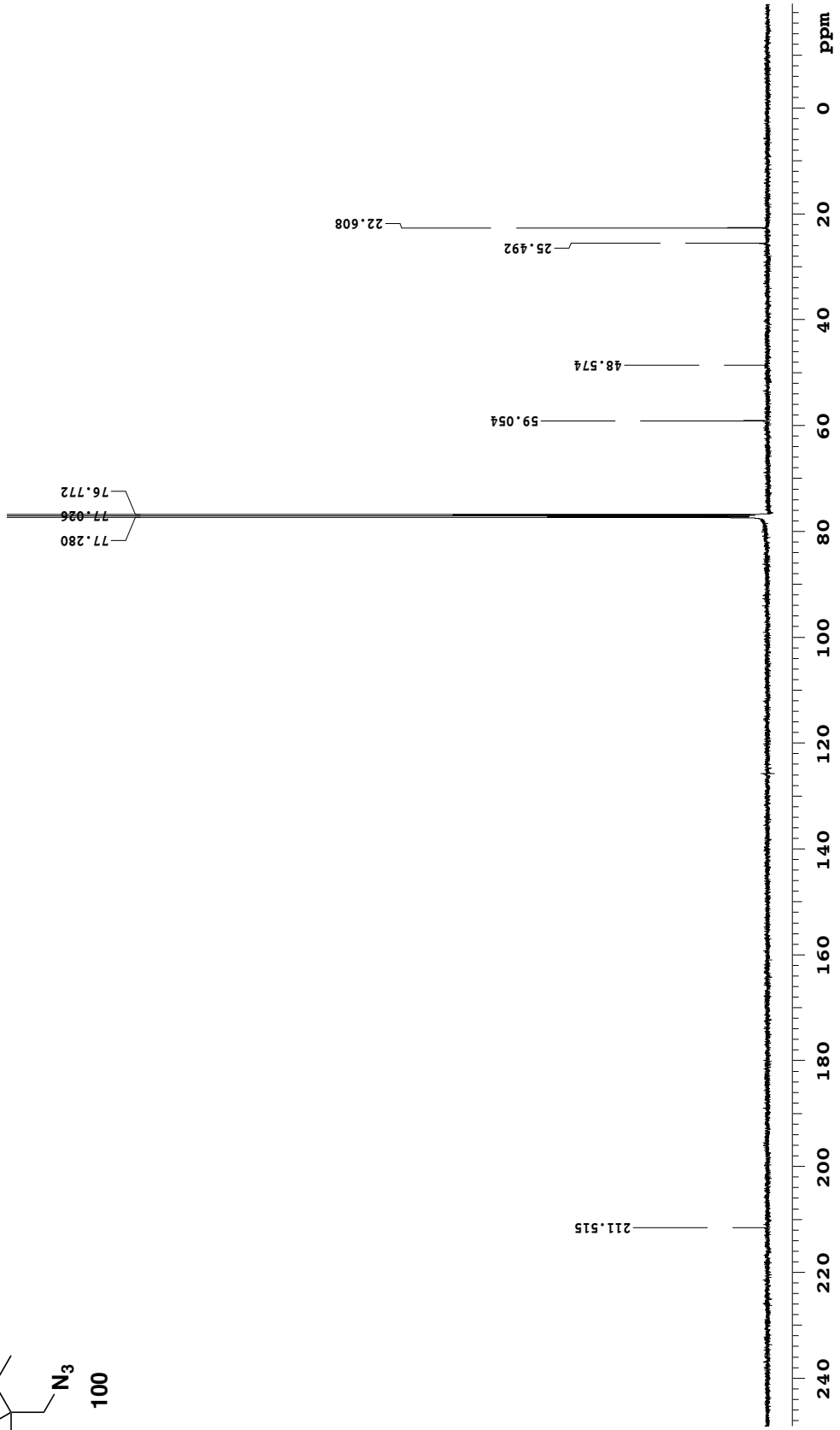
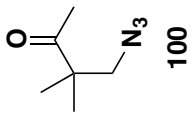

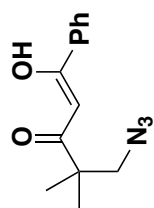

103

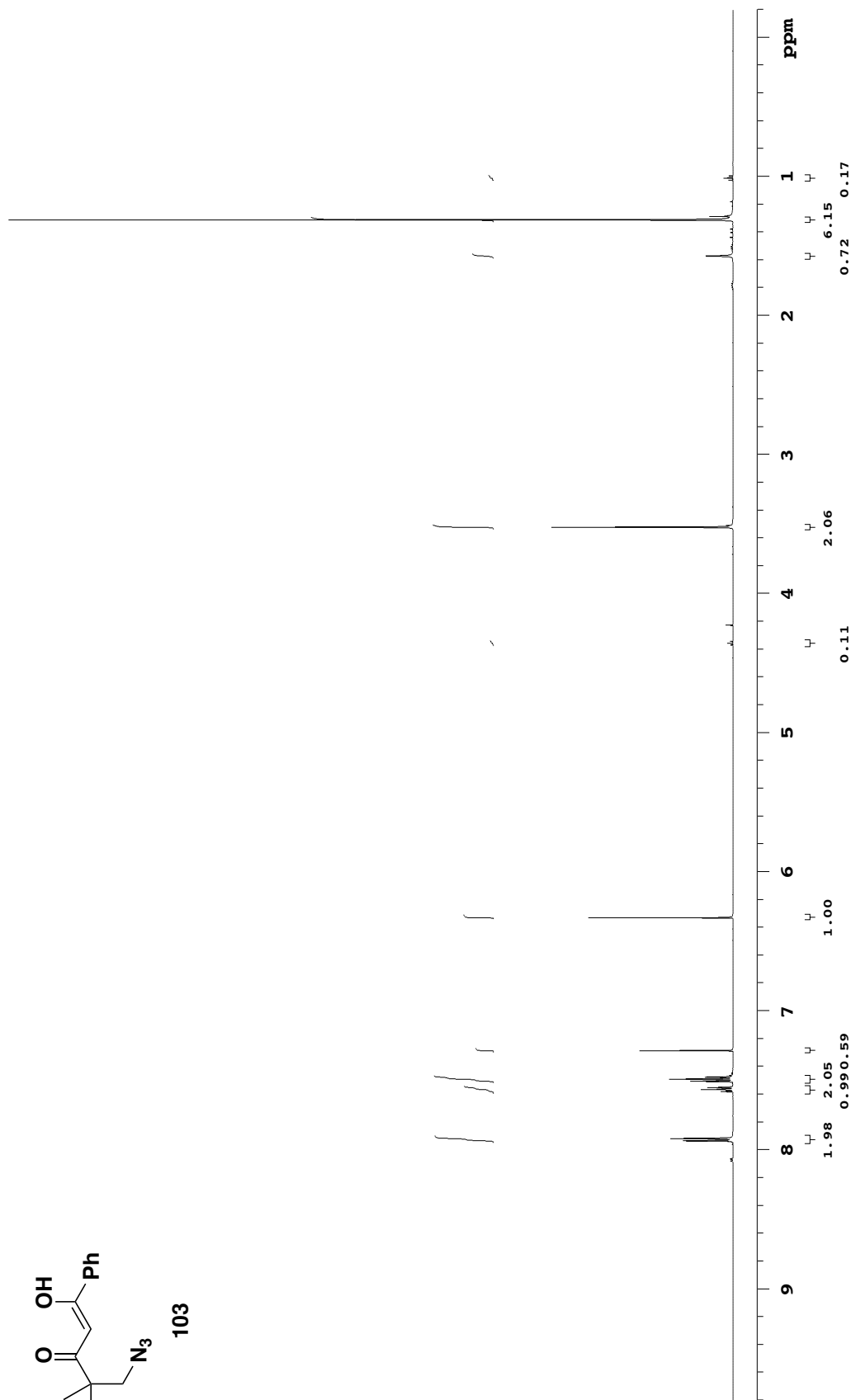

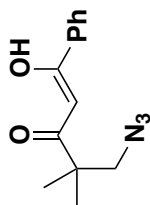

103

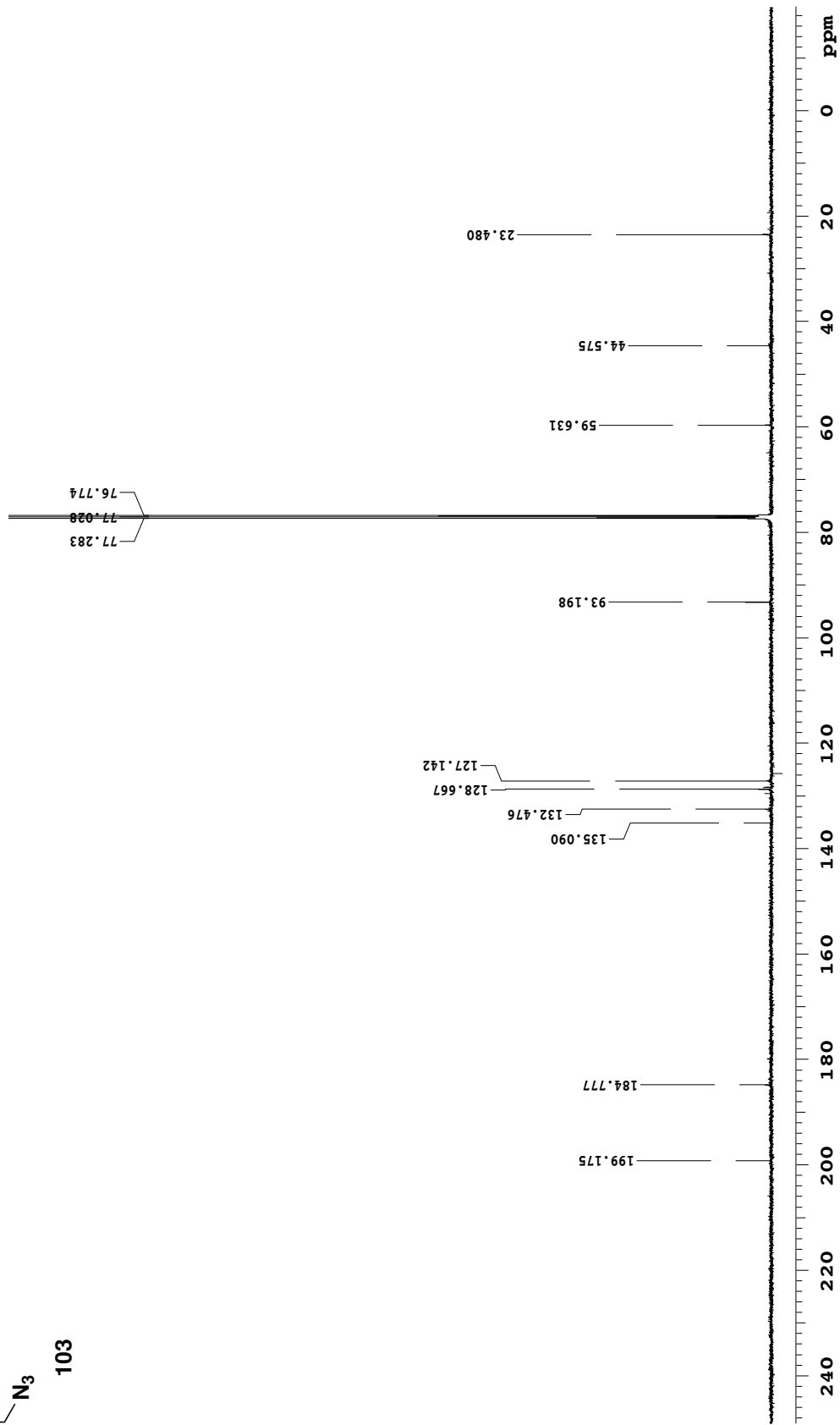

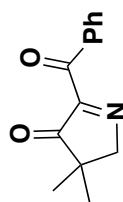

105

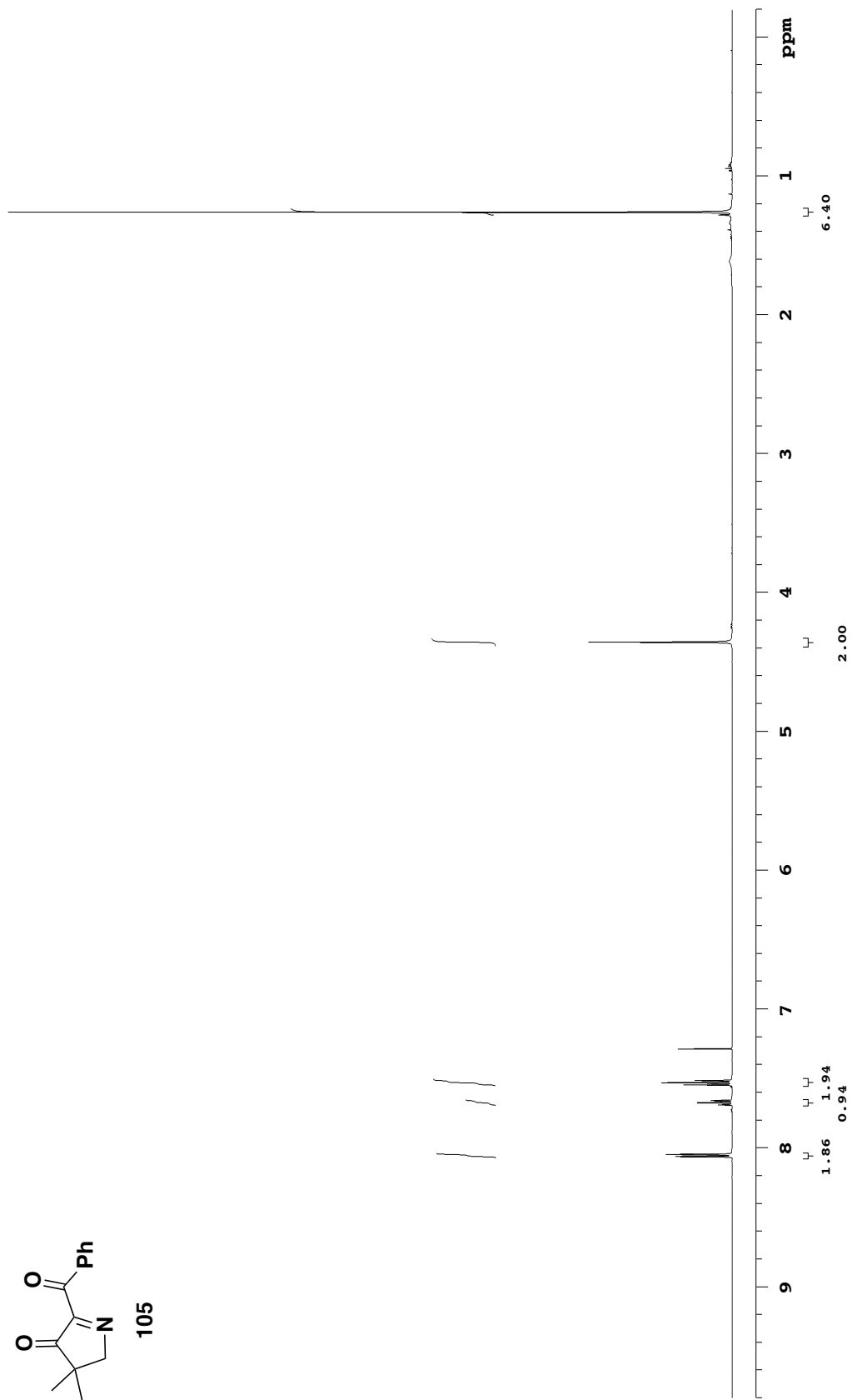

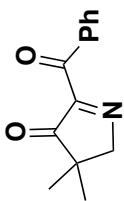
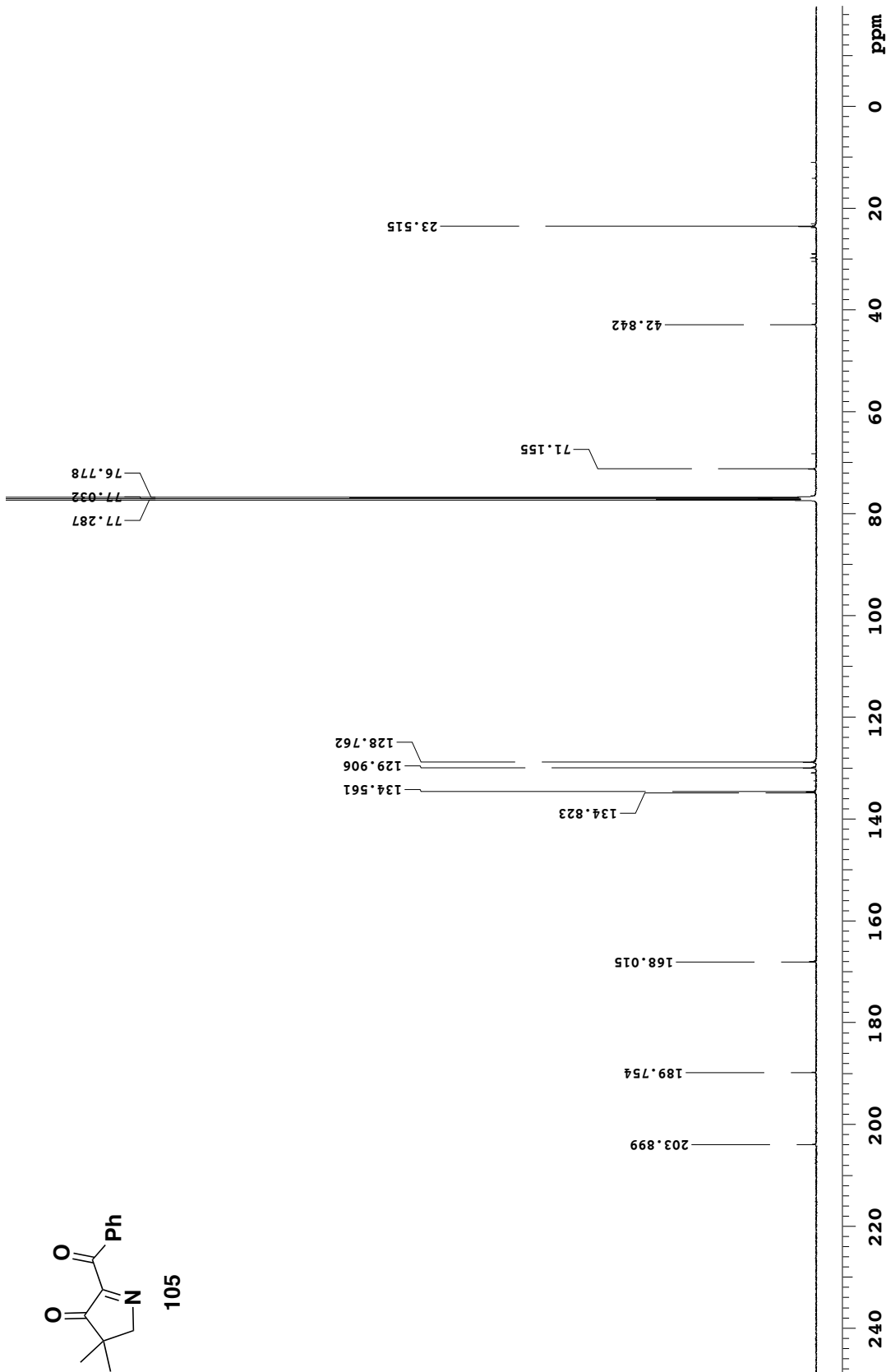

105

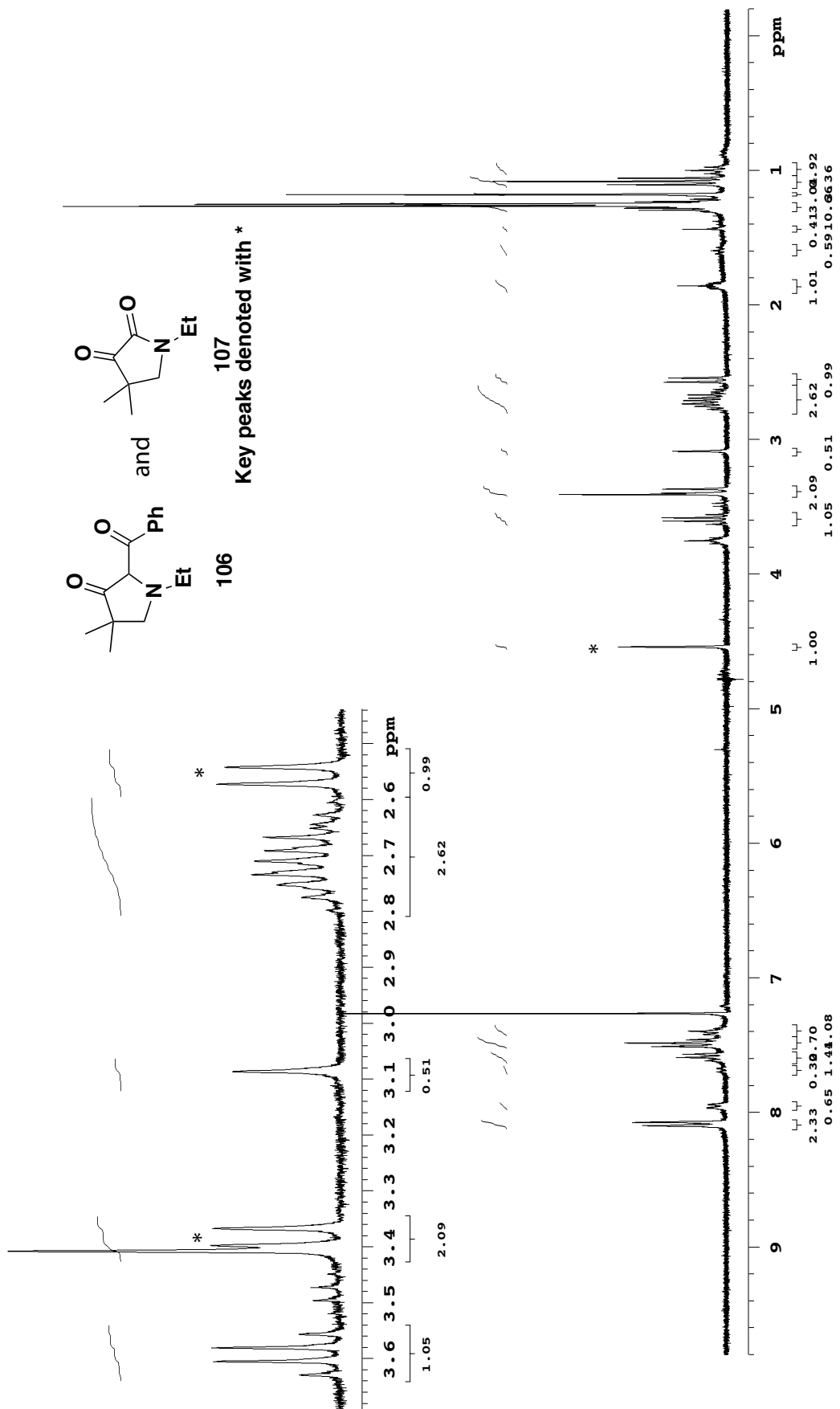

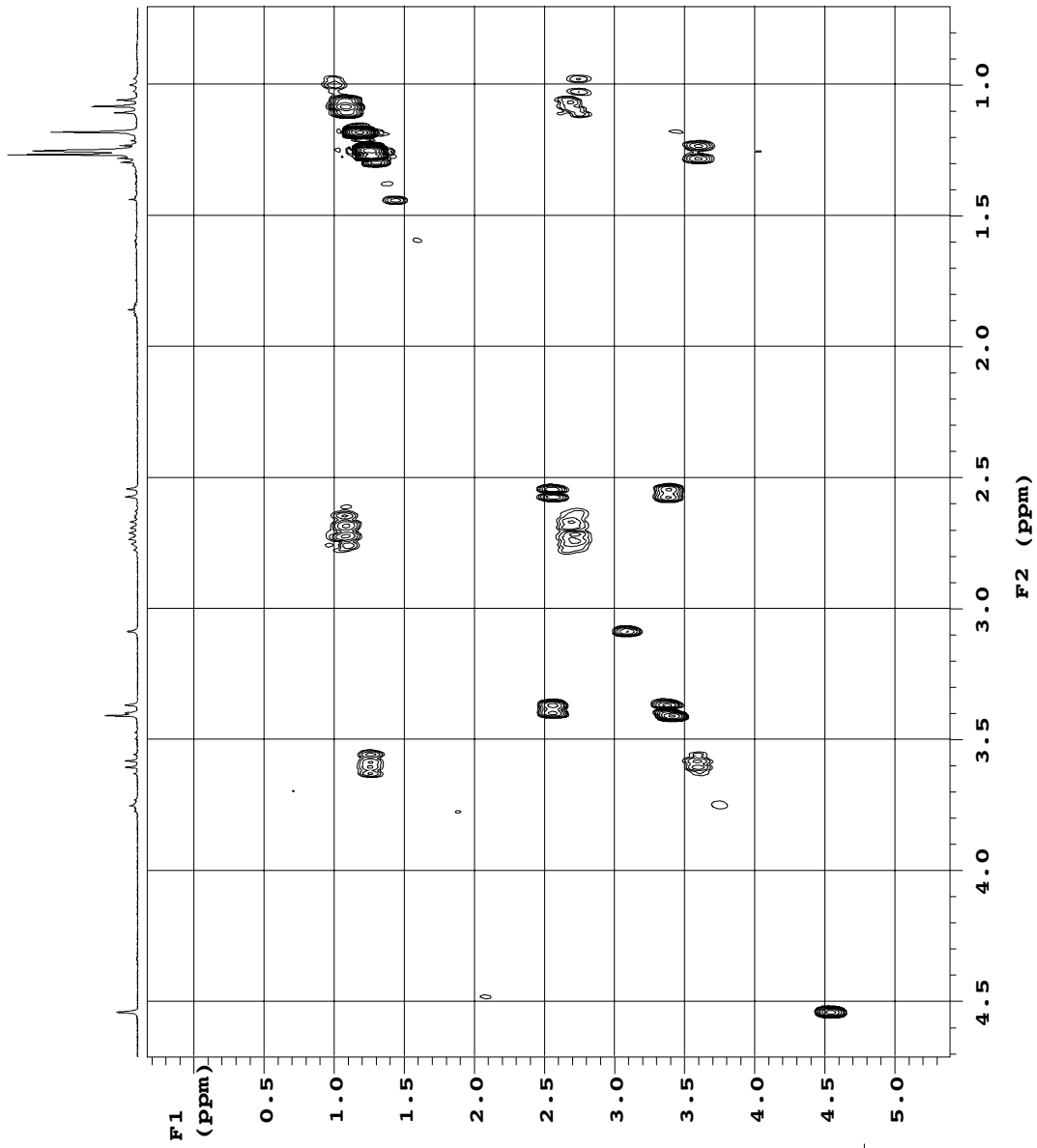
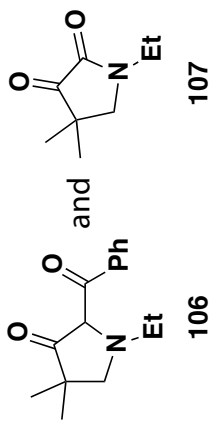

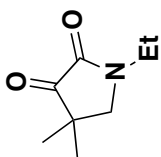

107

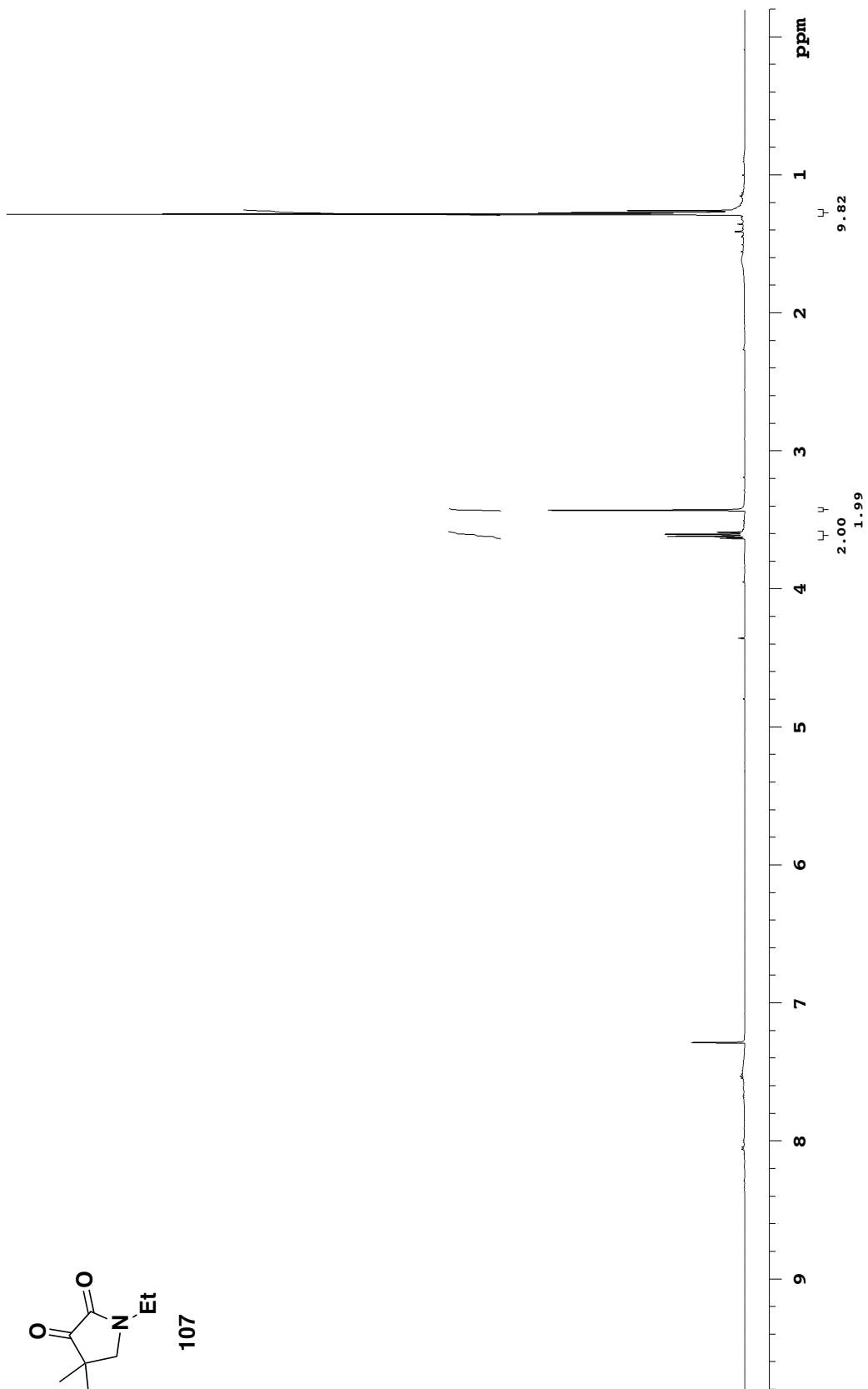

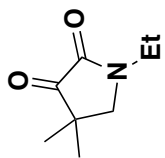

107

